

Propane Conversion Kit Instructions

For G124X II/DI – Model Boilers

This kit and instructions are for converting the G124 X II/DI – Model Boilers from Natural Gas to Propane.

REQUIRED INPUT RATES

G 124 X-18 74, 000 BTU/HR	G 124 X-25 103, 000 BTU/HR	G 124 X-32 132, 500 BTU/HR
------------------------------	-------------------------------	-------------------------------

WARNING

This conversion kit shall be installed by a qualified service agency in accordance with the manufacturer's instructions and all applicable codes and requirements of the authority having jurisdiction. If the information in these instructions is not followed exactly, a fire, explosion or production of carbon monoxide may result causing property damage, personal injury or loss of life. The qualified service agency performing this work assumes responsibility for the proper conversion of this appliance with this kit.

CAUTION: The gas supply shall be shut off prior to disconnecting the electrical power, before proceeding with the conversion.

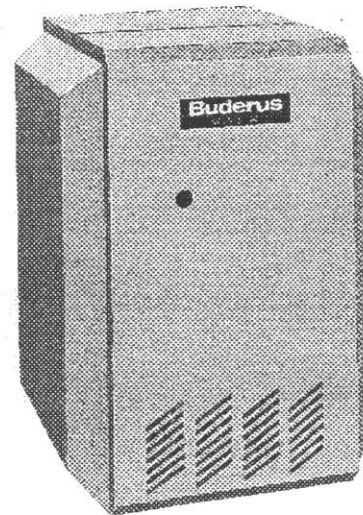

Notice: This manual must be retained for future reference!

Parts List for converting the boilers to propane

This kit contains the following parts.

- Honeywell gas valve conversion kit # 393 691 which includes:
 - black capscrew
 - pressure regulator adjusting screw
 - red spring
 - yellow label for gas control
- Pilot orifice BBR 12
- Main gas burner orifices and gaskets
- Label to be filled out and affixed to the appliance
- Instructions

TO CONVERT THE BOILER TO PROPANE, THE FOLLOWING INSTRUCTIONS SHALL BE ADHERED TO.

1. If the boiler has been in operation, shut off the main gas valve. If the boiler has not been placed into service, go to step 3.
2. Turn off all electric power to the appliance and set the thermostat to lowest setting.
3. Remove Control Access Panel from the boiler, fig. 1

Turn the gas control manual valve clockwise  to the full "OFF" position, fig. 2.

Wait five (5) minutes to clear out any gas. Then smell for gas, including near the floor. If you smell gas, **STOP!** Follow "B" in the safety information printed on page 5. If you do not smell gas, go to the next step.

4. Disconnect the pilot line from the gas control, fig.3.
5. Disconnect the ignitor cable from the S 8600 Honeywell Control box, fig. 3

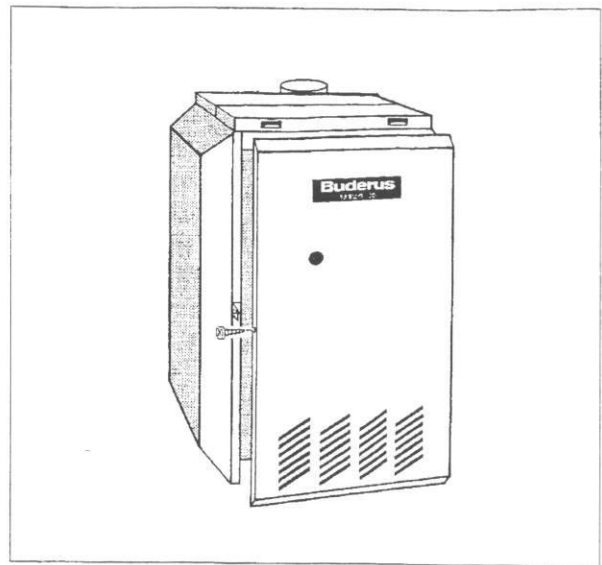

Fig.1

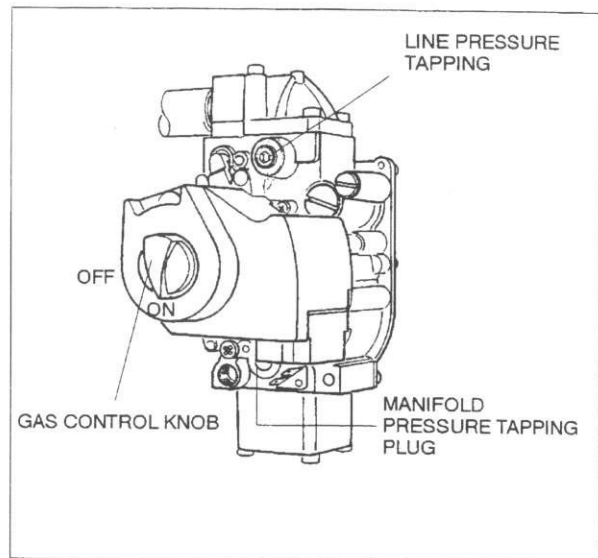

Fig.2

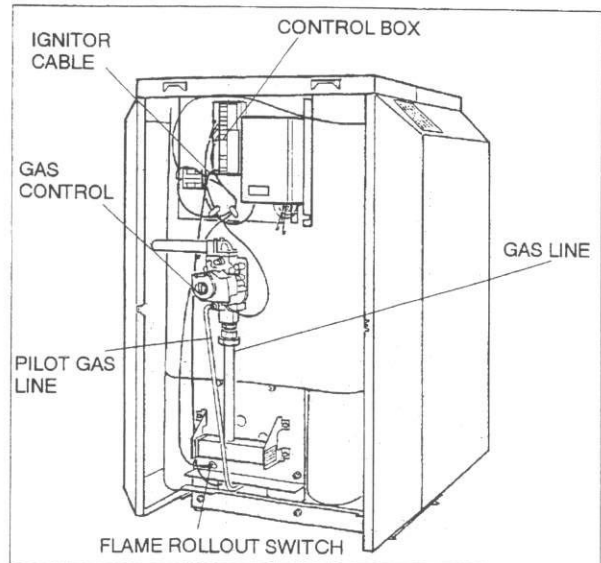

Fig.3

6. Remove the pressure regulator cap screw from the gas control, fig.4.
7. Remove the pressure regulator adjusting screw, fig.4.
8. Remove the stainless steel spring, fig.4.
9. Install the red spring contained in the Honeywell LP gas conversion kit into the gas control, fig.4.
10. Install the new pressure regulator adjusting screw flush with top of regulator.
11. Turn six (6) complete turns clockwise . This will supply a preliminary pressure of approximately 10.0 inches water column. The setting needs to be checked with a manometer after conversion of the manifold is completed.
12. Clean the gas control body and apply yellow label, shown below, to the gas valve so that it is easily visible.

ATTENTION
THIS VALVE HAS BEEN
CONVERTED FOR USE WITH
LP GAS.

13. Secure the gas supply piping to the slot in the top jacket panel with wire or rope.
14. Disconnect the union from the gas supply. Place the gasket from the union in a safe place.

Caution: Label all wires prior to disconnecting when servicing controls. Wiring errors can cause improper and dangerous operation.

15. Label the wires connected to the gas control and disconnect them from the gas control.
16. Remove the 4 nuts that secure the burner assembly from the boiler and remove the burner assembly from the boiler, fig.3 and fig.5.
17. Remove main gas orifices and washers from burner assembly fig.5.
18. Install new orifices and washers supplied with kit. Ensure orifices are the proper size for your boiler application per the following table:

Propane Gas Orifice Sizes			
Model	G124x-18	G124x-25	G124x-32
Orifice Size	1.80mm	1.75mm	1.70mm
Quantity	2	3	4

NOTE: These orifice sizes are for 0-8500 ft elevation only. For elevations 8501 ft – 120000 ft, see "Instructions for High Altitude".

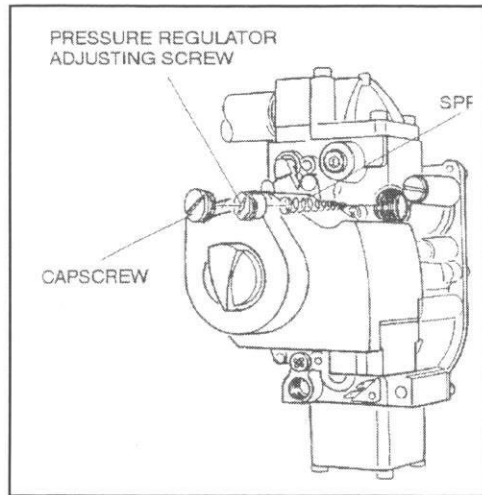

FIG 4.

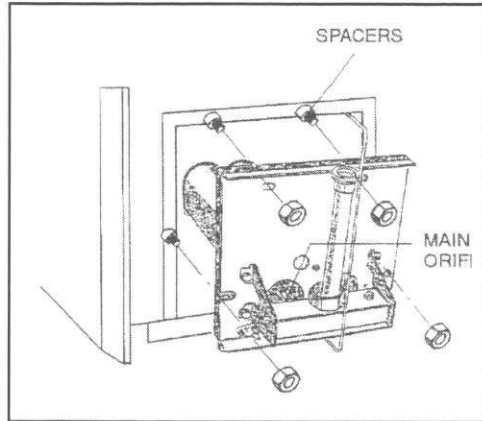

Fig. %

18. Disconnect the pilot gas line from the pilot assembly, fig. 6.
19. Remove pilot orifice.
20. Install new pilot orifice, BBR 12.
21. Install the pilot gas tubing in the pilot assembly.
22. Verify the pilot hood to main burner relationship shown in fig 6.
23. Install the burner assembly in the boiler in reverse order of removal. Ensure the spacers shown in fig. 5 are in place before installing the burner assembly in the boiler. Ensure the nuts are tightened firmly.
24. Reconnect the union between the gas valve and the manifold. Ensure that the gasket removed in step 13, is installed in the union.
25. Connect the flame roll – out switch wires to the flame roll-out switch.
26. Remove the wire or rope used to secure the gas supply piping in step 12.
27. Reconnect the pilot gas line to the gas valve, fig. 3.
28. Reconnect the ignitor cable to the S 8600 Honeywell Control box, fig. 3.
29. Fill out the required information on the conversion plate and affix the plate to the outside of the boiler jacket as close as possible to the existing rating plate.
30. If the boiler has not been placed into operation, follow the installation instructions in **"The Installation, Operation and Maintenance Manual"** supplied with the boiler. If the boiler has been in operation, then open the main gas shut-off valve. Test the gas piping on the input side of the gas control for leaks by applying a soap and water solution. If no leaks are found go to step 32. If any leaks are found, shut off the main gas piping shutoff valve.
31. Repair leaks and repeat step 30.
32. Shut off the main gas supply shut-off valve. Remove the line pressure tapping plug from gas control, fig. 2; install a test fitting, and hook up a manometer so that line pressure can be checked.
33. Remove the manifold pressure tapping plug from the gas control, install a test fitting and hook up a manometer so that manifold pressure can be checked, fig. 2.
34. Open the main gas piping shut-off valve and measure the supply pressure to the boiler. The supply pressure must be between 11 and 13 inches water column. If pressure is not between 11 and 13 inches water column, when boiler is running, call your service technician or gas supplier.
35. Follow the the lighting instructions next page.

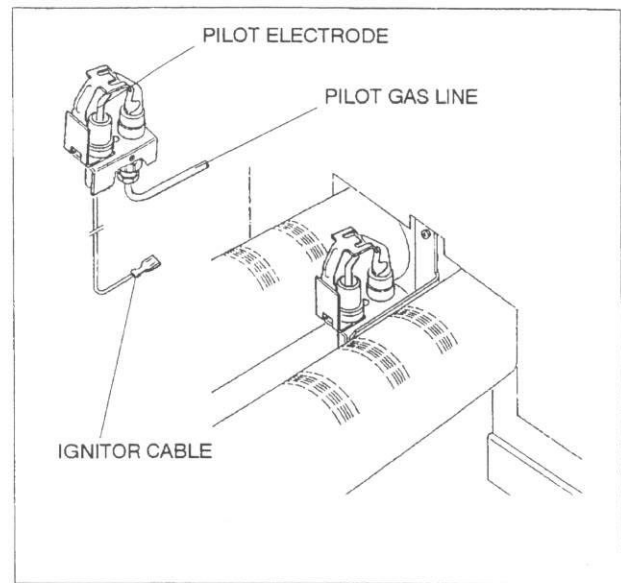

Fig.6: Pilot Assembly

Lighting Instructions

FOR YOUR SAFETY, READ BEFORE LIGHTING

WARNING: If you do not follow these instructions exactly, a fire or explosion may result causing property damage, personal injury or loss of life.

- A. This appliance is equipped with an ignition device which automatically lights the pilot. Do not try to light the pilot by hand.
- B. **BEFORE OPERATING** smell all around the appliance area for gas. Be sure to smell next to the floor because some gas is heavier than air and will settle on the floor.

WHAT TO DO IF YOU SMELL GAS

- Do not try to light any appliance.
 - Do not touch any electric switch, do not use any phone in your building.
 - Immediately call your gas supplier from a neighbor's phone. Follow the gas supplier's instructions.
 - If you cannot reach your gas supplier, call the Fire Department.
- C. Use only your hand to turn the gas control knob. Never use tools. If the knob will not turn by hand, don't try to repair it, call a qualified service technician. Force or attempted repair may result in a fire or explosion.
- D. Do not use this appliance if any part has been under water. Immediately call a qualified service technician to inspect the appliance and to replace any part of the control system and any gas control which has been under water.

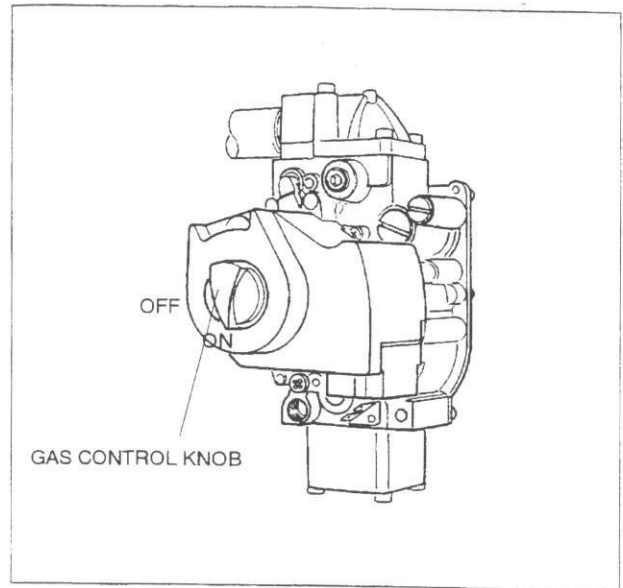







Fig.7

OPERATING INSTRUCTIONS

STOP! Read the safety information printed on page 5 in these instructions.

- 36 Wait five (5) minutes to clear out any gas. Then smell for gas, including near the floor. If you smell gas, **STOP!** Follow "B" in the safety information printed on page 5. If you do not smell gas, go to the next step.
- 37 Locate the pilot assembly by looking through the access hole in the burner assembly plate, fig.8.
- 38 Turn gas control knob counterclockwise  to "ON".
- 39 Turn on all electric power to the appliance.
- 40 Ensure that there is a call for heat from the thermostat control.
- 41 The ignition control should initiate sparking at the pilot. The pilot should light and then the main burners should light. If the main burners do not light, shut off the main gas piping shut-off valve. Shut off all electric power to the appliance, and call your service technician or gas supplier.
- 42 If the main burners light, then the gas fittings, union and orifices must be tested for leaks with a soap and water solution. If no leaks are found then go to step 44. If any leaks are found, turn gas control knob clockwise  to "OFF". Turn off all electrical power to the appliance.
- 43 Repair leaks. Repeat steps 36 through 42.
- 44 To verify the rate, the manifold pressure must be adjusted to the values shown in table 4. To adjust the manifold pressure, remove the capscrew from the gas control. Turn the pressure regulating adjusting screw clockwise  to increase, or counterclockwise  to decrease the manifold pressure. This adjustment must be made while the boiler is in operation.
- 45 After adjustment, install the capscrew on the gas control, fig.9.
- 46 Observe the pilot flame through hole in the burner assembly plate. The flame should envelop the flame sensor $\frac{1}{2}$ – $1\frac{1}{2}$ inch, fig. 10. If the pilot flame is satisfactory then go to step 47. If the pilot flame is too small or too large, adjust the pilot using the pilot adjustment screw., fig. 9. Turn the inner adjustment screw clockwise  to decrease, or counterclockwise  to increase the pilot flame. After adjustment, replace the cover screw and tighten firmly.

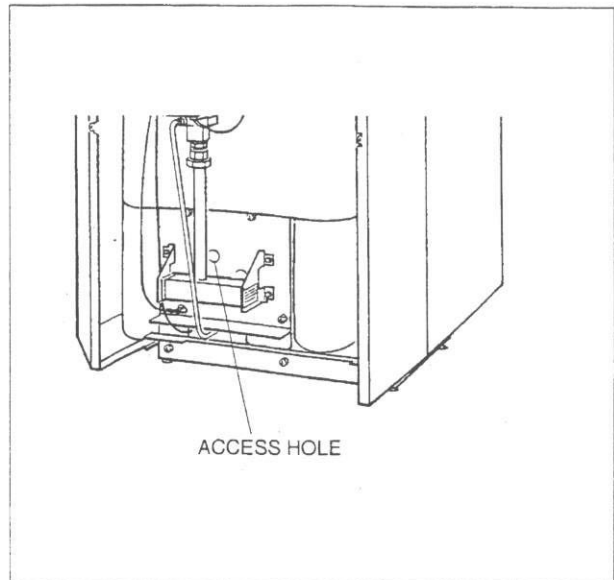

Fig.8

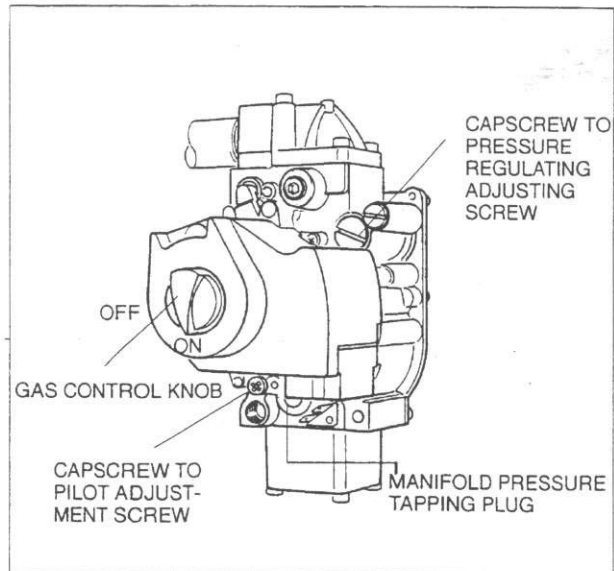

Fig.9

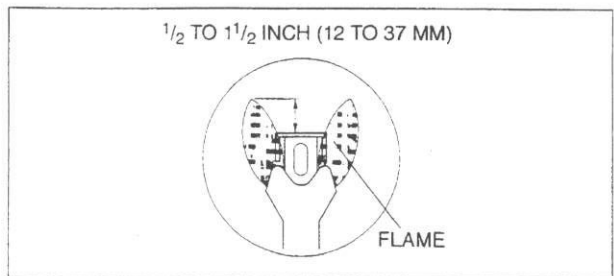



Fig.10

47. Observe the main burner flame through hole in the burner assembly plate. The flame should have a smooth, firm contour and be mostly blue in color. If the main burner flame is satisfactory, go to step 50. If main burner flame is lazy, yellow, or lifting off the burners, turn the gas control knob clockwise  to "OFF". Shut off the main gas piping shut-off valve. Disconnect all electric power to the appliance and call your service technician or gas supplier.

48. The ignition safety shut-off means must be tested. Test the safety shut-off by shutting off the main gas piping shut-off valve.

The main burner and the pilot flame will extinguish. Within six (6) seconds the gas control main gas solenoid should close and make an audible sound.

After 90 seconds, the module should go into lock out mode and spark should stop. Disconnect the electric power to the appliance. Open the main gas shut-off valve. Turn on the electric power to the unit. A normal operating sequence should occur. If the gas control functions satisfactorily then go to step 49. If the gas control does not function satisfactorily, immediately turn

the gas control knob clockwise  to "OFF". Shut off the main gas piping shut-off valve. Disconnect all electrical power to the appliance and call your service technician or gas supplier.

49 Turn the gas control knob clockwise  to "OFF".

50 Shut off the main gas piping shut-off valve.

51 Turn off electric power to the appliance.

52 Remove the pressure test fittings from the line pressure and manifold pressure taps in the gas control and replace the plugs.

53 Repeat steps 36 through 41, and 47 to place the appliance back on operation. Check the plugs in the gas control with a soap and water solution. If no leaks are found go to step 55. If any leaks are found, shut off the main gas piping shut-off valve and turn the gas knob clockwise  to "OFF". Turn off all electrical power to the appliance.

54 Repair leaks. Open the main gas shut-off valve and repeat step 53.

55 Wash off the soap and water solution used to test for leaks to ensure no corrosive affects from the soap.

56 Replace the control access panel.

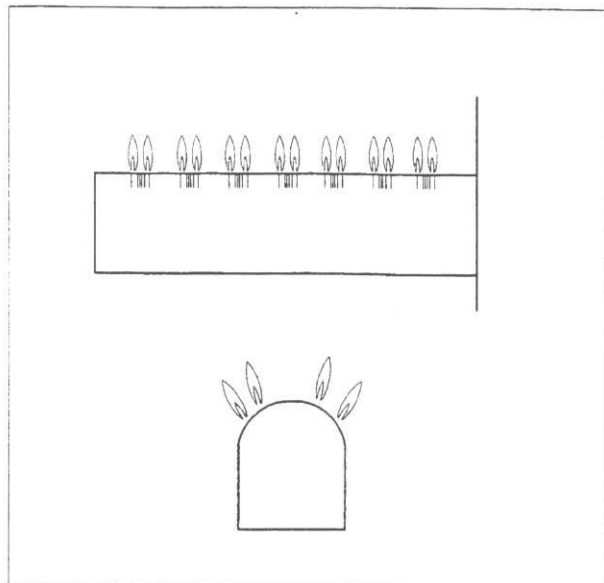
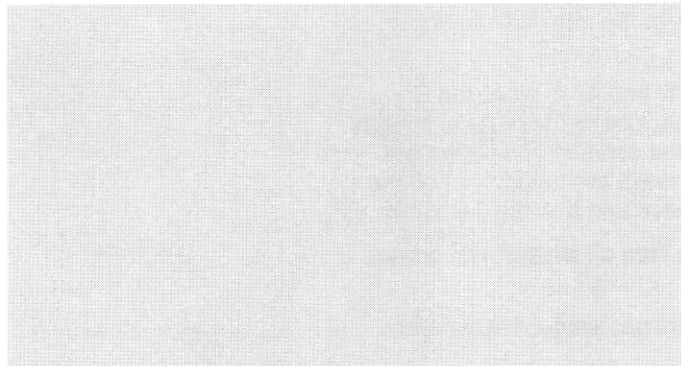

Fig. 11

Required Manifold Pressure

Model G124 X	Propane gas
18	9,8 Inches Water Column
25	10,3 Inches Water Column
32	10,0 inches Water Column

Table 4



Buderus

50 Wentworth Avenue
Londonderry, NH 03053
Phone: 603-552-1100 ■ Fax: 603-421-2719
www.buderus.net

*Buderus reserves the right to make changes without notice
due to continuing engineering and technological advances.*