

6 720 804 873-00.1T

DANGER!

If these instructions are not followed exactly, a fire or explosion may be caused with serious property damage or loss of life and serious injury. Do not store or use gasoline or any other flammable liquids or vapors in the vicinity of this system or any other heating system.

Logano G115 WS US/CA

6 720 804 873 (2019/09) EN-US



Buderus

Contents

1	General safety instructions and explanation of symbols	3
1.1	Explanation of symbols	3
1.2	Safety instructions	3

2	Product description	4
2.1	Intended use	4
2.2	Certification and testing mark	4
2.3	Disposal	4
2.4	Product description	4

3	Commissioning the heating system	5
3.1	Turning the heating system on	5
3.2	Checking the operating pressure, topping up the boiler water and bleeding air from the system	5
3.2.1	Checking the operating pressure	5
3.2.2	Topping up the boiler water and bleeding the system	5
3.3	Starting the heating system using the controls	6
3.4	Turning the heating system off	6
3.5	Action in an emergency	6
3.6	Operating tips	6
3.7	Why is regular servicing important?	7

4	Troubleshooting	7
4.1	Identifying operating modes and resetting faults	7

1 General safety instructions and explanation of symbols

1.1 Explanation of symbols



Warnings are indicated by a warning triangle and a grey background.

Signal words are used to indicate the level of risk if counter measures are not taken.

- **Caution** indicates that minor damage to property may occur.
- **Warning** indicates that minor personal injury or severe damage to property may occur.
- **Danger** means that severe personal injury may occur. Very serious cases may result in death.



Notes are identified in the text by this symbol. They are separated by horizontal lines above and below the text.

Notes contain important additional information.

Notes do not contain any warnings or information about hazards or risks.

1.2 Safety instructions

If you smell flue gas

- ▶ Switch off the boiler (→ page 6).
- ▶ Open windows and doors.
- ▶ Inform an authorized heating contractor.

Installation

- ▶ Correct and proper installation and adjustment of the burner and the controls are the fundamental requirements for safe and economical operation of the boiler.
- ▶ The boiler may only be installed or converted by an approved heating contractor.
- ▶ Do not modify any parts that carry flue gas.
- ▶ The hot water tank may only be used for heating domestic hot water.
- ▶ **Never shut off safety valves!**
Water must be able to escape from the safety valve for the hot water system and piping when the water is being heated.

Maintenance and servicing

Heating systems should be regularly maintained for the following reasons:

- to maintain a high level of efficiency and to operate the system economically (low fuel consumption),
- to achieve a high level of operational reliability,
- to maintain the cleanest combustion.
- ▶ sign a maintenance and servicing contract with an approved heating contractor covering annual servicing and maintenance.
- ▶ The flue system must be inspected once a year. Have all parts that show any signs of damage from corrosion or other causes replaced.
- ▶ The boiler must be serviced by qualified boiler service company once a year. Servicing must include the burner, the entire flue and combustion air system and any air inlet/outlet vents. All parts that show any signs of damage from corrosion or other causes must be replaced.

Recommendation for users:

- ▶ Servicing and repairs may only be carried out by a trained heating contractor.
- ▶ Have any faults immediately corrected in order to prevent damage to the system.
- ▶ The operator is responsible for the general and environmental safety of the heating system.
- ▶ Use only genuine Buderus spare parts. Damage caused by the use of parts not supplied by Buderus is not covered by the Buderus warranty.

Danger by failing to consider your own safety in an emergency such as a fire

- ▶ Never put yourself at risk. Your own safety must always take the highest priority.

Dangers posed by explosive and flammable materials

- ▶ Any work on components that carry oil may only be carried out by a certified heating contractor.
- ▶ Do not use or store flammable (paper, thinners, paints, etc.) near the boiler.
- ▶ Maintain a clearance of at least 16 inches from the boiler.

Risk of poisoning. Insufficient ventilation may cause dangerous flue gas leaks.

- ▶ Never close off or reduce the size of air inlet or outlet vents.
- ▶ The boiler must not be operated until the obstruction has been removed.

Danger to life from carbon monoxide

Carbon monoxide (CO) is a poisonous gas, which arises during the incomplete combustion of fossil fuels such as oil, gas or solid fuels.

Dangers arise, if carbon monoxide escapes from the heating system due to a fault or a leak and collects unnoticed in enclosed spaces.

You can neither see, taste nor smell carbon monoxide.

To avoid danger from carbon monoxide:

- ▶ Have the heating system inspected and serviced regularly by an approved contractor.
- ▶ Use a CO detector, which gives an alarm in good time if CO escapes.
- ▶ If you suspect a CO leak:
 - Warn your neighbours and leave the building immediately.
 - Call an approved contractor.
 - Have any defects rectified.

Risk of water damage

- ▶ Do not use the appliance if any part of it has been under water.
- ▶ Call in a qualified customer service technician immediately to check the appliance and replace any controls that have been under water.

Combustion air

- ▶ Keep the combustion air free of corrosive substances (e. g. halogenated hydrocarbons that contain chlorine or fluorine compounds). In that way you will prevent corrosion.

Instructing the operator

- ▶ The operator must read the information on how the boiler works and have the heating system installer explain how to operate it.

2 Product description

To ensure safe, economical and environmentally friendly use of the heating system, we recommend that you carefully read the safety instructions and operating instructions.

These instructions provide the operator of the heating system with an overall view of the use and operation of the boiler.

2.1 Intended use

The boiler is designed for heating central heating system water and domestic hot water, in residential buildings or apartment buildings, and light commercial installations. Other uses are not intended.

2.2 Certification and testing mark

This appliance has been tested and certified to meet rules and regulations in place for the US and Canadian markets.



2.3 Environmental protection and disposal

Environmental protection is one of the fundamental company policies of the Bosch Group.

Quality of products, efficiency and environmental protection are equally important objectives for us. Environmental protection laws and regulations are strictly adhered to.

To protect the environment, we use the best possible technology and materials taking into account economic points of view.

Packaging method

For the packaging, we participate in the country-specific recycling systems, which guarantee optimal recycling.

All packaging materials used are environmentally-friendly and recyclable.

Old appliances

Old appliances contain valuable materials that can be recycled. The components are easy to separate. Plastics are identified. This allows the various assemblies to be sorted and recycled or disposed of.

Old electrical and electronic appliances

 This symbol indicates that the product must not be disposed of with other waste, but be taken to the waste collection centers for treatment, collection, recycling and disposal procedure.

The symbol applies to countries with electronic waste regulations, for example the European Waste Electrical and Electronic Equipment Directive 2012/19/EU. These regulations determine the framework for the return and recycling of used electronic appliances as applicable within each country.

As electronic equipment may contain hazardous substances, it needs to be recycled responsibly in order to minimize any potential harm to the environment and human health. Furthermore, recycling of your electronic waste will help to conserve natural resources.

For additional information on the environmentally safe disposal of electrical and electronic equipment, please contact the relevant local authorities, your household waste disposal service or the retailer where you purchased the product.

For additional information, please visit:
www.weee.bosch-thermotechnology.com/

Batteries

Batteries must not be disposed together with your household waste. Used batteries must be disposed of in local collection systems.

2.4 Product description

The boiler (→ Fig. 1) is a low-temperature oil-fired appliance.

The main components of the boiler (→ Fig. 1) are:

- Control panel
- Boiler jacket
- Boiler heat exchanger with insulation

The controls monitors the boiler and system water temperatures and controls the burner. It also includes the safety devices.

The boiler can alternatively be fitted with a simple Aquasmart control.

The boiler jacket prevents heat loss and reduces noise.

The boiler heat exchanger transfers the heat generated by the burner to the heating water. The thermal insulation reduces radiant and standby heat loss.

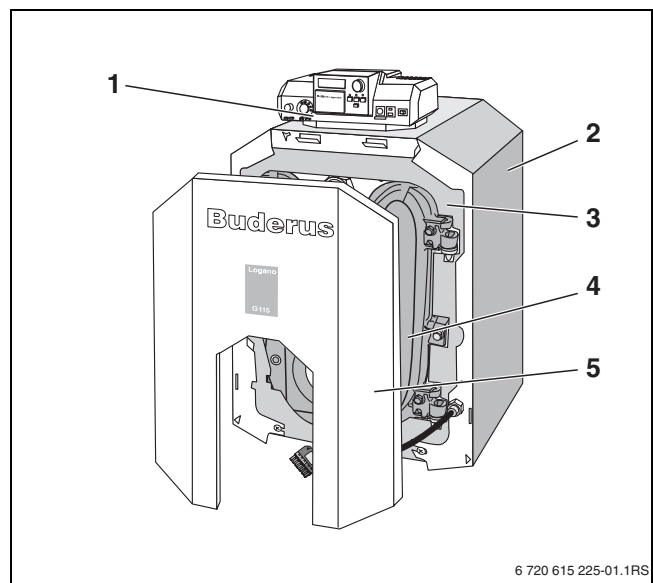

Fig. 1 Boiler without burner

- [1] Control panel R2107 (sold separately)
- [2] Boiler jacket
- [3] Boiler heat exchanger with insulation
- [4] Burner door
- [5] Burner door panel

3 Commissioning the heating system

3.1 Turning the heating system on

Before switching on, ensure that:

- the operating water pressure is sufficient,
- the fuel supply has been turned on at the main shut-off valve, and
- the heating system emergency shut-off switch is in the ON position.

3.2 Checking the operating pressure, topping up the boiler water and bleeding air from the system

The water used for filling the heating system loses a substantial amount of volume in the first few days due to the release of its gas content. This causes air pockets to form and the heating system starts to make noises.

- ▶ With new heating systems, check the operating pressure daily at first, topping up the boiler water and bleeding the system and radiators (if so equipped).
- ▶ Later on, check the operating pressure monthly, topping up boiler water and bleeding the boiler and radiators (if so equipped).

3.2.1 Checking the operating pressure

Your heating contractor will have set the system to the required operating pressure of at least 15 psi (1 bar) and entered the setting in Tab. 1, page 5.

- ▶ Read the current operating pressure (psi) and temperature (°F) from the temperature/pressure gauge.
- ▶ If the temperature/pressure gauge needle drops below the minimum pressure marker of 15 psi, the operating pressure is too low. Top up the system until the contractor's selected operating pressure is reached.

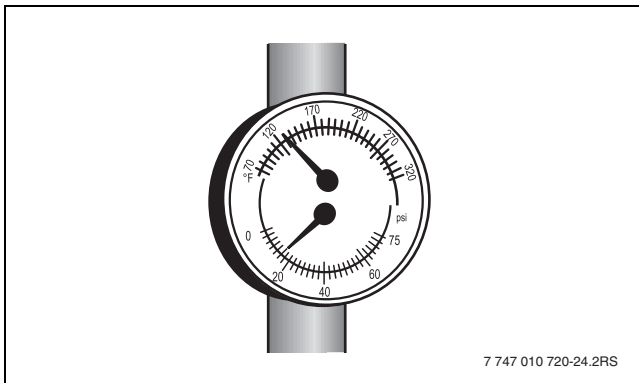

Fig. 2 Pressure/temperature gauge

3.2.2 Topping up the boiler water and bleeding the system

Ask your heating contractor to show you where the boiler fill & drain valve for topping up the heating system is located in your heating system.



CAUTION: Health risk from contaminated domestic water.

- ▶ It is imperative that you observe all regulations and standards applicable in your country regarding prevention of domestic water contamination.



CAUTION: Risk of damage to system due to temperature stress.

If you fill the heating system when it is hot, the resulting temperature stress can cause stress cracks and a leak in the boiler.

- ▶ Only fill the heating system when cold (the flow temperature should be no more than 100 °F).

- ▶ If there the fill valve is not hard piped to the water supply, you will need to connect a hose.
- ▶ Fill the heating system by slowly opening the fill valve. Observe the pressure gauge (pressure/temperature gauge) while doing so.
- ▶ Close the boiler fill valve once the required operating pressure has been reached.
- ▶ Bleed the system via the air vent and the radiator bleed valves (if so equipped).
- ▶ Top up with additional water if the pressure drops as a result of bleeding the system.



CAUTION: Risk of system damage due to frequent topping up.

If you have to top up the heating water frequently, the heating system may suffer damage from corrosion or scaling due to repeated introduction of oxygen.

- ▶ Ask your heating contractor if the local water can be used untreated or whether it needs to be treated.
- ▶ Notify your heating contractor if you find you need to top up your heating system frequently, as there may be a leak.

Operating pressure	
Design operating pressure (optimum setting)	_____ psi
Maximum heating system operating pressure (standard = 30 psi)	_____ psi

Table 1 Operating pressure (entered by system installer)

3.3 Starting the heating system using the controls

Switching on the controls automatically places the burner on standby. The burner is then ready to start. For more information, consult the instruction manual for the controls and the burner.

- ▶ Set the boiler temperature control to "AUT" (Automatic mode). In that setting, the controls operates the boiler.
- ▶ Set the ON/OFF switch to position "I" (ON).



Information on operating the system, e.g. setting the temperatures, can be found in the controls' documentation.

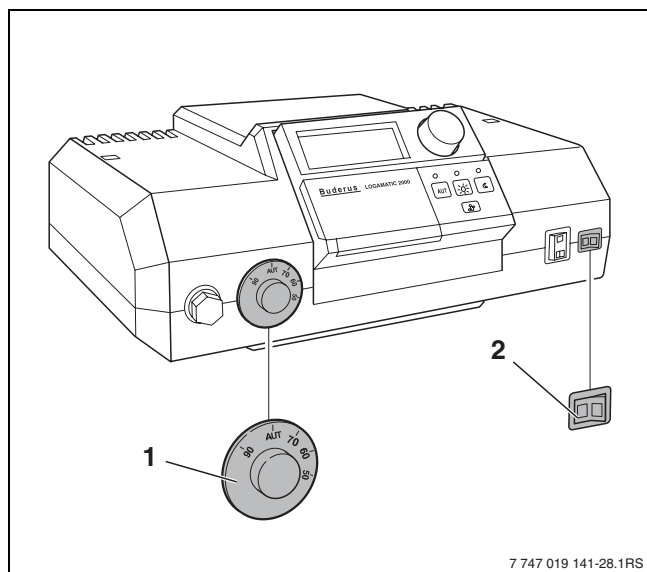

Fig. 3 Switching on the controls (e.g. Logamatic 2000)

Starting up the system using the Aquasmart control

- ▶ Switch on emergency shut-off switch ("ON" position). This turns on the heating system.

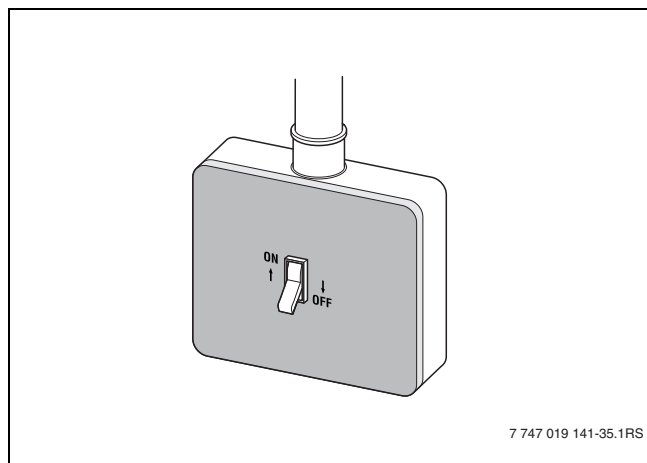

Fig. 4 Switching the heating system on/off using the emergency shut-off switch (without Buderus controls)

3.4 Turning the heating system off

With Buderus controls (→ Fig. 3, page 6)

- ▶ Switch off the on/off switch on the controls (position "0"). This switches off the boiler and all its components (such as the burner).

With Aquasmart control (→ Fig. 4, page 6)

- ▶ Switch off the emergency shut-off switch ("OFF" position). This switches off the boiler and all its components.

Completing final operations

- ▶ Shut off fuel supply by closing main valve.



CAUTION: Risk of system damage from freezing. If the heating system has been switched off, it may freeze up.

- ▶ Leave the heating system permanently switched on as much as possible.
- ▶ Protect your heating system against freezing by draining the heating system and hot water pipes at the lowest point.

3.5 Action in an emergency



Use the heating system emergency shutoff switch located outside the boiler room or the heating system circuit-breaker for emergency shutdown.

In the event of an emergency, e. g. a fire, proceed as follows:

- ▶ Never put yourself at risk of fatal injury. Your own safety must always take the highest priority.
- ▶ Shut off fuel supply by closing main valve.
- ▶ Isolate the heating system from the mains power supply by means of the heating system emergency stop switch or the appropriate electrical fuse/circuit breaker.

3.6 Operating tips

The right fuel

To ensure it operates properly, the heating system requires fuel of the correct type and grade.



CAUTION: Risk of system damage from use of incorrect fuel.

- ▶ Only use the fuel specified. The correct fuel is entered in Tab. 2 by the heating system installer.

Use only this fuel

Stamp/Date/Signature

Table 2 Fuel to be used (entered by heating system installer)

Information on the boiler room



CAUTION: Risk of boiler damage from contaminated combustion air.

- ▶ Keep the combustion air free of corrosive substances (e.g. halogenated hydrocarbons that contain chlorine or fluorine compounds).
- ▶ Prevent heavy accumulation of dust.



CAUTION: Risk of system damage from water.

- ▶ In the event of severe risk of flooding, disconnect the boiler from its power supply and shut off the fuel supply before water enters the boiler room.
- ▶ After the flood has subsided, ask your installer to check the heating system before starting it up again.
- ▶ All parts that have been in contact with flood water must be replaced by a qualified heating contractor.

3.7 Why is regular servicing important?

Heating systems should be regularly maintained for the following reasons:

- to achieve a high level of efficiency,
- to operate the system economically (low fuel consumption),
- to maintain the cleanest possible combustion.



CAUTION: Risk of system damage due to lack of or inadequate cleaning and maintenance.

- ▶ Have your heating system inspected, cleaned and maintained by a heating contractor once a year.
- ▶ We recommend you sign a contract covering an annual inspection and maintenance on an as-required basis.

4 Troubleshooting

4.1 Identifying operating modes and resetting faults

Two type of fault are distinguished:

- Burner faults and
- Control and heating system faults

If there is a burner fault the fault indicator lamp on the burner comes on (→ burner documentation). Such faults can generally be reset by pressing the reset button on the burner.

Controls and heating system faults are indicated on the control unit display if it has one. More detailed information can be found in the controls' documentation.

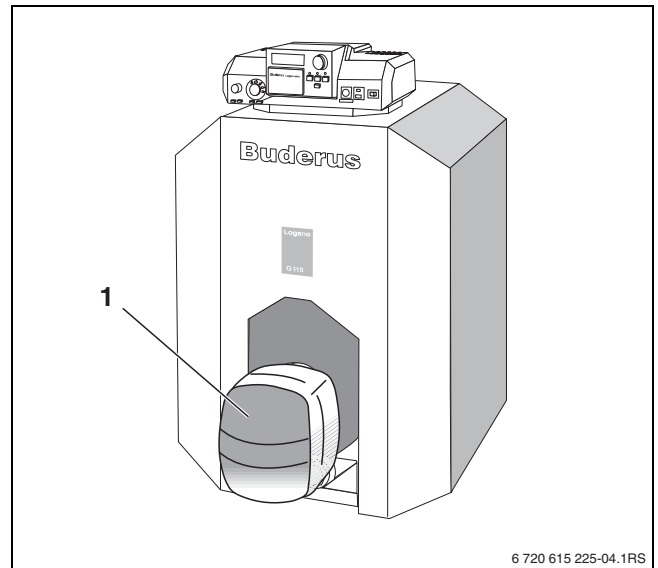

Fig. 5 Resetting the burner

[1] Burner

Correcting burner faults

- ▶ Press reset button on burner.



CAUTION: Risk of system damage due to too many resets. Always follow the burner manufacturer's instructions.

Too many resets can damage the burner's ignition transformer.

- ▶ Do not press the reset button more than three times in a row. If the fault does not reset after the third attempt, localize and rectify the fault with the help of the burner documentation. Notify a service contractor if necessary.



CAUTION: Risk of system damage from freezing. The heating system can freeze up in cold weather if it has been switched off or disabled by a fault shutdown.

- ▶ Rectify the fault immediately and restart the heating system.
- ▶ If that is not possible, protect the heating system against freezing by draining it at the lowest point.



Canadian installations of this boiler are required to be equipped with a blocked vent switch (WMO) that interrupts the burner in case of an obstructed flue gas pipe. Call your boiler service technician if you suspect the WMO may have tripped.

United States and Canada

Bosch Thermotechnology Corp.
50 Wentworth Avenue
Londonderry, NH 03053
Tel. 603-552-1100
Fax 603-965-7581
www.buderus.us
U.S.A.

Products manufactured by
Bosch Thermotechnik GmbH
Sophienstrasse 30-32
D-35576 Wetzlar
www.buderus.com

Bosch Thermotechnology Corp. reserves the right
to make changes without notice due to continuing
engineering and technological advances.

Buderus