

Installation and maintenance instructions

Sealed combustion gas boiler Logano GA124

CAUTION!

Observe the safety instructions of this installation and maintenance manual before placing the boiler in operation.

WARNING!

If installation, adjustment, modification, operation or maintenance of the heating system is carried out by an unqualified person, this may result in danger to life and limb or property damage. The directions of this installation and maintenance manual must be followed precisely. Contact a qualified service company, service provider or the gas company if support or additional information is required.

CAUTION!

The operating manual is a component of the technical documentation handed over to the operator of the heating system. Discuss the instruction in this manual with the owner or operator of the heating system to ensure that they are familiar with all information required for operation of the heating system.



Note: Keep this installation and maintenance manual available for future reference.

Buderus

Please read carefully prior to installation and maintenance.

1	Safety	4
1.1	Correct use	4
1.2	Observe the following symbols	4
1.3	Please observe these notes	4
1.4	Tools, materials and accessories	6
1.5	Disposal	6
2	Product description	7
3	Dimensions and connections	8
4	Scope of delivery	9
5	Moving the boiler	10
5.1	Moving the boiler with boiler cart	10
5.2	Lifting and carrying the boiler	11
6	Placing the boiler	12
6.1	Clearances	12
6.2	Leveling the boiler	13
7	Boiler installation	14
7.1	Preparing for installation	14
7.2	Heating circuit connection	15
7.3	Electrical connection	17
7.4	Fuel supply connection	18
7.5	Installation of flue system	20
7.6	Filling heating system and checking for leaks	29
8	Openings for combustion air supply and venting	31
9	Placing the heating system in operation	33
9.1	Start-up instructions	35
9.2	Making boiler ready for operation	36
9.3	Then carry out start-up procedures	36
9.4	Shutting off gas supply to boiler	40
9.5	Instruct owner/operator and hand over technical documentation	41
9.6	Start-up protocol	42
10	Taking the boiler out of operation	43
10.1	Normal boiler shut-down	43
10.2	Emergency shut-down	43
11	Boiler inspection and maintenance	44
11.1	Why is regular maintenance important?	44
11.2	Testing the flue system, including combustion air, air inlets and Ventilation openings	44
11.3	Inspection of the boiler and burner	44
11.4	Preparing boiler for cleaning	45

Contents

11.5	Cleaning the boiler	46
11.6	Cleaning the burner	50
11.7	Troubleshooting.	51
11.8	Maintenance protocol	55
12	Specifications	57
13	Wiring diagrams	58

1 Safety

Observe these instructions for your safety.

The burner and control must be correctly installed and adjusted to ensure safe and economical operation of the gas-fired boiler.

Read this installation and maintenance manual carefully and note the details on the boiler nameplate before placing the boiler in operation.

1.1 Correct use

The Logano GA124 gas-fired boiler is designed to heat water for a hot water heating system for heating single or multiple occupancy buildings.

1.2 Observe the following symbols

Two levels of danger are identified and signified by the following terms:



WARNING!

RISK TO LIFE

Identifies possible dangers emanating from a product, which might lead to serious injury or death if appropriate care is not taken.



CAUTION!

RISK OF INJURY/ SYSTEM DAMAGE

Identifies potentially dangerous situations, which might lead to medium or slight injuries or to material losses.

Additional symbols for identification of dangers and user instructions:



WARNING!

RISK TO LIFE

from electric shock.



USER NOTE

Tip for the optimum utilization and setting of the control(s) plus other useful information.

1.3 Please observe these notes

1.3.1 National regulations

The heating system must comply with the relevant regulations issued by national authorities, or the regulations issued by the National Fuel Gas Code, ANSI Z 223.1. In Canada the regulations of CAN/CGA B 149.1 or 2, Installation Code for Gas Burning Appliances and Equipment, must be observed.

If specified by the local regulatory authorities the heating system must comply with the regulations of the "Standard for Controls and Safety Devices for Automatically Fired Boilers", ANSI/ASME CSD-1.

Carbon monoxide detectors must be installed as specified by the local regulations. The boiler must be serviced annually; see Chapter 11 "Boiler inspection and maintenance", page 44.

Boiler operating conditions

Maximum boiler temperature	210 °F
Maximum operating pressure	58 psi

The hot water pipe system must comply with the current legislation and regulations. If an existing boiler is replaced, the complete hot water pipe system must be inspected to ensure that it is in perfect condition to ensure safe operation.



WARNING!

RISK TO LIFE

due to neglecting your own safety in case of emergency, such as with a fire.

- Never put yourself at risk. Your own safety must always take priority.

**WARNING!****RISK TO LIFE**

from explosion of flammable gases.

If you smell gas there is a danger of explosion..

- Never work on gas lines unless you are licensed for this type of work..
- Make sure that a qualified company installs the boiler, connects gas and venting, places the boiler in operation, connects the electrical power, and maintains and repairs the boiler.
- No open flame. No smoking. Do not use lighters.
- Prevent spark formation.
Do not operate electrical switches, including telephones, plugs or door bells.
- Shut off main gas supply valve.
- Open doors and windows.
- Warn other occupants of the building, but do not use door bells.
- Call gas company from outside the building.
- If gas can be heard escaping, leave the building immediately, prevent other people from entering, notify police and fire from outside the building.

**CAUTION!****SYSTEM DAMAGE**

due to incorrect installation.

- Observe all current standards and guidelines applicable to the installation and operation of the heating system as applicable in your country.

**WARNING!****RISK TO LIFE**

from electric shock.

- Disconnect the power supply to the heating system before conducting any work on it, e.g. switch off the heating emergency switch outside the boiler room.
- It is not sufficient just to switch off the control.

**CAUTION!****SYSTEM DAMAGE**

due to unsatisfactory cleaning and maintenance.

- Clean and service the system once a year. Check that the complete heating system operates correctly.
- Immediately correct all faults to prevent system damage.

**USER NOTE**

Only use original Buderus spare parts. Losses caused by the use of parts not supplied by Buderus are excluded from the Buderus warranty.

1.3.2 Installation notes**WARNING!****RISK TO LIFE**

from explosion of flammable gases.

- Never work on gas lines unless you are licensed for this type of work.

**WARNING!****RISK TO LIFE**

from electric shock.

- Do not carry out electrical work unless you are qualified for this type of work.
- Before opening a unit: disconnect electrical power completely and lock to prevent accidental reconnection.
- Observe the installation regulations.

1.3.3 Information on the boiler room



WARNING!

RISK TO LIFE

by poisoning.

Insufficient ventilation during operation requiring room ventilation may cause dangerous flue gas leaks.

- Make sure that inlets and outlets are not reduced in size or closed.
- If faults are not corrected immediately, the boiler must not be operated.
- Inform the system operator of the fault and the danger in writing.



WARNING!

RISK TO LIFE

by poisoning.

When working on the flue gas monitoring equipment leaking flue gas may endanger the lives of people.

- Do not attempt to repair the flue gas temperature sensor.
- Use only original parts when replacing parts.
- When replacing the flue gas temperature sensor install the new one in the specified position.



WARNING!

RISK TO LIFE

by poisoning by leaking flue gas.

If the flue gas monitor trips frequently, there may be a problem with the chimney or the flue gas venting.

- If the flue gas monitor trips frequently the fault must be corrected and a function test must be conducted.



WARNING!

RISK TO LIFE

by poisoning by leaking flue gas.

- Make sure that the boiler is not fitted with a thermally controlled flue gas baffle after the back flow check.



WARNING!

FIRE DANGER

due to flammable materials or liquids.

- Make sure that there are no flammable materials or liquids in the immediate vicinity of the boiler.

1.4 Tools, materials and accessories

You need standard tools for the installation and maintenance of the boiler as used in heating system installation and oil, gas and water installations.

The following additional items will also be useful.

- Boiler cart with rope or Buderus boiler cart
- Cleaning brushes and/or chemical cleaning agents for wet cleaning

1.5 Disposal

- Dispose of the packaging material in an environmentally compatible fashion.
- Dispose of any components of the heating system that require replacement in an environmentally compatible fashion.

2 Product description

The boiler is a low temperature gas-fired boiler.



USER NOTE

The boiler is fully functional with the factory-installed aquasmart.

The boiler consists of:

- Aquasmart (control unit)
- Boiler jacket and front panel
- Boiler block with insulation
- Burner

The control monitors and controls all electrical components of the boiler.

The boiler jacket prevents energy loss and acts as soundproofing.

The boiler block transfers the heat generated by the burner to the heater water. The insulation prevents energy loss.

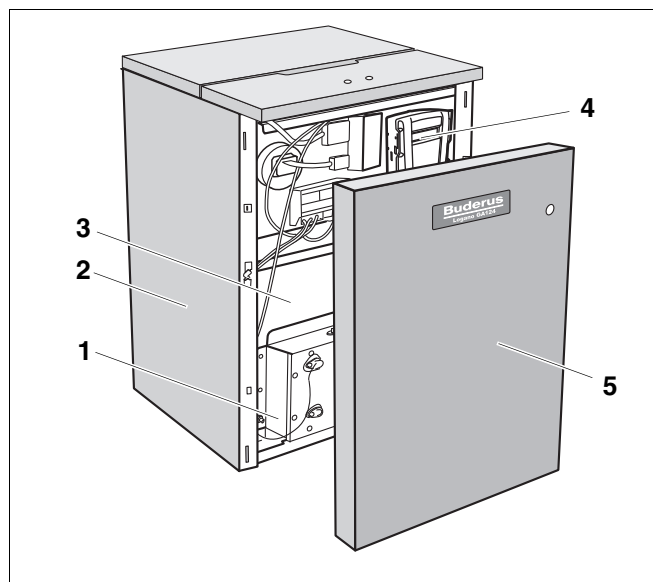

Fig. 1 Logano GA124 boiler

- 1 Burner
- 2 Boiler jacket
- 3 Boiler block with insulation
- 4 Aquasmart (control unit)
- 5 Boiler front panel

3 Dimensions and connections

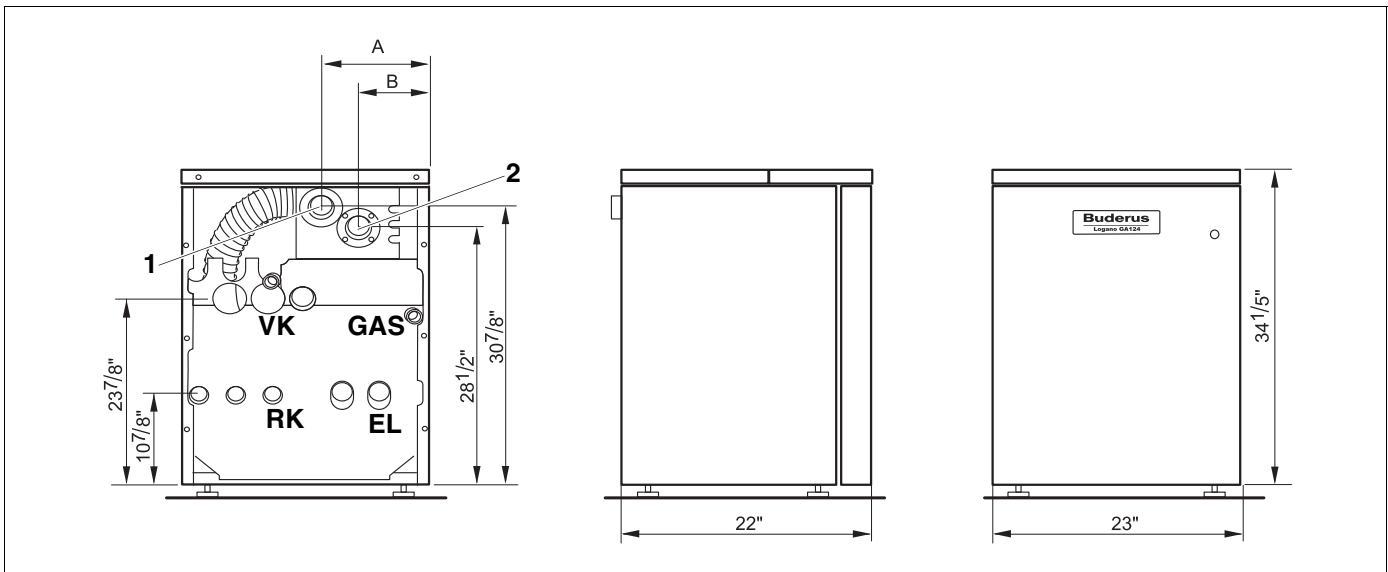

Fig. 2 Back, side and front view, measurements in inches

- 1 Combustion air line connection
- 2 Flue gas line

Connections (measurements see the following tables):

- VK = Boiler supply - 1"
- RK = Boiler return - 1"
- EL = Drain - 1/2"
- GAS = Gas connection - 1/2"

Boiler size	Boiler output	Combustion air connection	Flue gas connection	A	B	Min. overflow valve cap.	Number of orifices	Water volume	Empty weight
	MBtu/hr	Inches	Inches	Inches	Inches	lb/hr	Qty	US gal.	lbs
17	59	3"	3"	7 1/5"	3 1/10"	62	2	2.4	229
23	79	3"	3"	8"	6 2/3"	86	3	2.9	240
30	104	3"	3"	9 1/5"	10 1/5"	110	4	3.4	337

Tab. 1 Dimensions



USER NOTE

For the size and dimensions of the main gas orifice see → Chapter 12, page 57.

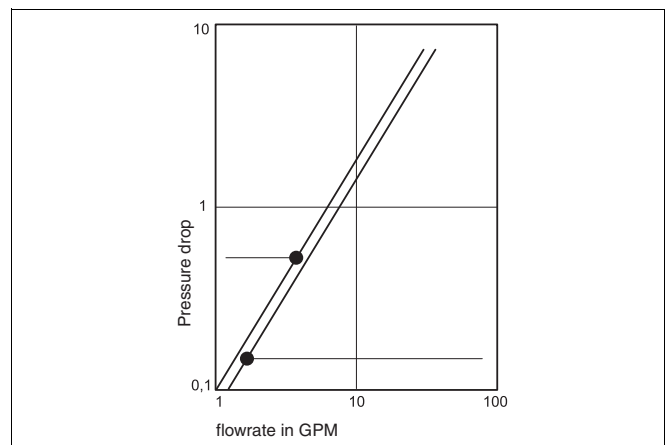

Fig. 3 Pressure gradient

4 Scope of delivery

- Check packaging on delivery for damage.
- Check delivery for completeness.

Component	Qty	Packaging
Boiler, complete	1	1 pallet
B-kit components: - supply manifold - 30 psi relief valve - temperature/pressure gauge - 90° elbow (1" NPT) - 90° elbow (3/4" NPT) - boiler drain (3/4") - screw-in feet (4) (M10x51)	1	1 foil package ¹
- wall penetration for horizontal flue system	1	separate packaging unit
- technical documents	1	1 foil package

Tab. 2 Scope of delivery

¹On pallet

Optional Accessories ¹	Unit
Heat circulation pump	1
Cleaning brush	1
Vertical flue system	1

Tab. 3 Accessories

¹ Accessories available by separate order

5 Moving the boiler

This chapter describes how to move the boiler safely,



CAUTION!

SYSTEM DAMAGE

due to bumps.

- Check the transport diagrams on the packaging to protect the sensitive components from damage by bumping.



USER NOTE

- Protect the boiler connections from dirt if the boiler is not installed immediately.



USER NOTE

Dispose of the packaging material in an environmentally compatible fashion.

5.1 Moving the boiler with boiler cart

Move the boiler with packaging and on pallet as much as possible.



CAUTION!

RISK OF INJURY

if the boiler is not properly secured to the boiler cart.

- Use suitable transport equipment, such as a boiler cart with a belt.
- Secure the boiler to prevent it from falling.
- Position transport equipment (e.g. boiler cart) at the back of the boiler.
- Secure boiler to cart.
- Move the boiler to the installation location.

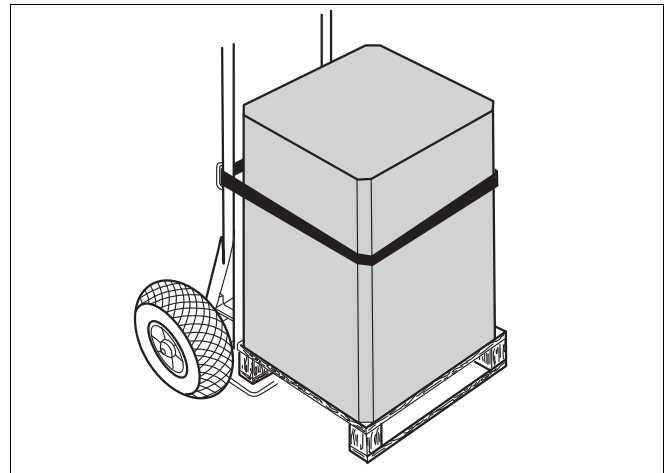

Fig. 4 Moving boiler with trolley

Moving the boiler

- Remove the straps and the cardboard packaging.
- Remove the bolts from the pallet.
- Lift the boiler at the sides and slide to the edge of the pallet. Place a pipe under the boiler and roll it on additional pipes to the installation location.
- Place the boiler in its final position.

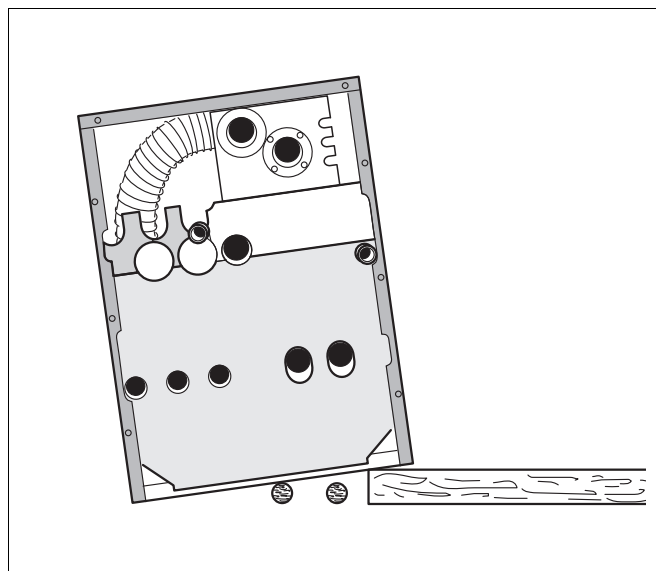

Fig. 5 Moving the boiler

5.2 Lifting and carrying the boiler

The boiler can be picked up at the hand grips shown.



CAUTION!

RISK OF INJURY

due to carrying heavy loads.

- Lift and carry the boiler with at least four people at the designated hand grip positions.

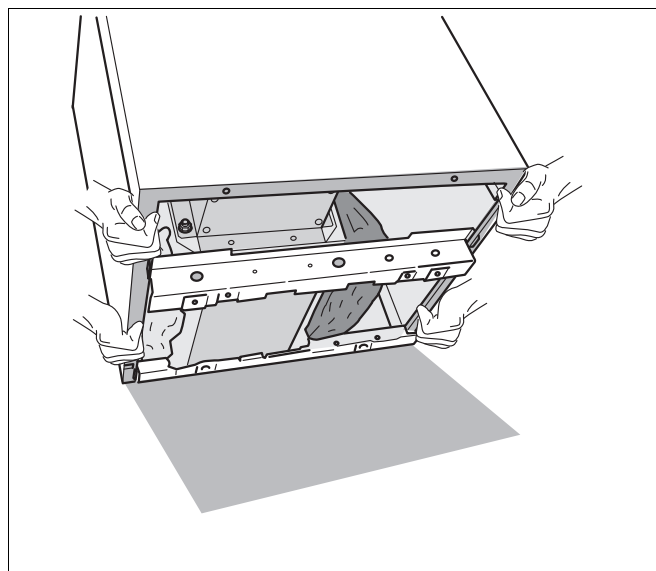

Fig. 6 Lifting and carrying the boiler

6 Placing the boiler

This chapter explains how to place the boiler and position it in the boiler room.



SYSTEM DAMAGE

through frost.

CAUTION!

- Place the boiler in a frost-free room.

This boiler is approved for installation in enclosed rooms, such as storage rooms.

The boiler is very heavy when full. Check that the floor can bear the weight before installation.

6.1 Clearances

A space of at least 33 inches is required in front of the boiler with the door open to allow sufficient access space for operation and maintenance. When the door is closed, a minimum clearance of 2 inches is required at the front and sides, 2 inches clearance is also required for the flue pipe and 18 inches clearance to the ceiling. The installation location and the base must be smooth and horizontal. The boiler may be installed on a flammable base, but not on carpet.

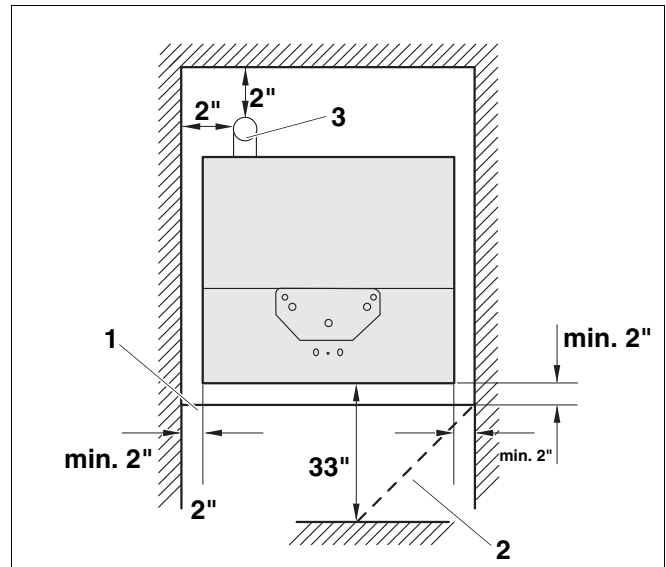

Fig. 7 Required clearances in the boiler room

- 1 Door closed
- 2 Door open
- 3 Flue pipe

6.2 Leveling the boiler

- Screw the four rubber feet 0.25 to 1.0 inches into the bottom rails.
- Place boiler on the feet.
- Level boiler horizontally and vertically by screwing the feet in and out.

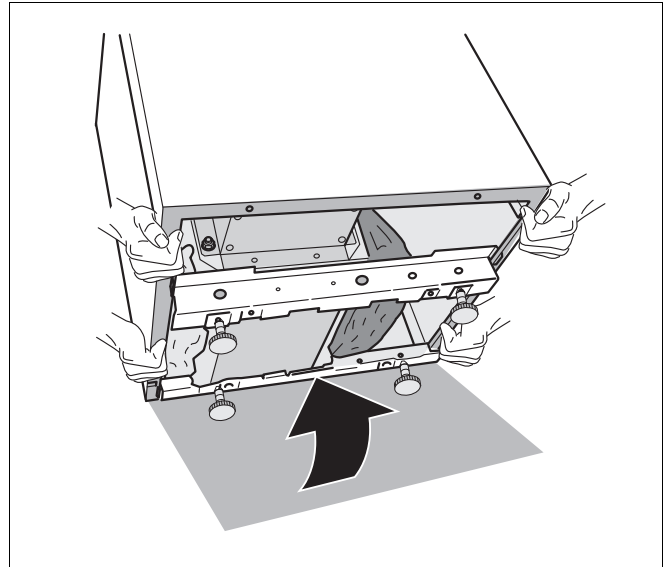

Fig. 8 Unscrewing screw-in feet

7 Boiler installation

This chapter describes how to install the boiler. This includes the following tasks:

- Connecting the heating system
- Electrical connection
- Fuel supply connection
- Installation of flue system

7.1 Preparing for installation

- Unpack all boxes and containers and check all parts against the packing lists to make sure that everything has been supplied.



USER NOTE

Every boiler is carefully inspected and tested before it leaves the factory. However, if you discover any damage or missing parts, please inform the supplier immediately. Before disposing of packing material, make sure that no parts are still in it.

7.2 Heating circuit connection



CAUTION!

BOILER DAMAGE

through moisture.

- Protect the components of the gas ignition system from moisture (dripping, spray, rain) during installation of the boiler, during operation and during maintenance work (such as replacing the pump, replacing the control, etc.).



CAUTION!

SYSTEM DAMAGE

due to overheating as a result of low water.

- Note that a boiler installed above the level of the heating system must be fitted with a low-water alarm. The low-water alarm must be installed during installation of the boiler (→ Fig. 9).



CAUTION!

SYSTEM DAMAGE

due to high temperature variations in the heating system.

- If the boiler is operated in connection with a refrigeration system, make sure that the pipes for the refrigerated liquid are connected in parallel to the boiler system with suitable valves to prevent the refrigerated liquid from entering the boiler.
- The pipe system of a boiler connected to the heating coils of hot-air heating systems that may be exposed to the circulation of cooled air must be fitted with a flow-control valve or some other automatic system for preventing the boiler water from circulating by gravity during the cooling cycle.

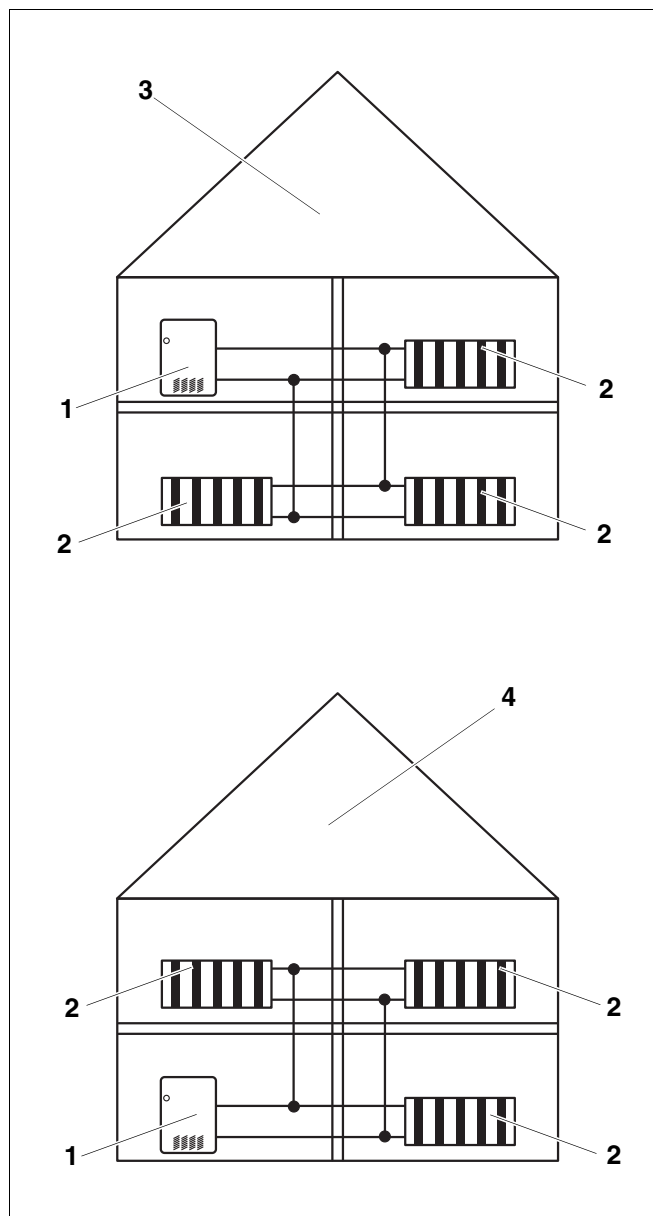

Fig. 9 Low-water alarm

- 1 Boiler
- 2 Radiator
- 3 Heating system with low-water alarm
- 4 Heating system without low-water alarm

Installation of B-kit

The relief valve and the pressure/temperature gauge are mounted on the boiler supply VK over the supply manifold (included in B-kit).

- Seal 90° 1" NPT elbow on VK.
- Seal supply manifold on 90° 1" NPT elbow. The supply manifold can be mounted vertically or rotated 90° to the right.
- Seal temperature/pressure gauge on supply manifold.

**USER NOTE**

Install the relief valve after the leak test (→ Chapter 7.6, page 29).

The relief valve must be installed in a vertical position.

The relief valve must also be installed in accordance with the requirements of the ANSI/ASME Boiler and Pressure Vessel Code, Section IV.

**USER NOTE**

We recommend installing a dirt filter (optional) in the heater return connection to reduce build-up of debris on the water side.

**USER NOTE**

Observe the local regulations for connection of boiler systems.

**CAUTION!****FIRE DANGER**

due to heat.

- Note that a minimum clearance of two inches is required between pipes carrying hot water and flammable walls in the boiler room.

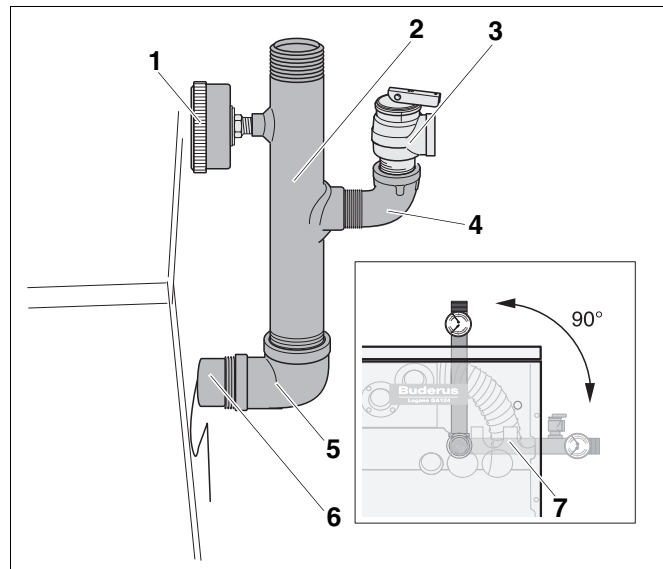

Fig. 10 Installation of B-kit

- 1** Pressure/temperature gauge
- 2** Supply manifold
- 3** Relief valve 3/4"
- 4** 90° 3/4" elbow
- 5** 90° 1" NPT elbow
- 6** Boiler supply VK
- 7** B-kit rotated 90° right

7.3 Electrical connection

The electrical connections of the boiler must be manufactured as specified by the local codes and the current regulations of the National Electrical Code, ANSI/NFPA-70.

In Canada the regulations of CSA C 22.1 Canadian Electrical Code, Part 1, must be observed.

The boiler must be grounded as specified by the regulations of the relevant local authorities; otherwise follow the regulations of the National Electrical Code, ANSI/NFPA-70.



USER NOTE

When making the electrical connections follow the circuit diagrams on → page 58 to page 83.

Install an ON/OFF switch near the boiler.



WARNING!

RISK TO LIFE

from electric shock.

- When conducting maintenance work label all cables before disconnecting them.
 - If cables are connected incorrectly the system may not operate correctly with possibly dangerous consequences.
-
- Check that the heating system functions correctly after any maintenance work.

7.4 Fuel supply connection

7.4.1 Gas connections

For the gas pipe diameter required for the installation please see Tab. 4 and Tab. 5. Make sure that the pipe fitting has the correct thread size.

Make sure that a sediment trap is installed at the inlet for the gas supply pipe to the boiler. A gas shut-off must be installed outside the boiler jacket if required by the local code. We recommend installing a gas shut-off in the main gas pipe to the boiler. The gas pipes must be fastened outside the boiler.

The local codes must be observed during installation of the gas connection, otherwise the regulations of the National Fuel Gas Code, ANSI Z 223.1.



WARNING!

DANGER OF EXPLOSION

Leakage from the gas pipes and gas connections may cause an explosion.

- Use soap solution to find leaks.

Length of pipe in feet	Gas pipe supply volume in cubic feet of gas per hour ¹				
	1/2	3/4	1	1 1/4	1 1/2
10	132	278	520	1060	1600
20	92	190	350	730	1100
30	73	152	285	590	890
40	63	130	245	500	760
50	56	115	215	440	670
75	45	93	175	360	545
100	38	79	160	305	480
150	31	64	120	250	380

Tab. 4 Gas pipe supply volume

¹ Maximum gas supply volume in cubic feet per hour, based on a specific gas weight of 0.60 and a gas pressure of 0.5 psi or less and a pressure gradient corresponding to a water column of 0.3 inches.

Nominal diameter of iron pipe (inches)	Equivalent lengths for pipe fittings in feet			
	Pipe fitting type			
	90° angle	T-piece	Stop valve	Gas valve
Equivalent lengths in feet				
1/2	1.4	2.7	0.3	0.80
3/4	2.1	4.1	0.5	1.25
1	2.6	5.2	0.6	1.6
1 1/4	3.5	6.9	0.8	2.15
1 1/2	4.0	8.0	0.9	2.50

Tab. 5 Equivalent lengths for pipe fittings

Disconnect the boiler with the gas shut-off from the gas supply pipe system the system is pressure tested with a test pressure greater than 1/2 psi.

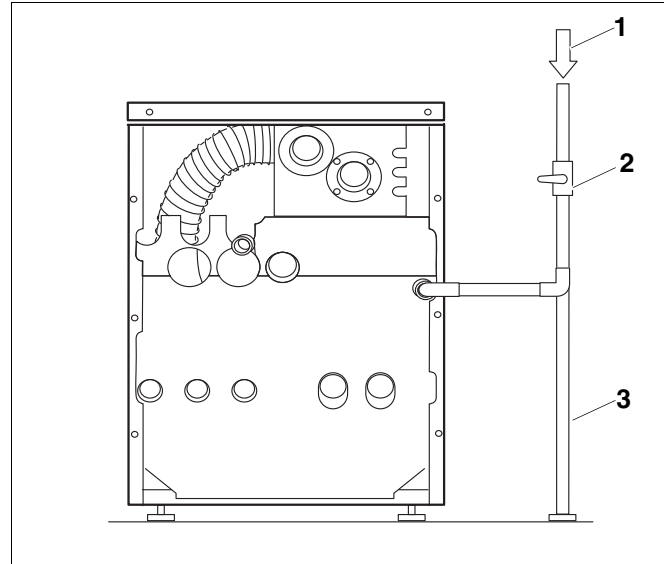

Fig. 11 Pipe connection to gas fittings – back view

- 1 Gas feed
- 2 Hand stop valve
- 3 Sediment trap

If the gas supply pipe system is pressure tested at a test pressure of 1/2 psi or less, it is sufficient to disconnect the boiler from the pipe system by closing the stop valve.

- The boiler and its gas connections must be tested for leaks before placing it into operation, (→ Chapter 9.1, page 33).

Use only sealant that is resistant to corrosion by LPG for pipe connection. Only a small amount of sealant must be applied to the external thread of the pipe connections.

If you wish to convert the boiler to propane, please contact Buderus for the required conversion components. Do not attempt to convert the boiler without the approved Buderus parts and the relevant technical documentation. The technical documentation is included with the conversion parts.

7.4.2 Installation at high altitudes

The boiler is designed for installation at altitudes below 8500 feet above sea level. The boiler must be restricted appropriately for installation above altitudes of 8500 feet. The conversion consists of replacing the main gas orifices.



USER NOTE

If the installation location is over 8500 feet above sea level, please contact Buderus for the required conversion components.

Do not attempt to convert the boiler without the approved Buderus parts and the relevant technical documentation.

The technical documentation is included with the conversion parts (accessories).

7.5 Installation of flue system

The boiler system as delivered includes the wall connection for horizontal flue systems.

Flue systems from the following manufacturers can be installed for the flue and combustion air lines:

Manufacturer	Flue pipe 3"	
	horizontal	vertical*
	Type	Type
heat fab	SAF-T vent	SAF-T vent
O-flex-L	Star 34	-
Pro Tech	FasNSeal	-
Z-Flex	Z-Flex, model SVE	-

Tab. 6 Manufacturer of flue pipe

* The roof penetration is not included with the boiler



USER NOTE

You must follow all directions for installation of the flue venting in all parts of the flue system, particularly the assembly instructions of the flue system manufacturer. Use only pipes with a diameter of 3" for the flue pipes and accessories from the manufacturer named in Tab. 6.

Use rigid or flexible metallic pipes with a diameter of 3" for the combustion line.

The flue system components can be ordered as accessories from your wholesaler or from other suppliers of accessories.



CAUTION!

OPERATING FAULTS

due to strong winds.

If a t-piece is not installed at the end of the flue line, the boiler may stop operating in a storm.

- Note that a termination tee must always be installed at the end of the flue line.
- The termination tee can be purchased from the selected flue line manufacturer.



USER NOTE

Consult the local building and fire inspection authority for any restrictions and inspections of heating systems. Comply with the national regulations.

**USER NOTE**

Note that pipes of different maximum lengths are allowable depending on the size of the boiler and the flue system. The maximum possible lengths are listed in → Tab. 7 - Tab. 11 on → page 28 and → page 29.

7.5.1 Installation of the wall penetration of a horizontal flue systems

Please read the following instructions and information on the installation of the wall penetration carefully and note the safety instructions.

The wall penetration must be installed in the wall as directed by the regulations and/or local building codes.

- Make an opening in the wall with a diameter of six (6) inches at the required position of the wall penetration.
- Insert the wall penetration into the wall from the outside and attach to the outside wall with the four screws.

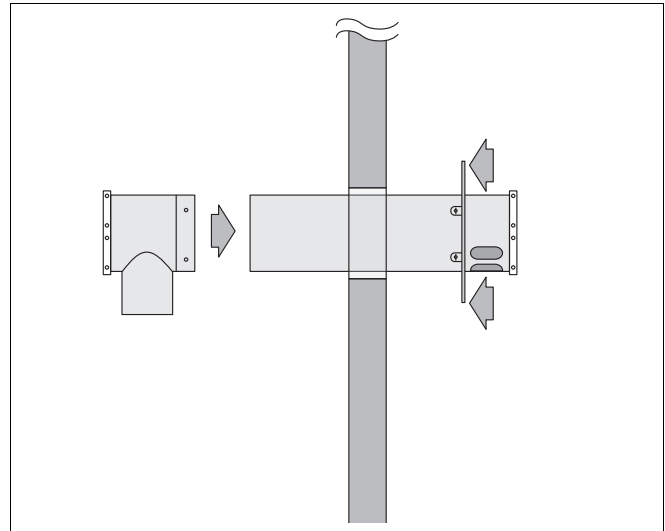

Fig. 12 Wall penetration

- Insert flue pipe into wall penetration from the outside. Attach the termination tee horizontally to the flue pipe and install as directed by the installation instructions of the flue system manufacturer.

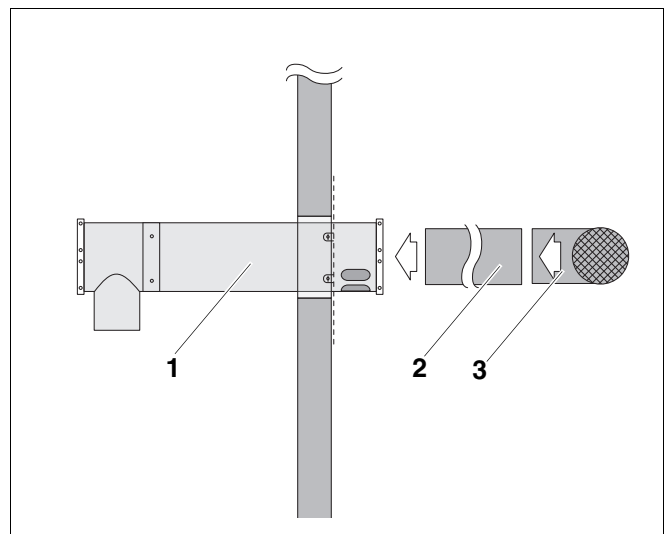

Fig. 13 Installing flue pipe

- 1 Wall penetration
- 2 Flue pipe
- 3 End piece of flue pipe (t-piece)

- Install flue pipe in the wall penetration so the termination tee on the flue pipe extends 10 inches beyond the front edge of the wall penetration..
- Attach the flue pipe to the wall penetration with the two securing clips. Rotate the securing clips down and attach with the screws (→ Fig. 15).
- Seal gap (→ Fig. 15) with silicone.

Make sure that the flue system termination tee through the side wall of a building is at least 12 inches above the ground.

The flue system termination tee must be installed on all heating systems to ensure proper operation and to prevent foreign bodies from entering the flue system.

The termination tee must be at least 12 inches above the expected snow level in areas with heavy snowfall.

No changes are permitted to the wall penetration or any other parts of the flue system. All parts must be installed in original condition.

The flue system must end no less than seven (7) feet above a sidewalk or pedestrian passage.

Make sure that the termination tee is at least six (6) feet away from the combustion air intake of another unit.

The flue system must be installed more than three (3) feet away from any other opening in the building.

Terminating gas meters, controls etc.

The flue system must terminate at least four (4) feet below, four (4) feet horizontally or one (1) foot above every door, every window or every air vent of a building.

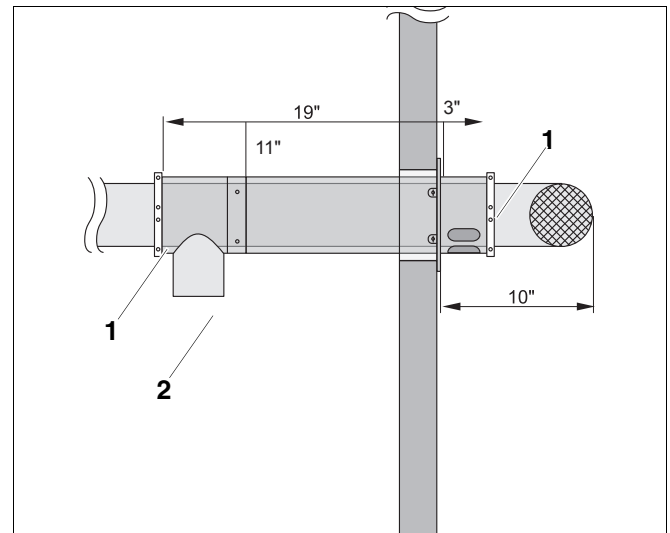

Fig. 14 Position of termination tee on the flue pipe

1 Securing clips

2 3" connection for combustion air pipe

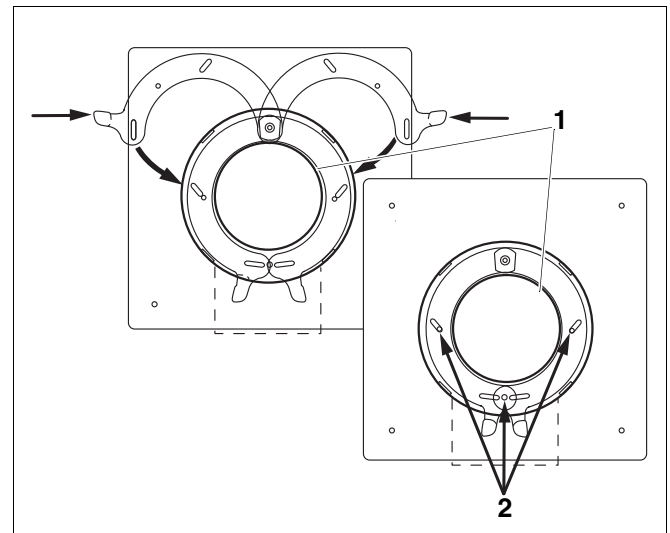

Fig. 15 Securing clips

1 Seal gap with silicone.

2 Screws

Clearance to combustibles for stainless steel vent pipe

clearance enclosed		clearance unenclosed	
horizontal 8"	vertical 4"	horizontal 1"	vertical 1"

7.5.2 Installation of the wall penetration of a vertical flue systems

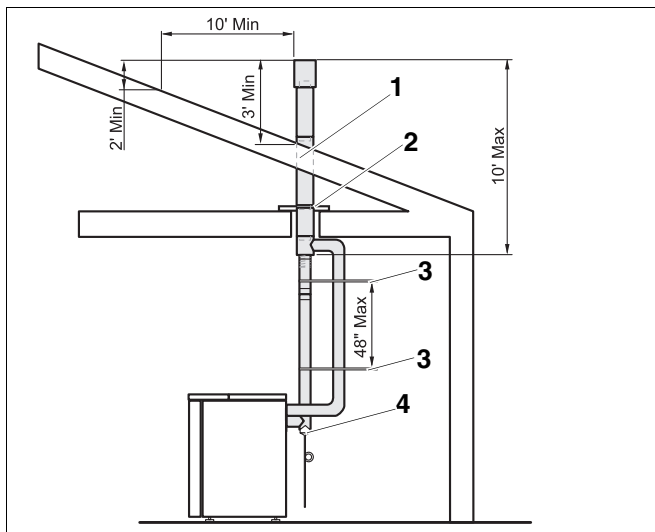

Fig. 16 Vertical flue system

- 1 Roof penetration
- 2 Fire protection ring
- 3 Fastening the flue pipe
- 4 Condensation trap

**USER NOTE**

The vertical flue system requires the flue pipe and concentric pipe with roof penetration from Heat-fab, SAF-T vent. Please contact Buderus to select the required flue system components.

When calculating the extended pipe length for adjustment of the combustion air baffle (→ Chapter 7.5.4, page 27) the length of the concentric pipe must also be taken into account. The condensation trap need not be considered in the calculation.

Fire protection collars (→ Fig. 16) may need to be installed in existing ceiling penetrations.

You must follow the directions for installation of the flue venting in all parts of the flue system, particularly the assembly instructions of the flue system manufacturer.

The combustion air is supplied through a concentric 5" pipe in the vertical flue system. The typical installation of a vertical system is shown in → Fig. 16.

**USER NOTE**

A condensation trap must always be installed at the flue vent.

Note the clearances of the roof penetration above the roof as shown in → Fig. 16.

The maximum length of the concentric combustion air pipe is 10 feet (cf. → Fig. 16).

Note the maximum length of the complete flue system including the concentric pipe as shown in → Tab. 10 and → Tab. 11, (→ page 29).

Clearance from flammable building components is not required near the concentric pipe penetration. A clearance of two (2) inches from flammable building components is required in the area of flue pipe to the concentric pipe.

7.5.3 Installation of the flue and combustion air pipe

Installation of the flue pipe (→ Fig. 18) at the boiler

- Install condensation trap.



USER NOTE

A condensation trap must always be installed at the flue vent.

- Position silicone strip approx. 1/4" wide on the boiler intake (500 ° F-resistant silicone, use G. E. 106 or similar).
- Attach condensation trap to boiler connection (see arrow) and secure with the included hose clamp.
- Place a strip of silicone around the connection point and smooth it to form a gas-tight connection.

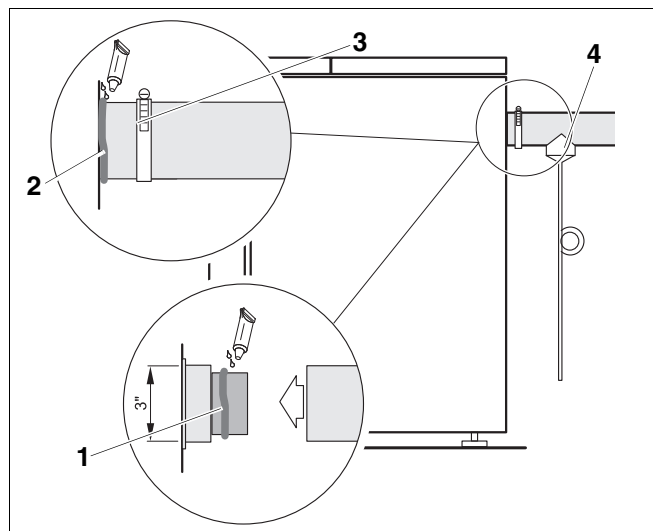

Fig. 17 Condensation trap

- 1 Silicone strip
- 2 Silicone strip
- 3 Hose clamp
- 4 Condensation trap

Installation of the combustion air pipe at the boiler

Proceed as described above for the flue pipe to install the combustion air pipe. A condensation trap is not installed on the combustion air line.

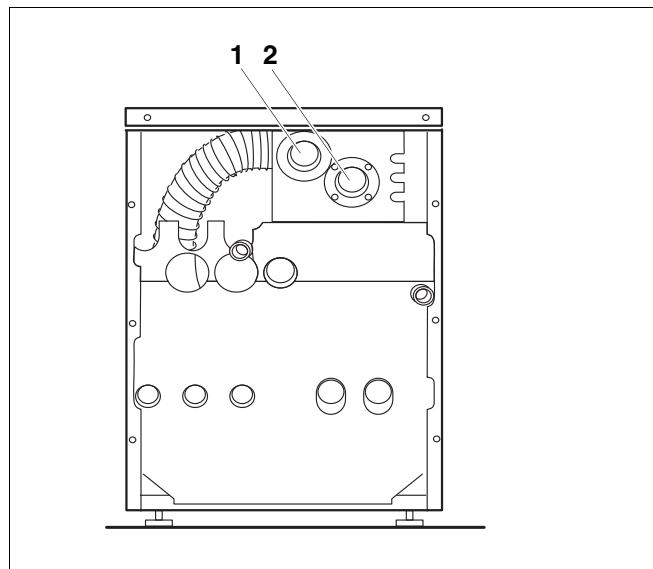

Fig. 18 Back view

- 1 Combustion air line connection
- 2 Flue gas line

**RISK TO LIFE**

by poisoning by leaking flue gas.

WARNING!

- Connect the flue system to one boiler only.
- Connection of another boiler may cause serious injury or death.
- The flue pipes must not be routed into another vent. In addition, the pipes of the flue system must not be routed through another vent or inside another vent, such as with an existing brick or factory-manufactured chimney lining.

**FIRE DANGER**

due to insufficient clearance between flue pipe and flammable building components.

WARNING!

- Make sure that there is a minimum clearance of two (2) inches to flammable building components.
- No minimum clearance is required between the wall penetration and flammable building components.

The vent pipe must be securely fastened. Vertical venting pipes must be fixed with a fire protection collar at every ceiling penetration and fixed with at least one retainer at the base of vertical pipe.

The flue system pipes must be fixed with retainer bands along their length in the vicinity of all elbows and connections and at intervals of at least 48 inches.

When installing fastening components do not drill holes into any of the components of the flue system when joining pipes or fittings or when installing retainer bands. If pipe lengths are cut to size, the cut edges must be filed or ground smooth before joining them. The coupling end of the pipe must not be cut.

Make sure that all horizontal venting pipes have a slope of at least 1/4 inch per foot. All horizontal venting pipes must have a downward slope to the boiler to prevent any accumulations of moisture in the flue system.

The flue system is under overpressure. Silicone sealant must be left to dry for 24 hours before putting the boiler into operation.

**RISK TO LIFE**

by poisoning by leaking flue gas.

WARNING!

- After carrying out one of the above installation instructions always check that all connections in the complete flue system are correctly joined and sealed.
- Check the seams and joints for leaks.
- Have the complete flue system checked by a technician once a year.

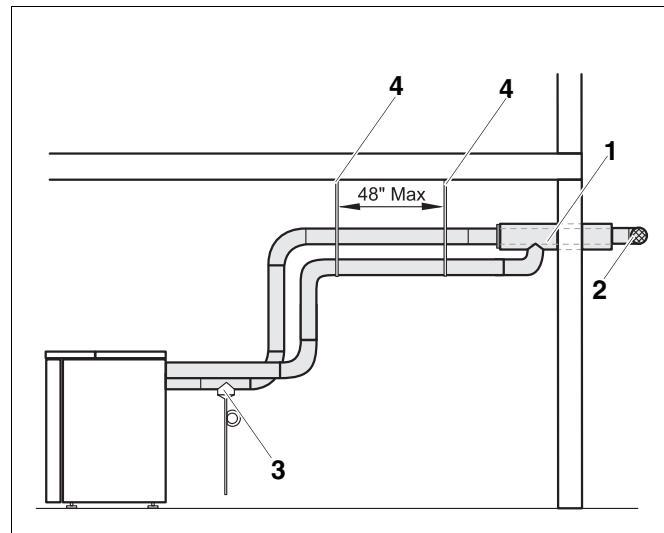

Fig. 19 Horizontal flue system

- 1 Wall penetration
- 2 End piece of flue pipe (termination tee)
- 3 Condensation trap
- 4 Fastening the flue pipe

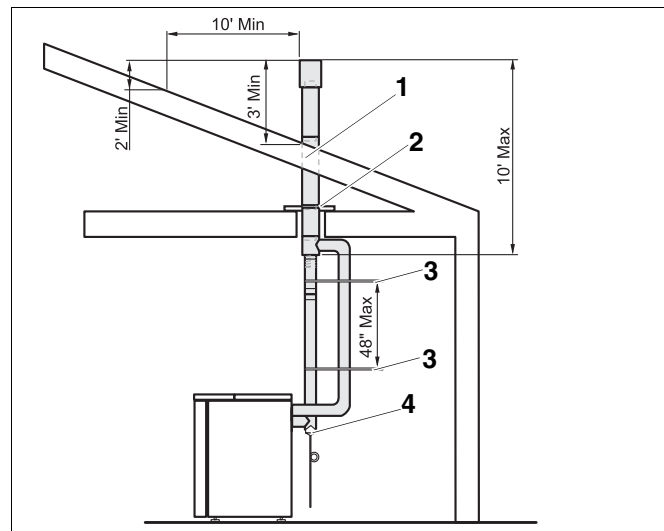

Fig. 20 Vertical flue system

- 1 Roof penetration
- 2 Fire protection collar
- 3 Fastening the flue pipe
- 4 Condensation drain

7.5.4 Adjusting the combustion air baffle

Note the following when calculating the total flue pipe length or combustion air pipe length.

- 1 x 90° elbow corresponds to 10 ft of pipe.
- 2 x 45° elbows correspond to 10 ft of pipe.
- If the combustion air pipe is longer than the flue pipe, the combustion air baffle is adjusted depending on the total length of the combustion air pipe.



USER NOTE

It is not necessary to consider the condensation trap, the wall penetration and the termination tee when calculating the total pipe length.

Determining the combustion air baffle position

- Unscrew cover of blower enclosure.
- Calculate the extended length of the flue pipe or the combustion air pipe by adding the individual sections.
- Calculate the adjustment dimension X of the combustion air baffle with the extended pipe length in Table 7-12.
- Compare the setting of the combustion air baffle and correct if necessary.

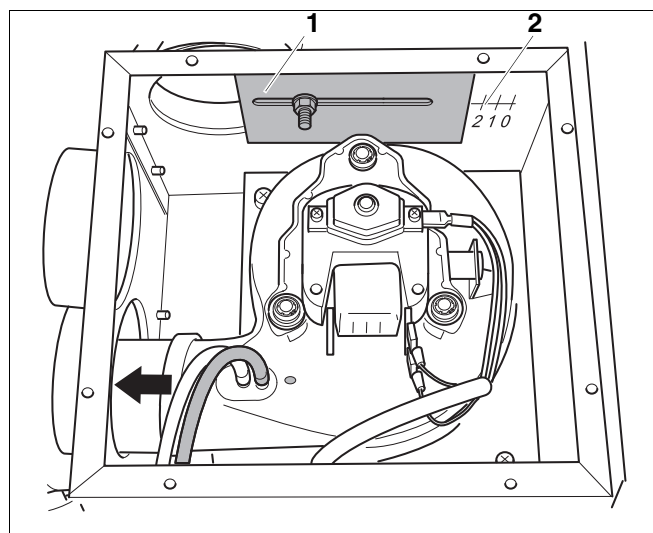

Fig. 21 Adjusting the combustion air baffle

- 1 Combustion air baffle
- 2 Adjustment dimension X

Adjustment for horizontal flue system independent of room air

Combustion air supply through combustion air pipe or flexible combustion air hose from outside.

Boiler size	Adjustment dimension X of the combustion air baffle depending on the length (feet) of the horizontal flue pipe/combustion air pipe				
	up to 12 feet	up to 20 feet	up to 30 cm	up to 40 feet	up to max. feet
30	5.0	4.5	3.5	0	0 (up to 42 feet)
23	5.0	5.0	4.5	4.0	4.0 (up to 50 feet)
17	5.0	5.0	4.5	4.5	4.0 (up to 50 feet)

Tab. 7 Rigid combustion air pipe 3" as per Fig. 22.

Boiler size	Adjustment dimension X of the combustion air baffle depending on the length (feet) of the horizontal flue pipe/combustion air hose
30	0 (up to 20 feet maximum)
23	4.0 (up to 20 feet maximum)
17	4.0 (up to 30 feet maximum)

Tab. 8 Flexible combustion air hose 3" as per Fig. 22

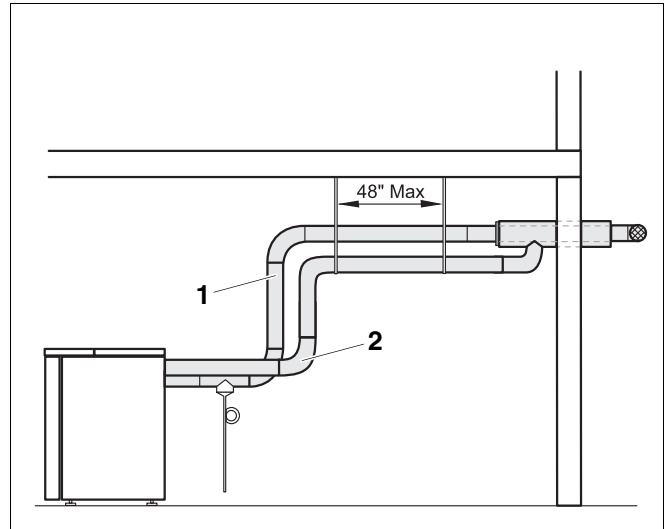

Fig. 22 Horizontal flue system independent of room air

1 Flue pipe 3"

2 Combustion air pipe 3" or combustion air hose 3"

7.5.5 Adjustment for horizontal flue system using room air

Combustion air supply from the boiler room.

Boiler size	Adjustment dimension X of the combustion air baffle depending on the length (feet) of the horizontal flue pipe				
	up to 12 feet	up to 12 feet	up to 30 feet	up to 40 feet	up to max. feet
30	5.5	5.0	5.0	5.0	5.0 (up to 42 feet)
23	5.5	5.5	5.0	5.0	5.0 (up to 50 feet)
17	5.5	5.5	5.0	5.0	5.0 (up to 50 feet)

Tab. 9 Horizontal flue system using room air as per Fig. 23

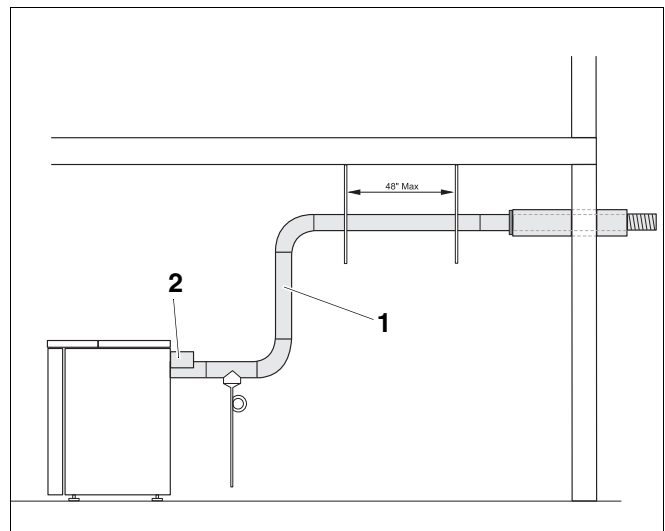

Fig. 23 Horizontal flue system using room air

1 Flue pipe 3"

2 Combustion air inlet from the room

Adjustment for vertical flue system independent of room air

Combustion air supply through combustion air pipe or flexible combustion air hose from outside.

Boiler size	Adjustment dimension X of the combustion air baffle depending on the length (feet) of the vertical flue pipe/combustion air pipe			
	up to 5 feet	up to 30 feet	up to 45 feet	up to max. 50 feet
30	4.5	3.5	0	-
23	4.5	4.0	2.5	2.5
17	4.5	4.0	3.0	3.0

Tab. 10 Rigid combustion air pipe 3" as per Fig. 24

Boiler size	Adjustment dimension X of the combustion air baffle depending on the length (feet) of the vertical flue pipe/combustion air hose
30	0 (up to 30 feet maximum)
23	2.0 (up to 30 feet maximum)
17	3.0 (up to 30 feet maximum)

Tab. 11 Flexible combustion air hose 3" as per Fig. 24

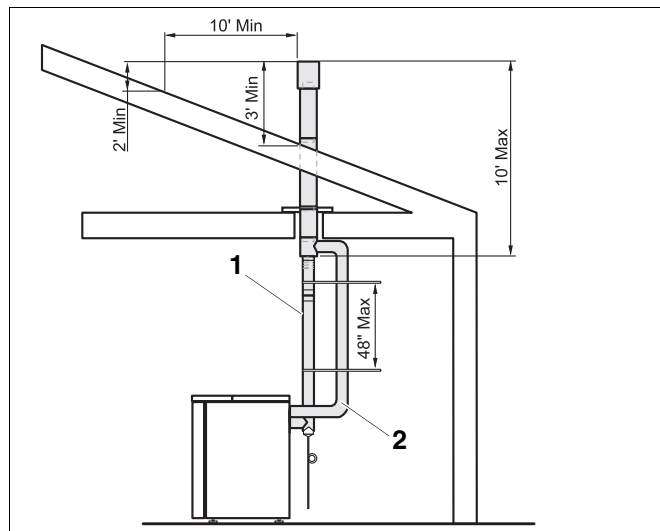

Fig. 24 Vertical flue system independent of room air

- 1 Flue pipe 3"
- 2 Combustion air pipe 3" or combustion air hose 3"

7.6 Filling heating system and checking for leaks

The boiler is tested for leaks at the factory. Before placing the heating system into use, check it for soundness to avoid leaks occurring during operation.

Water treatment



USER NOTE

Have the water analyzed before filling the heating system. The water may require treatment as a result of the analysis.

Please consult the local water supply company if the water is extremely hard or has a pH level below 7.0.



CAUTION!

SYSTEM DAMAGE

due to overpressure during the leak test. Pressure, control or safety components may be damaged by high pressure.

- Before conducting the leak test make sure that no pressure, control or safety components that cannot be disconnected from the water compartment of the boiler are installed.

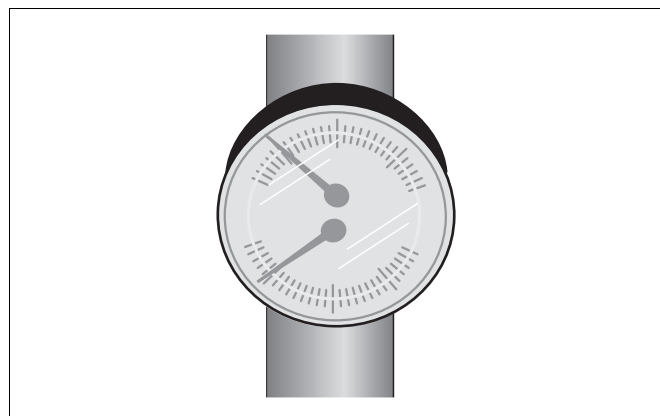

Fig. 25 Temperature/pressure gauge

Carry out the leak test at 1.5 times the normal operating pressure and as specified by the local codes as follows:

Maximum operating pressure	Maximum construction site test pressure
30 psi (with the included relief valve)	45 psi
58 psi (with a different relief valve)	75 psi

Tab. 12 Test pressures

- Close connection for relief valve (→ Fig. 10, page 16) and all other open connections with plugs.
- Disconnect the expansion tank from the system by closing the cap valve.
- Open mixing and stop valves on hot water side.
- Fill boiler slowly with water from the building connection.
- Turn cap of automatic vent one revolution to allow the air to escape.
- Slowly fill heating system. Observe pressure display on pressure gauge during this process.
- Check connections and pipes for leaks.
- Bleed heating system through the bleed valves on the radiators.
- If the pressure falls while bleeding, water must be added.
- Install relief valve (→ Fig. 10, page 16).

8 Openings for combustion air supply and venting



CAUTION!

BOILER DAMAGE AND OPERATING FAULTS

due to missing or inadequate openings for combustion air and venting of the boiler room.

The openings for combustion air supply and venting are always required regardless of whether the combustion air is supplied from the room (operation from room air) or directly to the boiler through ducts (operation independent of room air).

Inadequate venting of the boiler room may result in excessive ambient temperatures. This can damage the boiler.

Inadequate combustion air supply may cause operating faults.

- Make sure that inlets and outlets are not reduced or closed and that they are adequately sized.
- If faults are not corrected immediately, the boiler must not be operated.
- Inform the system operator of the fault and the danger.

To ensure an adequate combustion air supply and venting of the heating system suitable measures must be taken in accordance with the National Fuel Gas Code, Section 5.3, Air for Combustion and Ventilation, or the local codes.

In Canada the regulations in accordance with the CSA/CGA-B 149.1 or 2 Installation Codes apply.



CAUTION!

BOILER DAMAGE

due to contaminated combustion air.

- Never use cleaning agents that contain chlorine and halogenated hydrocarbons (e.g. spray bottles, solvents and cleaning agents, paints, glues).
- Do not store or use these substances in the boiler room.
- Prevent excessive dust levels.



USER NOTE

If contamination of combustion air is possible (e.g. installation near swimming pools, dry cleaners or hair saloons), operation with air outside the room is recommended.



WARNING!

FIRE DANGER

due to flammable materials or liquids.

- Do not store flammable materials or liquids in the immediate vicinity of the heat generator.

Total air supply from inside the building

Make sure that the boiler room has two permanent openings that are connected with one or more other rooms. When calculating the cross-section areas of the openings, the total combustion output of all gas-fired appliances in the connected rooms must be taken into account. Each opening must have a minimum cross-section of one square inch per 1000 Btu/h of the total combustion output of all gas-fired appliances inside the connected rooms. Note that the minimum cross-section of every opening must not be less than 100 square inches. One opening must not be more than 12 inches from the ceiling and the other must not be more than 12 inches from the floor of the boiler room, calculated from the outer edge of the opening. The shortest dimension of all inlet and outlet openings must not be less than three inches.

Total air supply from outside the building

Make sure that the boiler room has two permanent openings, one of which must not be more than 12 inches from the ceiling and the other must not be more than 12 inches from the floor of the boiler room, calculated from the outer edge of the opening. The openings have a direct connection or a connection through ventilation ducts to the outside or to rooms that have an unobstructed connection to the outside (crawl space or attic). The shortest dimension of all inlet and outlet openings must not be less than three inches.

1. If there is a direct connection to the outside, each opening must have a minimum cross-section of one square inch per 4000 Btu/h of the total combustion output of all gas-fired appliances inside the closed room.
2. If there is a connection to the outside through vertical ventilation ducts, each opening must have a minimum cross-section of one square inch per 4000 Btu/h of the total combustion output of all gas-fired appliances inside the closed room.
3. If there is a connection to the outside through horizontal ventilation ducts, each opening must have a minimum cross-section of one square inch per 2000 Btu/h of the total combustion output of all gas-fired appliances inside the closed room.
4. If the openings are connected to ventilation ducts, the ducts must have the same cross-section area as the openings.

9 Placing the heating system in operation

The gas burner and gas fittings unit integrated in the boiler have been tested in the factory as described in detail in ANSI Z 21.13 and CGA 4.9 to ensure safe operation of the heating system and to test specific performance indicators.



WARNING!

RISK TO LIFE

due to electrical current when the unit is open.

- Before opening the unit:
To prevent electrical shock, isolate the heating system with the heating system emergency stop switch or by shutting off the main fuse.
- Lock the heating system to prevent accidental reactivation.

1. Set the room thermostats to the lowest setting.
2. Inspect flue and combustion air piping and the openings for combustion air supply and ventilation.
3. Fill heating system with water and bleed the complete system including the radiators.
4. Unscrew left and right screws in the side panels, lift front panel up, pull down and remove to the front.

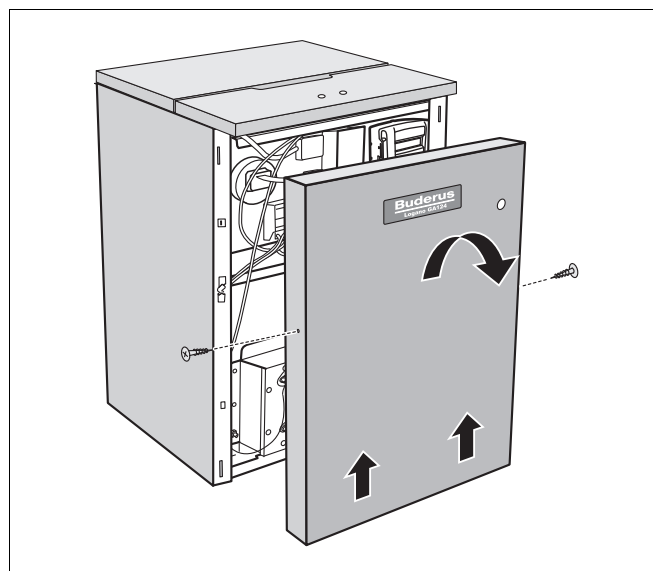

Fig. 26 Removing front panel of boiler

Carrying out leak test

5. Open gas valve in the gas line.
6. Check the gas connection line to the gas fitting (→ Fig. 27) for leaks with soap solution. If no leaks are found, continue with step 8. If any leaks are found, close gas valve.
7. Seal leaks and repeat step 6.
8. Close main gas shut-off. Remove the screw plug for the gas pressure measuring port on the gas valve. Install pressure measuring nipple and attach a pressure gauge to measure the gas pressure.
9. Remove the screw plug for the orifice pressure measuring port on the gas valve. Install pressure measuring nipple and attach a pressure gauge to measure the manifold pressure.
10. Open gas valve and measure the gas supply pressure of the boiler. The supply pressure must be between 4.7" and 10.5" W.C. for natural gas and between 11" and 13" W.C. for propane gas. If the supply pressure for natural gas is not between 4.7" and 10.5" W.C. and not between 11" and 13" W.C. for propane gas, contact the customer service technician or the gas company.
11. Always follow the start-up instructions on the next page.

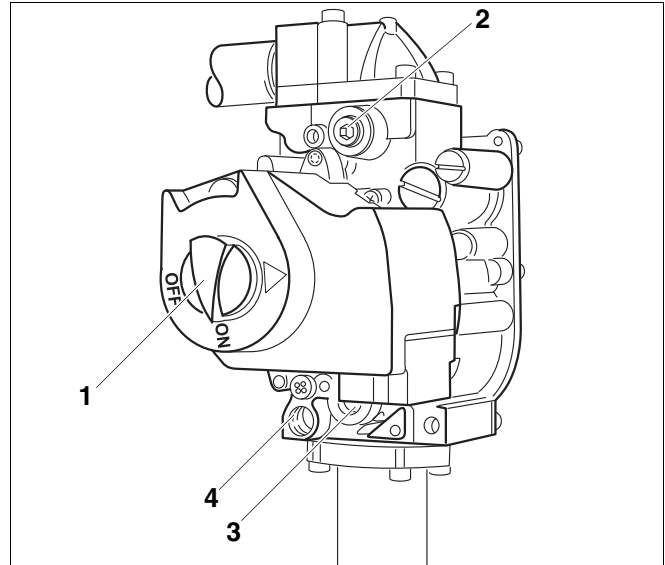

Fig. 27 Gas valve

- 1 ON/OFF button (at ON position)
- 2 Screw plug for gas supply measuring port
- 3 Screw plug for manifold measuring port
- 4 Pilot gas line connection

9.1 Start-up instructions

Read the instructions before start-up for your safety.



WARNING!

RISK TO LIFE

due to not observing the start-up instructions and resulting incorrect operation.

- If these instructions are not followed exactly, a fire or explosion may be caused with serious property damage or loss of life or serious injury.
- Observe the start-up instructions.



WARNING!

DANGER OF EXPLOSION

If you smell gas there is a danger of explosion..

- No open flame. No smoking.
- Prevent spark formation.
Do not operate electrical switches, including telephones, plugs or door bells.
- Shut off main gas supply valve.
- Open doors and windows.
- Warn other occupants of the building.
- Evacuate the building.
- Call gas company, heating service company or fire department from outside the building.

- A** This unit is fitted with an igniter that automatically starts the burner. Do not attempt to ignite it manually.
- B** Check for an odor of gas around the heating system. This test must also be conducted at floor level, because some types of gas are heavier than air and may accumulate at floor level.
- C** Switch on the ON/OFF switch on the gas fitting by hand only. Never use a tool as assistance. If you cannot actuate the ON/OFF switch on the gas fitting by hand, do not attempt to repair it. Contact a qualified technician. Any attempt to use force or to repair the switch may cause a fire or explosion.
- D** Do not operate the unit if any part is under water. Contact a qualified customer service technician immediately to have the unit checked and to replace the parts of the control and gas fittings that were under water.

9.2 Making boiler ready for operation

STOP! First read the safety instructions on → page 33 of this manual.

1. Carry out leak test (→ page 7). Wait five (5) minutes until all gas residues have dissipated. Finally check whether there is any smell of gas, including at floor level. If there is a gas odor: STOP! Follow instructions in section "B" of the safety instructions on → page 33 of this manual. If there is no sign of a gas odor, continue with the next step.
2. Open main gas valve.

Placing heating system with aquasmart control in operation

The boiler is fully functional with the factory-installed aquasmart.

3. Turn on ON/OFF switch (contractor installed) (ON position). This turns on the boiler with all its components. Then continue with step 7.
4. Make sure that the room thermostat signals a heat requirement (set thermostat at least 10 °F above room temperature).

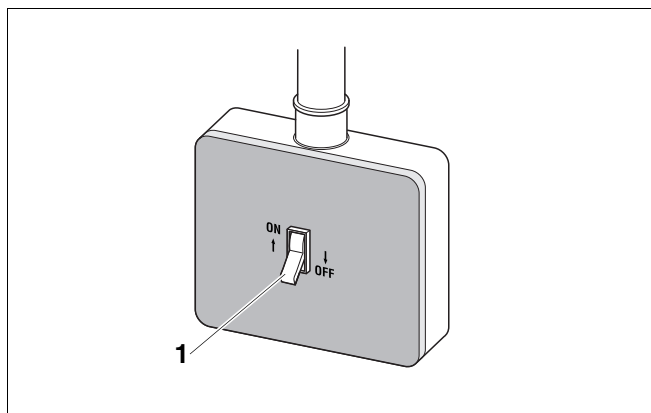

Fig. 28 Switching on heating system (with aquasmart)
1 ON/OFF switch (main switch)

9.3 Then carry out start-up procedures.

The following start-up procedures must be carried out.

5. Look at the igniter through the sight glass in the burner housing.

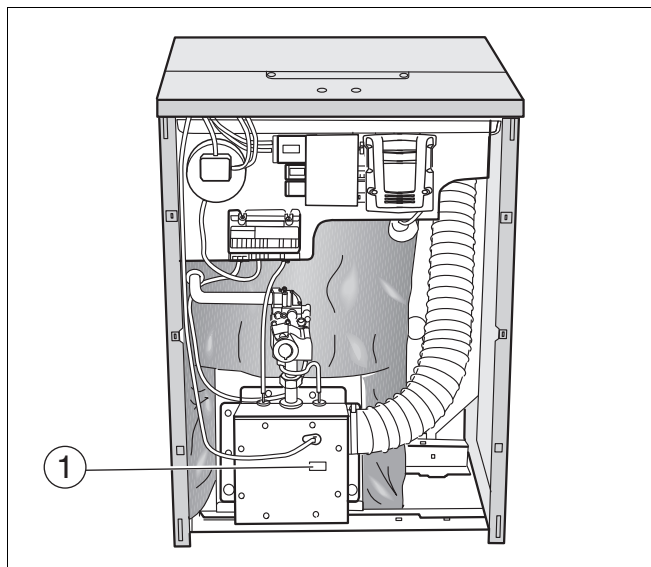

Fig. 29 Front view
1 Sight glass

6. Turn gas valve ON/OFF switch counterclockwise to ON position.
7. The automatic igniter must generate sparks towards the pilot burner. The pilot flame must appear and then ignite the main burner. If the main burner does not ignite, close the gas valve. Disconnect heating system from the power supply and inform your customer service technician or LP gas company.
8. If the main burner has ignited, the gas valve must be checked for leaks with soap solution. If no leaks are found, continue with step 12. If leaks have been found, switch ON/OFF switch on gas valve clockwise to the OFF position. Disconnect heating system from the power supply and set the thermostat to the lowest setting.
9. Seal leaks. Repeat steps 1 and 2.

Caution:

With aquasmart control continue with steps 3 and 4. Then repeat steps 7 to 10 regardless of the control in use.

10. Check the supply gas pressure while the boiler is operating. The supply pressure must be between 4.7" and 10.5" W.C. for natural gas and between 11" and 13" W.C. for propane gas. Record the measured values in the commissioning protocol in the installation and maintenance instructions.

GA124	Natural gas [inch W.C.]	Propane [inch W.C.]
17	3.6	8.9
23	3.6	9.9
30	3.5	9.5

Tab. 13 Manifold pressure

11. Check manifold pressure. The manifold pressure must be set in accordance with the values in → Tab. 13. To set the manifold pressure the cover (→ Fig. 30) on the gas valve must be removed. Turn the adjustment screw clockwise to increase the pressure and counterclockwise to reduce the pressure. This setting must be adjusted while the boiler is operating.
12. Record the set value in the commissioning protocol of the installation and maintenance instructions and screw the safety screw (→ Fig. 30, page 37) into the gas valve again.

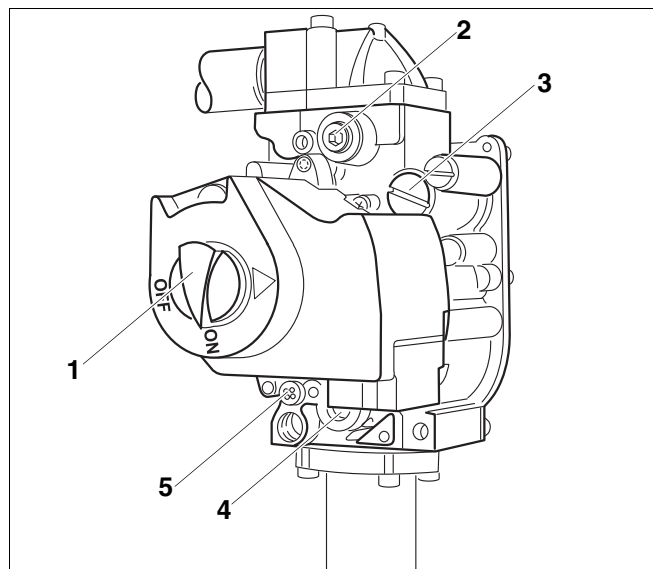

Fig. 30 Gas valve

- 1 ON/OFF button (at ON position)
- 2 Screw plug for gas supply pressure measuring port
- 3 Safety screw for manifold pressure setting
- 4 Screw plug for manifold measuring port
- 5 Safety screw for pilot ignition pressure setting

13. Observe ignition flame through the sight glass (→ Fig. 29, page 36) in the burner housing.
14. The flame must envelope the flame guard 1/2 to 1 1/2 inches. If this is the case continue with step 20.
15. If the ignition flame is too small or too large, the pressure for the pilot burner must be adjusted with the corresponding adjustment screw.



USER NOTE

The adjustment screw is behind the ignition gas pressure adjustment safety screw (→ Fig. 30, page 37).

16. Remove safety screw for pilot ignition pressure setting (→ Fig. 30, page 37). Turn the inner adjustment screw clockwise to reduce the ignition flame and counterclockwise to enlarge the ignition flame.
17. After adjustment tighten the ignition gas pressure adjustment safety screw (→ Fig. 30, page 37) again.
18. Observe main burner flame through the sight glass (→ Fig. 29, page 36) in the burner housing. The flame must have a steady and fixed contour and generally has a bluish color. If the main burner flame meets the requirements, proceed with step 21. If the main burner flame is too weak or is yellow or goes out, turn the ON/OFF switch (→ Fig. 30, page 37) on the gas valve clockwise to OFF. Close the gas valve and disconnect the heating system from the power supply and contact the customer service technician or the gas company.

Checking flame sensor

19. Test the safety switch by closing the gas valve. The main burner flame (→ Fig. 32) and the ignition flame (→ Fig. 31) are extinguished. After six (6) seconds at the most the main gas solenoid valve on the gas valve must close with an audible noise.
20. After 90 seconds the automatic igniter must switch to lock status and stop generating sparks.
21. Disconnect the heating system from the power supply. Open main gas valve. Switch on unit power supply. A normal operating cycle must follow.
22. If the gas valve operates correctly, proceed to step 25. If the gas valve does not operate correctly, switch ON/OFF switch (→ Fig. 33) on the gas valve clockwise to the OFF position immediately. Close main gas valve. Disconnect heating system from the power supply and inform the customer service technician or LP gas company.

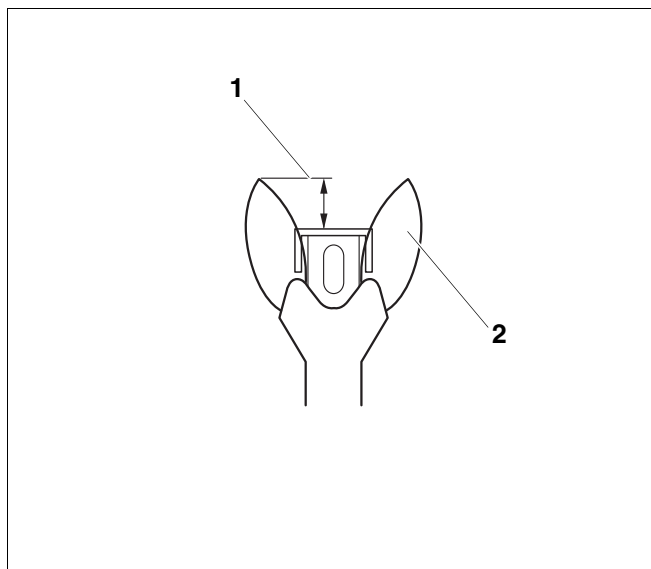

Fig. 31 Correct pilot flame setting

- 1 1/2 to 1 1/2 inches
- 2 Pilot flame

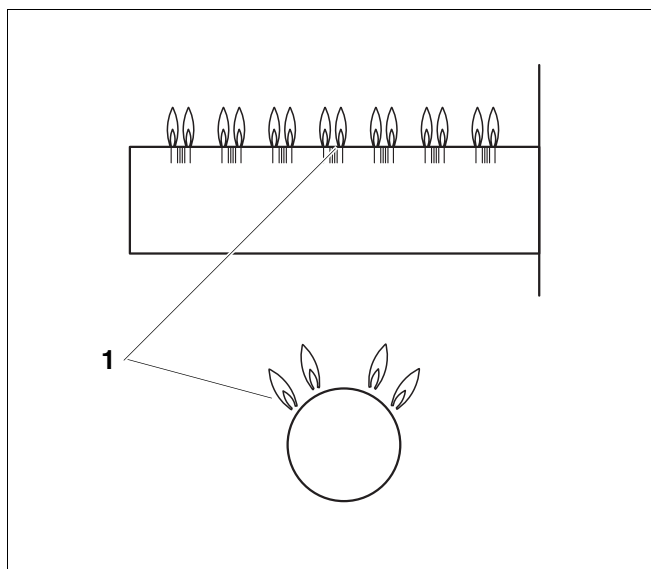

Fig. 32 Main burner

- 1 Main burner flame

23. Turn gas valve ON/OFF button clockwise to OFF position.
24. Close main gas shut-off.
25. Disconnect heating system from the power supply and set the thermostat to the lowest setting.
26. Remove pressure measuring nipple and pressure gauge for measuring gas supply pressure and manifold pressure from the gas valve and close the openings with the screw plugs.
27. Repeat steps 1 to 10 (depending on the control) and 20 to restart the heating system. Check the screw plugs for leaks with soap solution. If no leaks are found, continue with step 31. If leaks are found, close gas shut-off and switch ON/OFF button on gas valve clockwise to the OFF position. Disconnect the heating system from the power supply.
28. Seal leaks. Open gas shut-off and repeat step 24.
29. Carefully wipe away the soap solution to prevent corrosion caused by the alkali content of the soap.
30. Check the function of the maximum aquasmart to make sure that it switches off the boiler as soon as the boiler water temperature set at the aquasmart is reached. Record the result in the commissioning protocol of the installation and maintenance instructions.
31. Replace front panel of boiler.

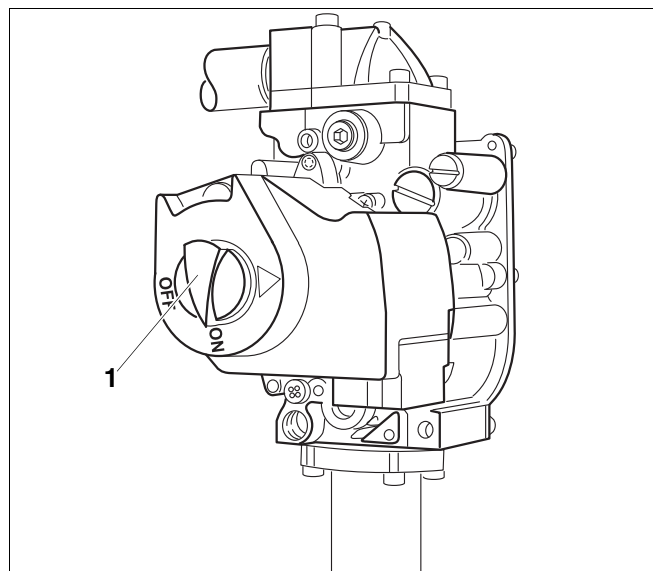

Fig. 33 Gas valve

1 ON/OFF button (at ON position)

9.4 Shutting off gas supply to boiler

1. Set thermostat to the lowest value.
2. Disconnect heating system from the power supply before carrying out maintenance work.
3. Remove front panel of boiler

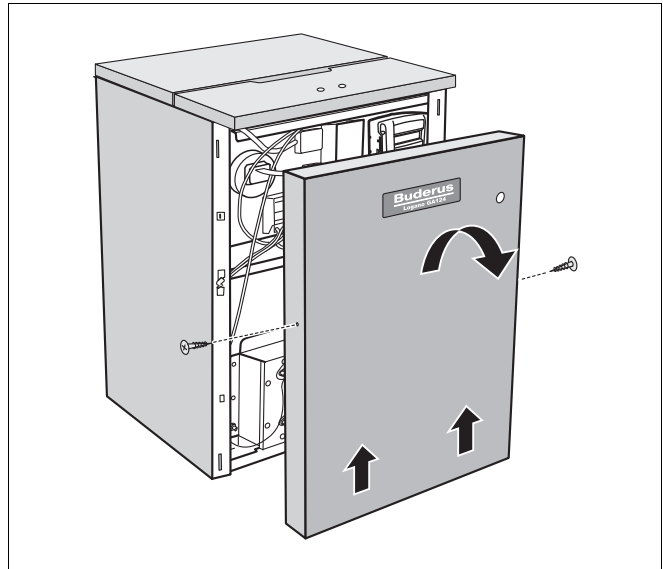

Fig. 34 Remove front panel of boiler

4. Turn gas valve ON/OFF button clockwise to OFF position. Do not use force.
5. Replace front panel of boiler.

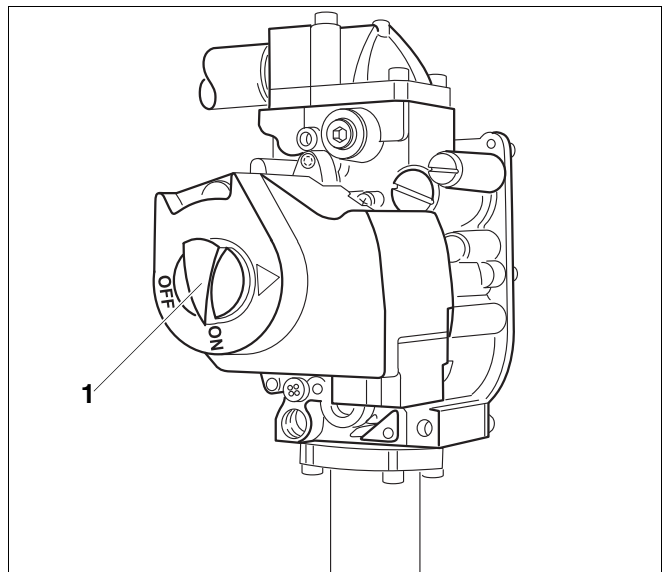

Fig. 35 Gas valve

1 ON/OFF button (at ON position)

9.5 Instruct owner/operator and hand over technical documentation

Inform the owner/operator of the operation of the complete heating system and the operating instructions for the boiler. Together with the owner sign the protocol on page 42 and hand over the technical documentation.



CAUTION!

SYSTEM DAMAGE

due to frost.

The heating system may freeze in frosty conditions if the control is not switched on.

- Protect the heating system from freezing when there is a danger of frost.
- When the main switch or control is switched off, drain the water from the boiler, the tank and the pipes of the heating system.

9.6 Start-up protocol

Please check off the start-up work as it is completed and record the measured values in the table.

Start-up work	Remarks or measured values
1. Type of gas	<input type="checkbox"/> Natural gas <input type="checkbox"/> Propane
2. Check combustion air, inlet and outlet openings and flue gas connection	<input type="checkbox"/>
3. Check the unit fittings (correct orifices?, ✂ Tab. 14 below) and convert gas type if necessary	<input type="checkbox"/>
4. Fill boiler with water and bleed complete heating system	<input type="checkbox"/>
5. Measure gas pressure (supply pressure)	_____ inches W. C.
6. Measure manifold pressure and adjust if necessary	_____ inches W. C.
7. Leak check in operating status, check pilot and main burner flame and correct functioning of the venting system	<input type="checkbox"/>
8. Check maximum aquasmart	<input type="checkbox"/>
9. Install front boiler panel	<input type="checkbox"/>
10. Inform operator, hand over technical documentation	<input type="checkbox"/>
11. Installer: Operator:	Signature: _____ Signature: _____

	Main gas orifice identification		
Boiler size	17	23	30
Natural gas	265	250	250
Propane gas	175	160	160

Tab. 14 Main gas orifice identification



USER NOTE

- Inform the customer of the correct fuel and enter it in the table (→ operating manual of boiler).

10 Taking the boiler out of operation

10.1 Normal boiler shut-down

1. Switch off main switch ("OFF" position). This shuts down the boiler with all components (e.g. burner).
2. Additional shut-down procedure → follow the directions for the AquaSmart.

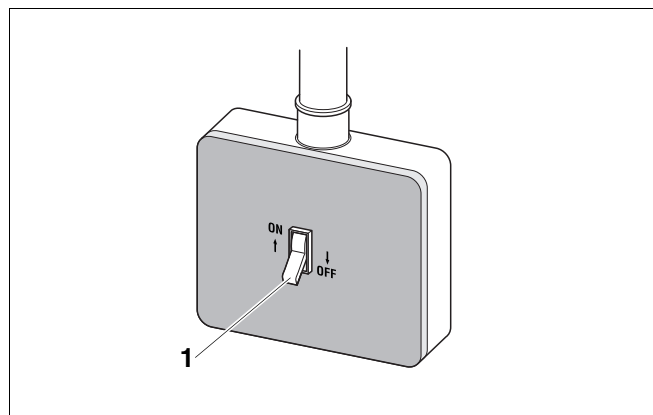

Fig. 36 Shutting down heating system (with AquaSmart)

1 ON/OFF switch

3. Shut off main fuel supply valve.



SYSTEM DAMAGE

through frost.

CAUTION! The heating system can freeze up in cold weather if it is shut down.

- Leave the heating system switched ON constantly as much as possible.
- Protect the heating system from freezing by draining the heater and water pipes at the lowest point.

10.2 Emergency shut-down

Inform your customer of the procedure in case of emergency, such as a fire.

1. Never put yourself at risk. Your own safety must always take priority.
2. Shut off main fuel supply valve.
3. Shut down the heating system with the heater emergency switch or the corresponding circuit-breaker.

11 Boiler inspection and maintenance

11.1 Why is regular maintenance important?

Heating systems require regular maintenance for the following reasons:

- To maintain high efficiency operation and to operate the heating system economically (low fuel consumption).
- To sustain safe operation.
- To maintain combustion at an environmentally friendly level.

All maintenance work must be carried out by a qualified customer service technician only. When replacing components use only parts approved by Buderus. Maintenance is required once a year. Record the results of the inspection in the protocol at → page 55.



USER NOTE

Spare parts can be ordered from your local distributor.

11.2 Testing the flue system, including combustion air, air inlets and Ventilation openings

Check the venting system, including the combustion air, inlet and outlet openings. All faults must be repaired immediately.

Make sure that the combustion air feed and the inlets and outlets are not blocked at any point.

11.3 Inspection of the boiler and burner

1. Visually check the boiler and burner for external dirt.
2. Check burner box, supply air hose and burner rods for dirt.
3. Check air supply hose for damage and replace if necessary.
4. If dirt is found, clean boiler and burner.

11.4 Preparing boiler for cleaning

1. Take the boiler out of operation (→ Chapter 10.1, page 43).



RISK TO LIFE

from electric shock.

WARNING!

- Before opening a unit: disconnect electrical power completely and lock to prevent accidental reconnection.

2. Remove front panel of boiler (→ Fig. 26, page 33).



RISK TO LIFE

from explosion of flammable gases.

WARNING!

- Never work on gas lines unless you are licensed for this type of work..

3. Turn gas valve ON/OFF button clockwise to OFF position. Do not use force.



RISK TO LIFE

from explosion of flammable gases.

WARNING!

- Wait five (5) minutes until all gas residues have dissipated. Check whether there is any smell of gas, including at floor level. If there is a gas odor: STOP! Follow instructions in section "B" of the safety instructions on → page 35 If there is no sign of a gas odor, continue with the next step.

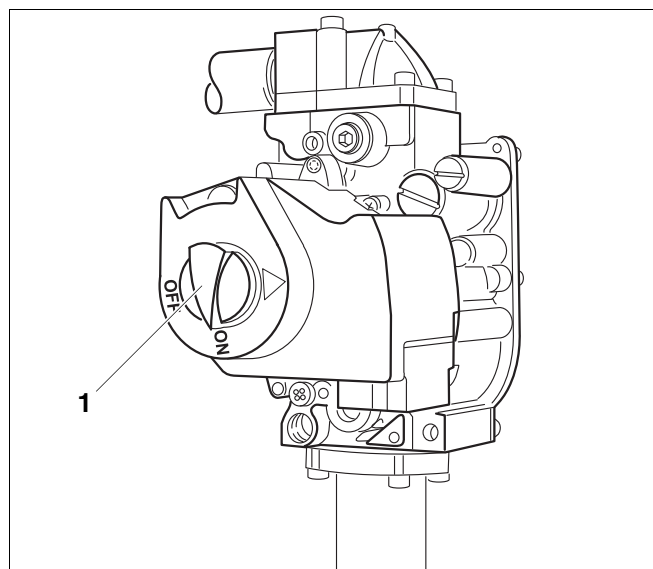

Fig. 37 Gas valve

1 ON/OFF button (at ON position)

11.5 Cleaning the boiler

The boiler can be cleaned with brushes and/or by wet cleaning. Cleaning tools are available as accessories.

11.5.1 Cleaning the boiler with brushes

Remove burner:



WARNING!

RISK TO LIFE

from electric shock.

- Label all electrical wiring before disconnecting it for cleaning the boiler. If cables are connected incorrectly the system may not operate correctly with possibly dangerous consequences.
- After maintenance test the heating system for proper function.



WARNING!

RISK TO LIFE

from electric shock.

- Before opening a unit: disconnect electrical power completely and lock to prevent accidental reconnection.

1. Disconnect your heating system from the mains electricity supply.
2. Shut off main gas supply valve.

3. Disconnect pilot gas line from gas valve.
4. Disconnect ignition cable from ignition module.
5. Attach gas supply line to burner control holder with wire or string.
6. Remove screws (→ Fig. 39) between gas valve and burner box. Place the gas connection pipe gasket in a safe place.
7. Label connection lines of flame roll-out switch and disconnect from the switch.

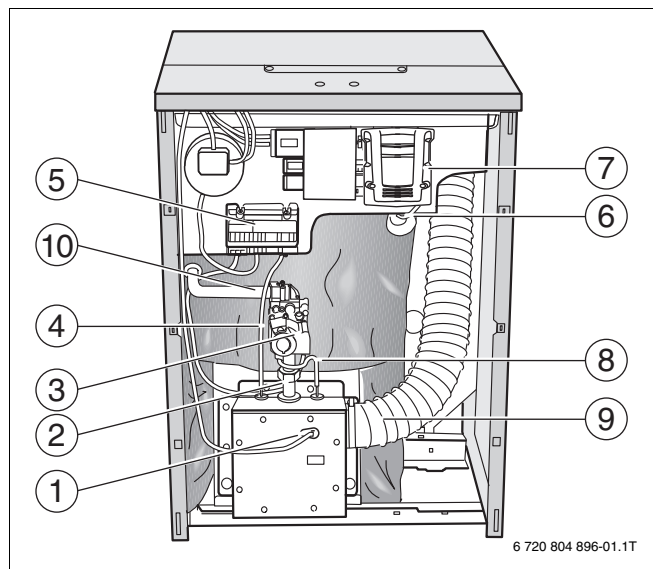

Fig. 38 Front view

- 1 Flame roll-out switch (boiler size 17)
- 2 Gas supply pipe
- 3 Gas valve
- 4 Ignition cable
- 5 Ignition module
- 6 Wire holder for gas supply line
- 7 Burner control
- 8 Ignition gas line
- 9 Air supply hose
- 10 Gas supply line

8. Remove screws in burner box cover and remove cover.
9. Unscrew nuts and remove gas burner with burner box.
10. Release air supply hose (→ Fig. 38) and pull off burner box.
11. If there is dirt in the burner compartment, remove venting fan, otherwise continue with (→ Chapter 11.6, page 50).

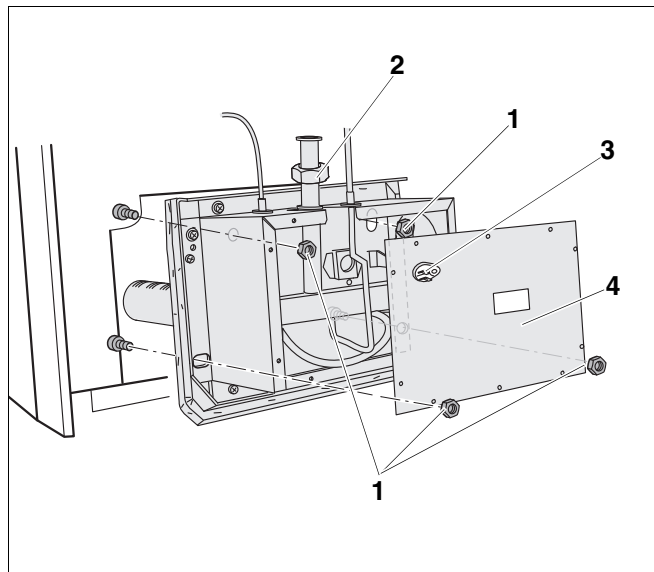

Fig. 39 Removing gas burner

- 1 Fixing nuts
- 2 Screws
- 3 Flame roll-out switch (boiler size 23 and 30)
- 4 Burner box cover

Removing venting fan

12. Remove rear boiler jacket.

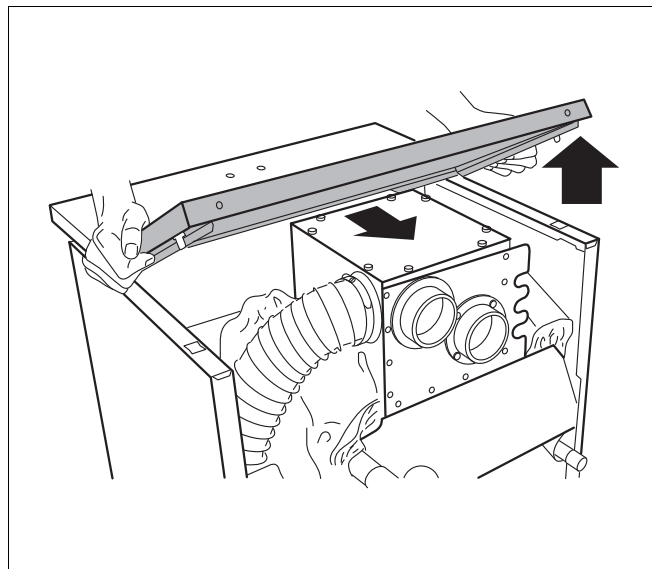

Fig. 40 Removing rear boiler jacket

13. Slide fan manifold into the venting adapter in the direction of the arrow to the stop.

14. Pull off connecting hose for differential pressure connection on measuring points on fan.

15. Disconnect electrical wiring.

16. Unscrew the four screws of the fan retainer panel.

17. Lift fan with retainer panel slightly and remove.

18. Check fan blades for dirt and clean if necessary.

19. If the hot gas ducts are dirty clean boiler.

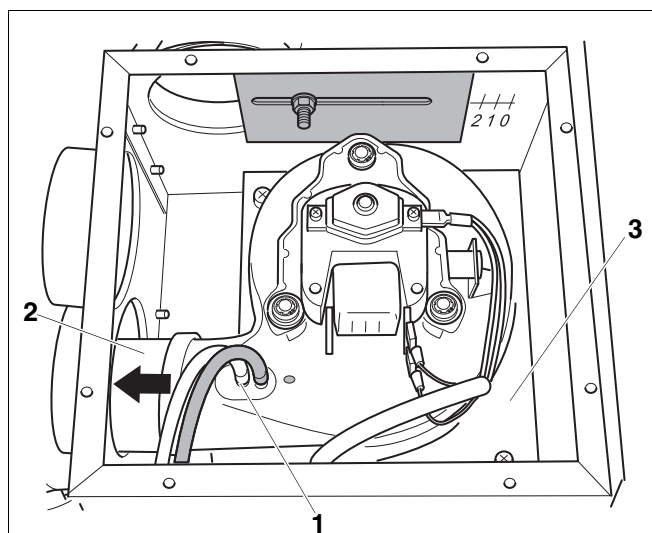

Fig. 41 Removing venting fan

1 Pressure measurement point on fan

2 Fan manifold

3 Fan retainer panel

20. Cover control with foil to prevent entry of metal dust into the control.

21. Use boiler brush to clean out flue gas passages.

22. Clean combustion chamber and bottom insulation.

11.5.2 Wet cleaning (chemical cleaning)

For the wet cleaning use a suitable cleaning agent for the degree of build-up of dirt (soot or scale).

Use the same procedure as described for cleaning with brushes (→ Chapter 11.5.1, page 46).



USER NOTE

Observe the directions for use of the cleaning agent. In some case you may need use a different procedure from that described here.

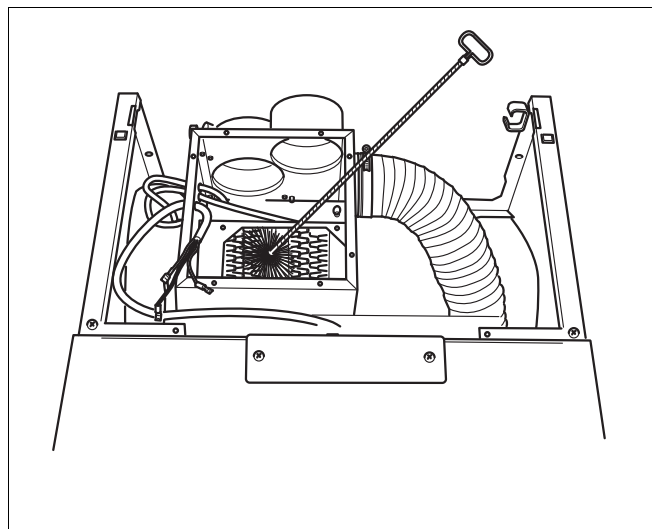

Fig. 42 Cleaning with brushes

23. Cover control with foil to prevent entry of spray into the control.
24. Ventilate boiler room well.
25. Place cloths on the floor insulation to catch excess spray.
26. Spray flue gas vents evenly with the cleaning agent.
27. Assemble and install the burner in reverse order of removal and disassembly (→ page 46). Tighten the fixing nuts well. Make sure that the front edge of the burner box cover is properly engaged in the sealing grommets.
28. Install venting fan in reverse order of removal; see → page 48.
29. The blue connector sleeves on the differential measuring case must be connected to the blue connecting sleeves of the measuring points.
30. Make sure that the fan manifold is completely pushed on to the fan during reassembly.
31. Place the heating system in operation.
32. Heat the boiler water to a temperature of at least 50 °F.
33. Take the boiler out of operation.
34. Allow boiler to cool.
35. Remove burner and venting fan (→ page 46).
36. Brush out flue gas passages.
37. Clean combustion chamber and bottom insulation.
38. Remove cloths.
39. Ventilate boiler room well again.
40. Assemble and install the burner in reverse order of removal and disassembly (→ page 46). Tighten the fixing nuts well. Make sure that the front edge of the burner box cover is properly engaged in the sealing grommets.
41. Install venting fan in reverse order of removal; see → page 48.
42. The blue connector sleeves on the differential measuring case must be connected to the blue connecting sleeves of the measuring points.
43. Make sure that the fan manifold is completely pushed on to the fan during reassembly.

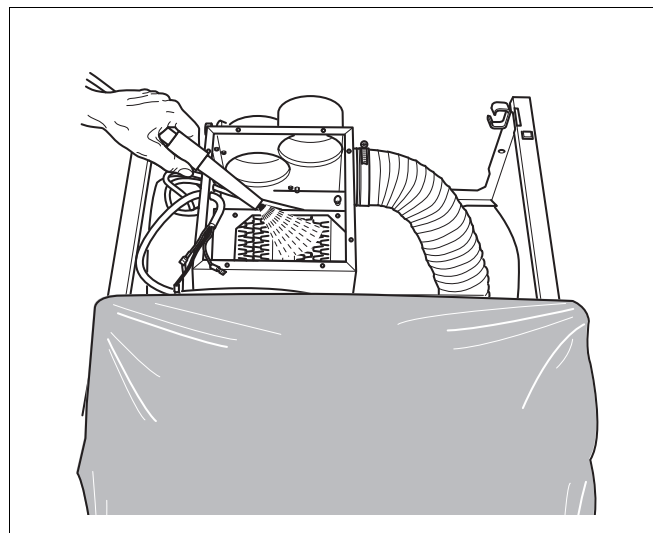

Fig. 43 Spray cleaning

11.6 Cleaning the burner

1. Remove burner (→ page 46).
2. Check burner rods for dirt. If necessary, clean burner as described below.
3. Unscrew pilot burner unit from burner.
4. Disconnect pilot gas line from ignition burner unit.
5. Remove pilot gas orifice and blow out.
6. Immerse burner rods in water with cleaning agent and brush off.



USER NOTE

Make sure that the insulation on the burner shield does not get wet.

7. Rinse out burner rods with a water jet; hold burner so water enters all slots if the burner rods and drains out again.
8. Remove remaining water by swinging the burner.
9. Check that the slots of the burner rods are free. Remove water and dirt residue in the slots. If any slots are damaged the burner must be replaced.
10. Assemble and install the burner in reverse order of removal and disassembly (→ page 46). Tighten the fixing nuts well. Make sure that the front edge of the burner box cover is properly engaged in the sealing grommets.
11. Place boiler in operation as directed in (→ Chapter 9.1, page 33).
12. Check operation of AquaSmart.
13. Test low water cut-off if installed.
14. Check area around boiler for hazards.
The area around the boiler must be free from flammable substances, gasoline or any other flammable or corrosive vapors and liquids.



WARNING!

RISK TO LIFE

from explosion of flammable gases.
After maintenance work leaks may occur in pipes and threaded fastenings.

- Make a thorough check for leaks.
- Use only approved leak testing agents to search for leaks.

Complete the maintenance protocol to confirm that all maintenance work has been conducted. Sign the maintenance protocol and discuss it with the owner of the heating system.

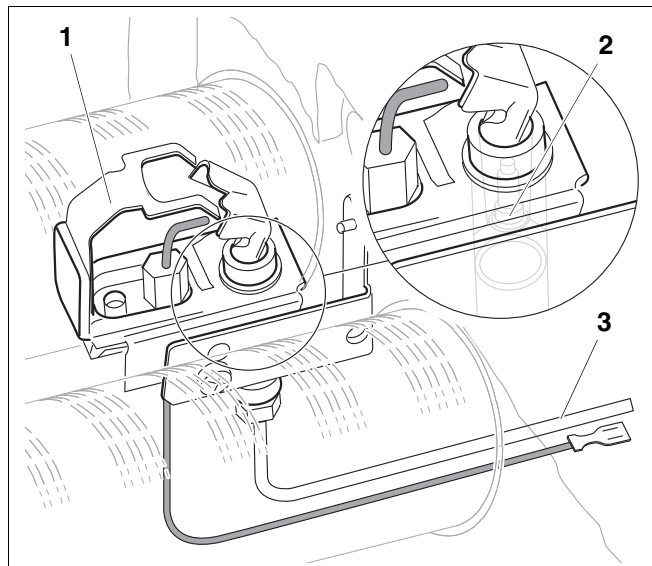
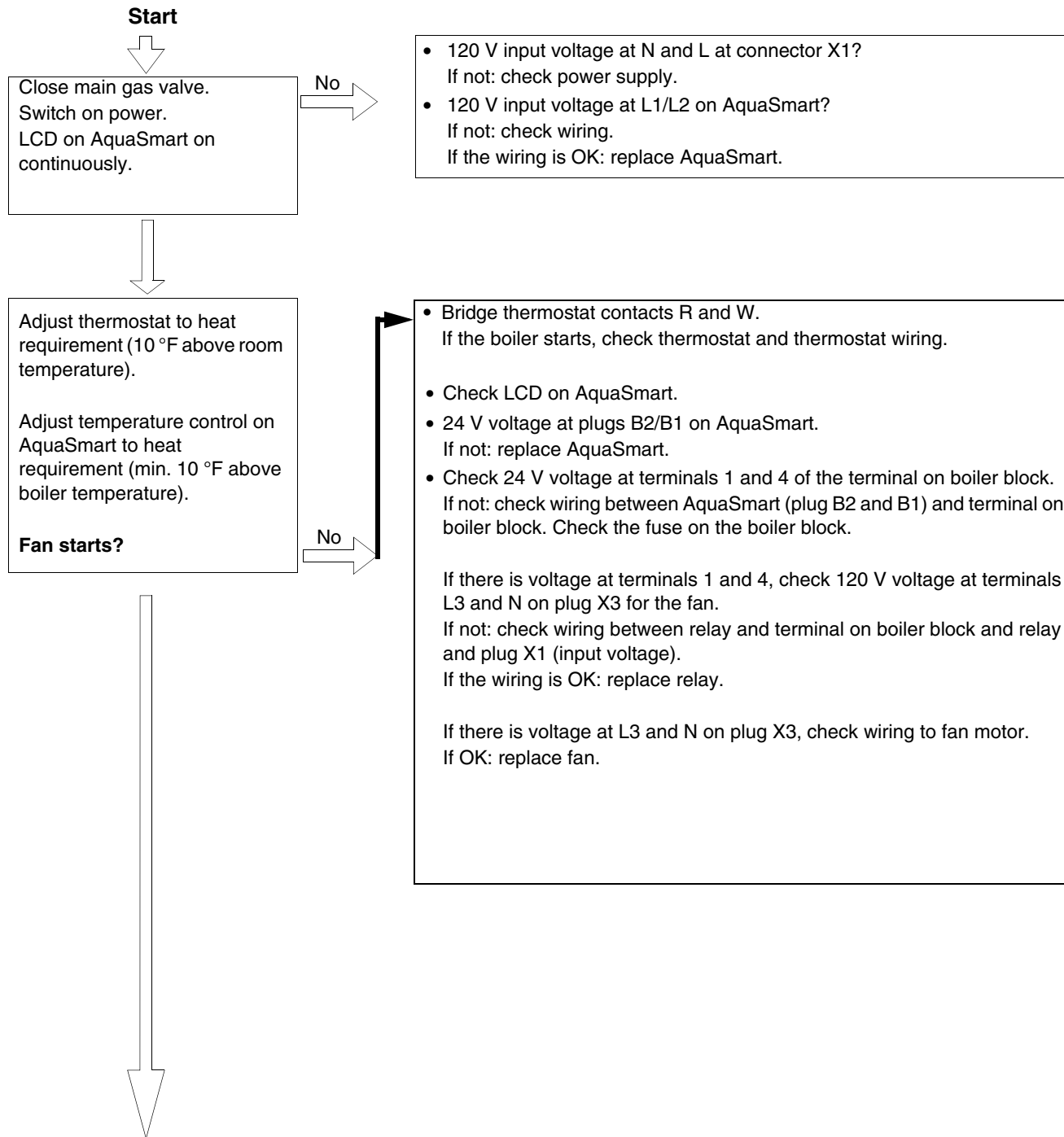

Fig. 44 Pilot burner unit

- 1 Pilot burner unit
- 2 Pilot gas orifice
- 3 Pilot gas line

11.7 Troubleshooting

Equipment required: Wiring diagram page 58 and voltage detectors for 120 VAC and 24 VAC.



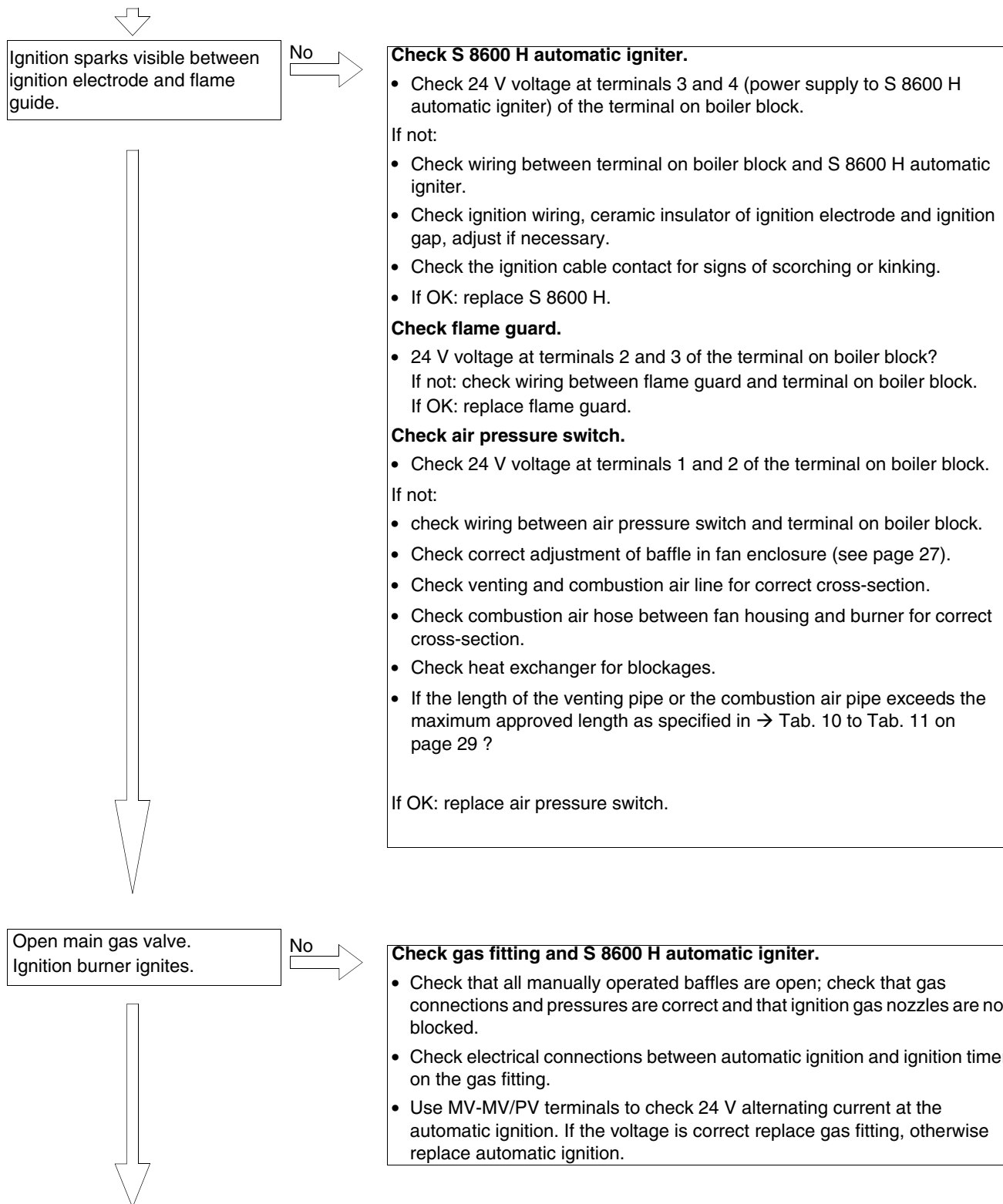

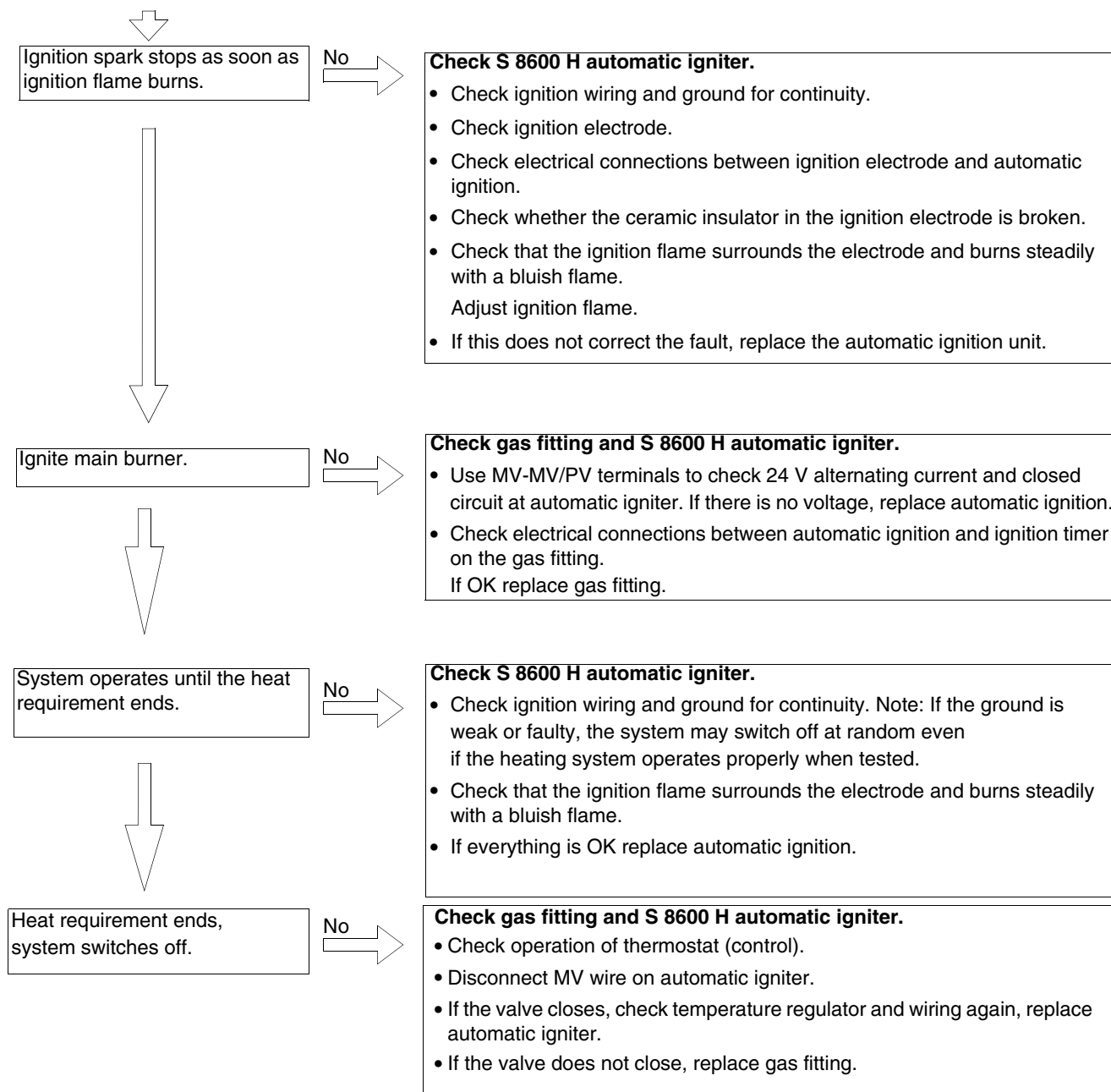

End of troubleshooting

Repeat procedure until heating system operates correctly.

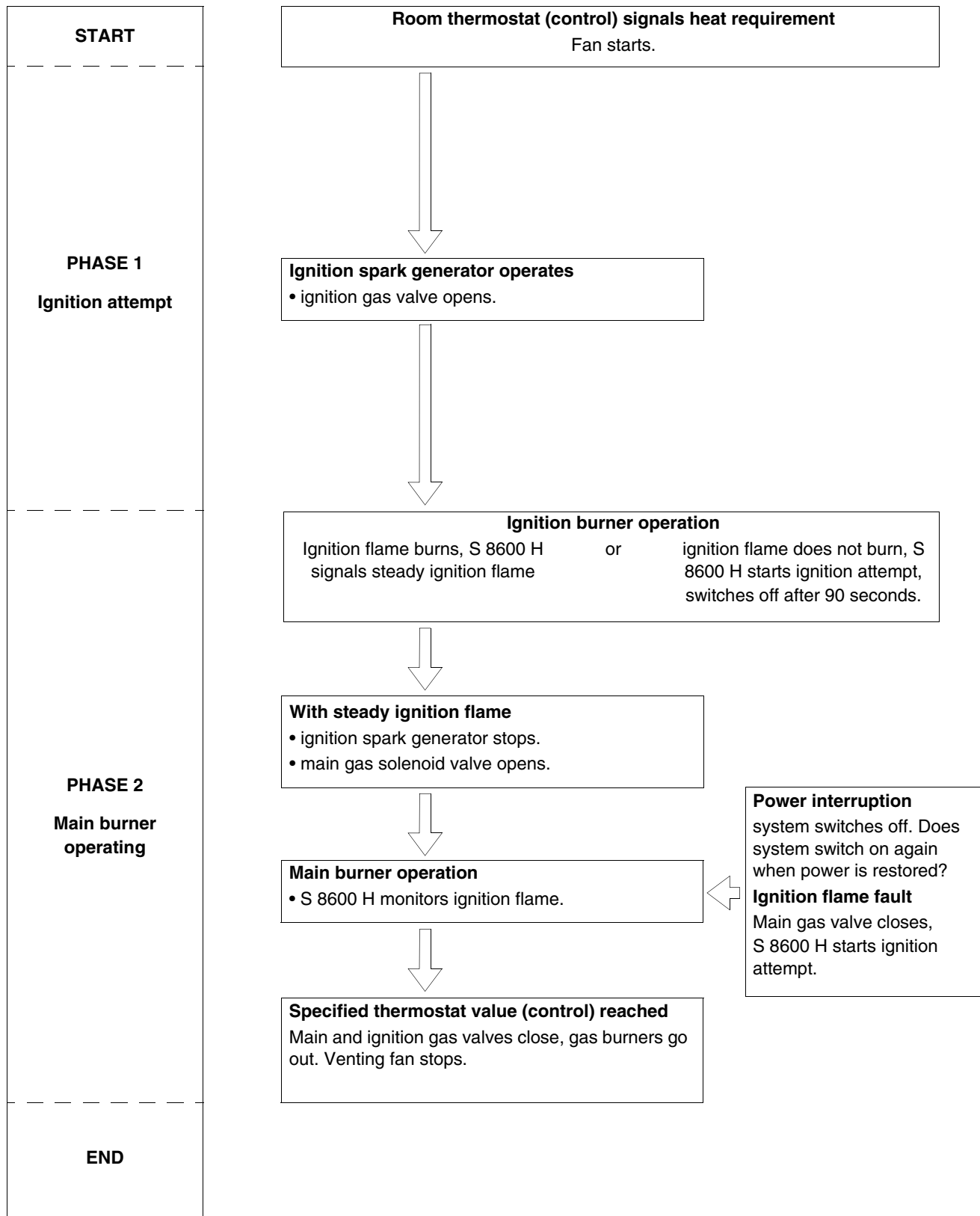

11.8 Maintenance protocol

Please check off the maintenance work as it is completed and record the measured values.
Follow the instructions on the following pages.

Maintenance work	Page	Date:	Date:
1. Inspection of the flue system including combustion air, inlet and outlet openings	page 44	<input type="checkbox"/>	<input type="checkbox"/>
2. Inspection of boiler	page 44	<input type="checkbox"/>	<input type="checkbox"/>
3. Inspection of burner	page 44	<input type="checkbox"/>	<input type="checkbox"/>
4. Cleaning boiler	page 46	<input type="checkbox"/>	<input type="checkbox"/>
5. Cleaning burner	page 50	<input type="checkbox"/>	<input type="checkbox"/>
6. Measuring gas supply pressure	page 34	_____inches W. C.	_____inches W. C.
7. Measuring manifold pressure	page 37	_____inches W. C.	_____inches W. C.
8. Checking for leaks in operating condition	page 34	<input type="checkbox"/>	<input type="checkbox"/>
9. Checking pilot and main burner flame	page 38	<input type="checkbox"/>	<input type="checkbox"/>
10: Check operation of venting fan.		<input type="checkbox"/>	<input type="checkbox"/>
11. Check maximum aquasmart	page 50	<input type="checkbox"/>	<input type="checkbox"/>
12. Check the area around the boiler for flammable materials, gasoline or other corrosive liquids.	page 50	<input type="checkbox"/>	<input type="checkbox"/>
13. Confirm maintenance Confirmation of correct maintenance (company stamp, signature)		<input type="checkbox"/>	<input type="checkbox"/>

Datum:	Datum:	Datum:	Datum:	Datum:
<input type="checkbox"/>	<input type="checkbox"/>	<input type="checkbox"/>	<input type="checkbox"/>	<input type="checkbox"/>
<input type="checkbox"/>	<input type="checkbox"/>	<input type="checkbox"/>	<input type="checkbox"/>	<input type="checkbox"/>
<input type="checkbox"/>	<input type="checkbox"/>	<input type="checkbox"/>	<input type="checkbox"/>	<input type="checkbox"/>
<input type="checkbox"/>	<input type="checkbox"/>	<input type="checkbox"/>	<input type="checkbox"/>	<input type="checkbox"/>
<input type="checkbox"/>	<input type="checkbox"/>	<input type="checkbox"/>	<input type="checkbox"/>	<input type="checkbox"/>
_____ inches W. C	_____ inches W. C	_____ inches W. C	_____ inches W. C	_____ inches W. C
_____ inches W. C	_____ inches W. C	_____ inches W. C	_____ inches W. C	_____ inches W. C
<input type="checkbox"/>	<input type="checkbox"/>	<input type="checkbox"/>	<input type="checkbox"/>	<input type="checkbox"/>
<input type="checkbox"/>	<input type="checkbox"/>	<input type="checkbox"/>	<input type="checkbox"/>	<input type="checkbox"/>
<input type="checkbox"/>	<input type="checkbox"/>	<input type="checkbox"/>	<input type="checkbox"/>	<input type="checkbox"/>
<input type="checkbox"/>	<input type="checkbox"/>	<input type="checkbox"/>	<input type="checkbox"/>	<input type="checkbox"/>
<input type="checkbox"/>	<input type="checkbox"/>	<input type="checkbox"/>	<input type="checkbox"/>	<input type="checkbox"/>
<input type="checkbox"/>	<input type="checkbox"/>	<input type="checkbox"/>	<input type="checkbox"/>	<input type="checkbox"/>
<input type="checkbox"/>	<input type="checkbox"/>	<input type="checkbox"/>	<input type="checkbox"/>	<input type="checkbox"/>

12 Specifications

Main gas orifice identification and rated orifice pressure for natural gas

Boiler size	Number of nozzles	Main gas orifice identification for altitudes [feet]		Rated manifold pressure [in. W.C.]
		0–8500 ft ¹⁾	8501–12000 ft ²⁾	
17	2	265	260	3.6
23	3	250	245	3.6
30	4	250	245	3.5

Tab. 15 Main gas orifice identification and rated manifold pressure for natural gas

Main gas orifice identification and rated orifice pressure for LP gas

Boiler size	Number of orifices	Main gas orifice identification for altitudes [feet]		Rated manifold pressure [in. W.C.]
		0–8500 ft ²⁾	8501–12000 ft ²⁾	
17	2	175	170	8.9
23	3	160	155	9.9
30	4	160	155	9.5

Tab. 16 Main gas orifice identification and rated manifold pressure for LP gas

1) factory setting

2) use conversion parts only as directed by the technical documentation



USER NOTE

If the installation location is over 8500 feet above sea level, please contact Buderus for the required conversion components.

Do not attempt to convert the boiler without the approved Buderus parts and the relevant technical documentation.

The technical documentation is included with the conversion parts (accessories).

13 Wiring diagrams

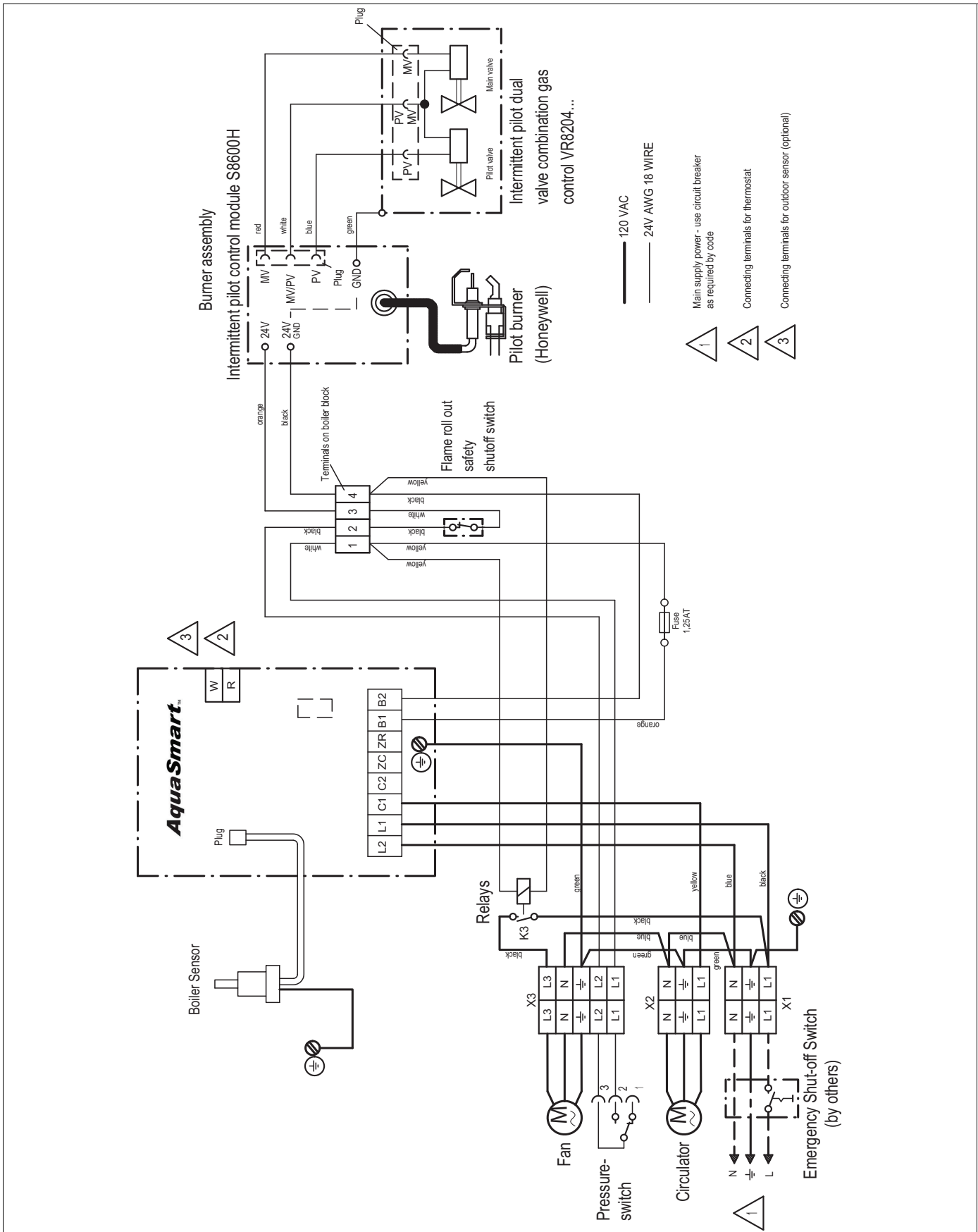

Fig. 45 Wiring diagram – Model GA124

Wiring Schematic GA 124

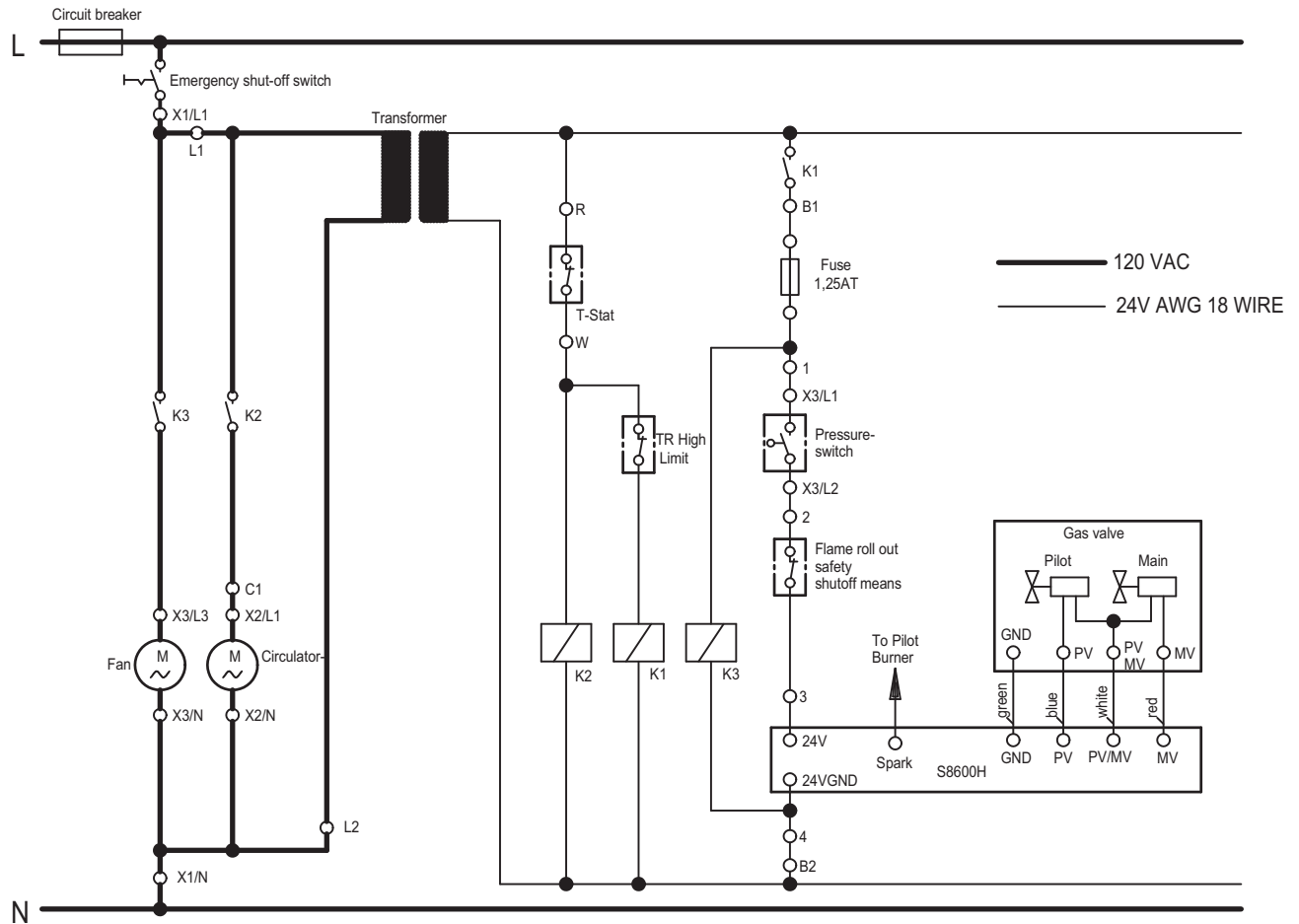

Fig. 46 Wiring diagram – Model GA124

Bosch Thermotechnology Corp.
50 Wentworth Avenue
Londonderry, NH 03053
Tel. 603-552-1100
Fax 603-965-7581
www.buderus.us

Products manufactured by
Bosch Thermotechnik GmbH
D-35576 Wetzlar
Sophienstrasse 30-32
www.buderus.com

Bosch Thermotechnology Corp. reserves the right
to make changes without notice due to continuing
engineering and technological advances.

Buderus