

Installation and maintenance instructions

Oil and gas-fired boilers Logano G215 US



Buderus

1	Safety Considerations	5
1.1	With respect to this manual	5
1.2	Application Purpose.	5
1.3	Guideline of Notice	5
1.4	Please observe these notes	5
1.4.1	If you notice a smell of gas.	5
1.4.2	Installation tips	5
1.4.3	Tips for the boiler room.	6
1.5	Tools, materials and equipment	6
1.6	Disposal	6
2	Product Description	7
3	Technical information.	8
3.1	Technical data for boiler without burner.	8
3.2	Operating conditions	9
3.2.1	General operating requirements	10
3.2.2	Boiler room and environmental conditions	10
3.2.3	Combustion air supply conditions	11
3.2.4	Fuel conditions	11
3.2.5	Power supply conditions	11
3.2.6	Hydraulic conditions and water quality	12
4	Packaging and Components	13
5	Moving the boiler	14
6	Placing the Boiler.	15
6.1	Clearances.	15
7	Boiler block assembly	16
7.1	Assembly when delivered in sections	17
7.1.1	Preparing boiler sections.	17
7.1.2	Preparing push nipples and nipple ports	18
7.1.3	Preparing the intermediate section.	18
7.1.4	Inserting the section sealing	19
7.1.5	Knock intermediate section into place	19
7.1.6	Boiler section alignment	20
7.1.7	Join boiler sections by the nipples at the top and bottom boiler hub.	20
7.1.8	Fitting the anchor rods	23
7.1.9	Fitting distribution tube and supply/return header	23
7.1.10	Sealing the sensor well.	24
7.1.11	Positioning the flue outlet	25
7.1.12	Sealing boiler hubs.	25
7.2	Check for leaks	26
7.2.1	Preparing for a leak test	26
7.2.2	Leak test	26
7.3	Installation when boiler is supplied assembled	27
7.4	Installation steps for disassembled and assembled delivery	27
7.4.1	Fitting adjustable feet	27
7.4.2	Insert the flue gas baffle plates.	28
7.4.3	Installing the burner door.	28
7.4.4	Fitting the boiler jacket	29
7.5	Positioning and leveling the boiler.	33

8	Boiler installation	34
8.1	Flue connection	34
8.1.1	Chimney venting	34
8.2	Installation of water connections	36
8.2.1	Installing B-Kit:	36
8.2.2	Installation of boiler drain (included in B-Kit)	36
8.2.3	Installation of system components	37
8.3	Filling heating system and checking for water leaks	37
8.4	Burner installation	38
8.5	Providing a fuel supply	39
8.6	AquaSmart™ installation	39
8.7	HydroStat installation	40
8.8	Electrical connections	40
8.8.1	Fitting the Logamatic control panel	40
8.8.2	Installation of the temperature sensor set and burner cable	41
8.8.3	Electrical connections and connection of additional components	43
8.8.4	Strain relief installation	43
8.9	Jacket panel installation	43
9	Placing the boiler in operation	44
9.1	Setting the operating pressure	44
9.2	Check pressure relief valve	44
9.3	Making the heating system operational	45
9.4	Starting up the control and the burner	45
9.5	Guidelines for starting up the burner	45
9.6	Raising flue gas temperature	46
9.6.1	Removing flue gas baffle plates	46
9.6.2	Removing the blocking plate	47
9.7	Checking the high Limit cut-out (STB)	47
9.8	Installing jacket panels	47
9.9	Start-up protocol	48
10	Taking the boiler out of operation	49
10.1	Normal boiler shut-down	49
10.2	Emergency shut-down	49
11	Boiler maintenance	50
11.1	Why is regular maintenance important?	50
11.2	Preparing the boiler for cleaning	50
11.3	Boiler cleaning	51
11.3.1	Cleaning the boiler with cleaning brushes	51
11.3.2	Wet cleaning (chemical cleaning)	52
11.4	Checking the heating system operating pressure	53
11.5	Testing relief valve	53
11.6	Inspection and maintenance protocols	54

Table of Content

12 Troubleshooting 57

13 Examples of installations 58

14 Circuit diagrams 60

1 Safety Considerations

1.1 With respect to this manual

This installation and maintenance manual contains important information for the safe and correct installation, initial start-up and maintenance of this boiler.

The oil and gas fired boiler Logano G125 mit Brenner Logatop BE is generally referred to below as a boiler.

The installation and maintenance manual is provided for technicians who have been trained and have experience in working with heating systems and oil and gas fired installations.

1.2 Application Purpose

The boiler can only be used for hot water space heating and water heating for single and multi family homes.

Please note the details on the rating plate and the specifications to ensure the correct use of this equipment.

1.3 Guideline of Notice

The following symbols are used in this manual:

 **WARNING!** **DANGER TO LIFE**
Identifies possible risks that may lead to serious injury or death if appropriate care is not taken.

 **CAUTION!** **DANGER OF INJURY/ SYSTEM DAMAGE**
Identifies a possible dangerous situation that can lead to mild to moderate personal injury or physical damage.

 **NOTICE**
Tip for optimum use of equipment and adjustment as well as useful information.

è Cross references

Cross references to a specific section or another document are identified with an arrow.

1.4 Please observe these notes

Observe all local codes and standards during installation and operation:

- Local building code regulations regarding installation, combustion air supply and flue gas systems as well as connection to a chimney.
- Electrical code requirements for connection to the power supply.
- The technical rules of the gas supply company regarding the connection of a gas burner to the gas system.
- Regulations and standards regarding safety equipment of the heating system.

 **NOTICE**
Use only original Buderus components. Losses caused by the use of parts not supplied by Buderus are excluded from the Buderus warranty.

1.4.1 If you notice a smell of gas

 **WARNING!** **DANGER TO LIFE**
through the explosion of volatile gases. If you can smell gas there is a risk of explosion.

- Extinguish all open flames. Do not smoke. Do not use lighters.
- Prevent sparks. Do not operate electrical switches, including telephones, plugs or doorbells.
- Close the main gas shut-off valve.
- Open windows and doors.
- Warn all occupants, but do not use doorbells.
- Call gas company from outside the building.
- If you hear gas escaping, immediately leave the building, prevent others from entering and notify the police and fire brigade from outside the building.

1.4.2 Installation tips

 **WARNING!** **DANGER TO LIFE**
through the explosion of volatile gases.

- Work on gas components must be carried out by qualified and authorized personnel only.

 **WARNING!**

DANGER TO LIFE
from electric shock.

- Only qualified electricians are permitted to carry out electrical work.
- Before you open a device: Shut off electrical supply and secure against accidental activation.
- Please observe all installation instructions.

1.4.3 Tips for the boiler room

 **WARNING!**

DANGER TO LIFE
through poisoning.
Insufficient ventilation can result in hazardous discharge of flue gas when operation requires air from the room.

- Never block off or obstruct air ducts and vents or reduce their size.
- The boiler must not be operated until the obstruction has been removed.
- Inform the system user in writing of the fault and associated danger.

 **WARNING!**

RISK OF FIRE
through flammable materials or liquids.

- Never store flammable materials or liquids in the immediate vicinity of the boiler.

 **WARNING!**

DANGER TO LIFE
through toxic flue gases.

- Make sure that mechanical ventilation equipment, such as kitchen extraction hoods, clothes dryers or fans, does not extract combustion air from the boiler room.

 **WARNING!**

DANGER TO LIFE
through toxic flue gases.

- Make sure that the boiler is only operated with chimneys or exhaust systems that allow the required pressure during operation.

1.5 Tools, materials and equipment

Installation and maintenance of the boiler requires the standard tools used in heating, oil, gas and water installations.

The following may also prove useful:

- Sack trolley with strap or Buderus boiler trolley
- Wood supports
- Cleaning brushes and/or chemical cleaning agent for wet cleaning

If the boiler is delivered in sections, you will also require the following:

- Compression tool 1.2 if the boiler is supplied in sections (see compression tool documentation)
- Flat board
- Cleaning agent
- Installation kit (accessory)
- Steel hammer and wooden or rubber mallet
- Half-round bastard file
- Screwdriver (Philips and slotted head)
- Flat chisel
- Wrench SW 19, 36, 13, 19, 18, 24, 27 and Allen key SW19
- Support wedge, flat iron
- Cleaning rags and cloth
- Fine emery cloth
- Wire brush
- 3-in-1 oil
- Cleaning agent, ruler, chalk, straight edge
- Blanking flange with vent facility (for pressure test)

1.6 Disposal

- Dispose of packaging in an environmentally responsible manner.
- Dispose of all heating system components that have to be replaced at an authorized disposal site.

2 Product Description

This boiler is a low temperature boiler for oil or gas combustion with modulating boiler water temperature control.

The boiler consists of:

- Logamatic control panel (optional)
- Boiler jacket
- Boiler block with insulation

The control device monitors and controls all electrical boiler components.

The standard boiler is equipped with an AquaSmart™ or HydroStat control.

The boiler casing prevents heat losses and acts as a noise insulator.

The boiler block transfers the heat generated by the burner to the heating water. The insulation prevents energy losses.

Suitable burner

Install a suitable oil or a gas burner on the boiler. Note the boiler specifications when selecting the burner (→ Chapter 2.1, page 6).



CAUTION!

SYSTEM DAMAGE

due to incorrect burner.

- Use only burners that meet the technical boiler requirements.

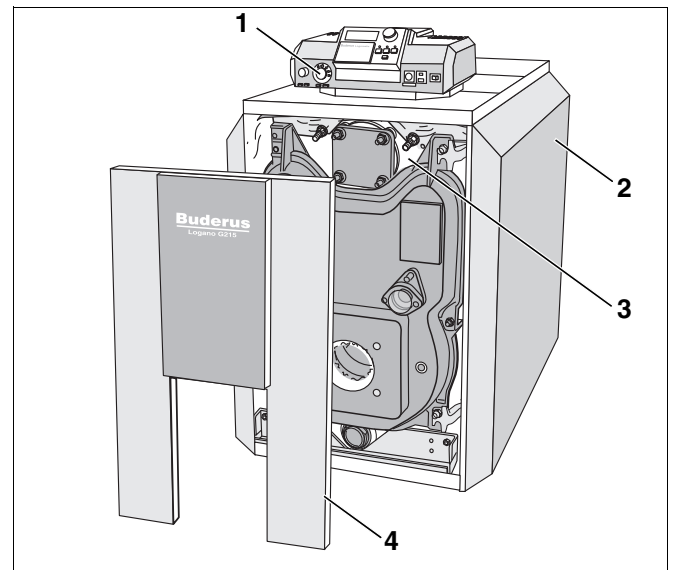

Fig. 1 Boiler without burner

- 1 Logamatic control panel
- 2 Boiler jacket
- 3 Boiler block with insulation
- 4 Burner door casing

3 Technical information

3.1 Technical data for boiler without burner

Select a suitable burner for this boiler using the information in this chapter.

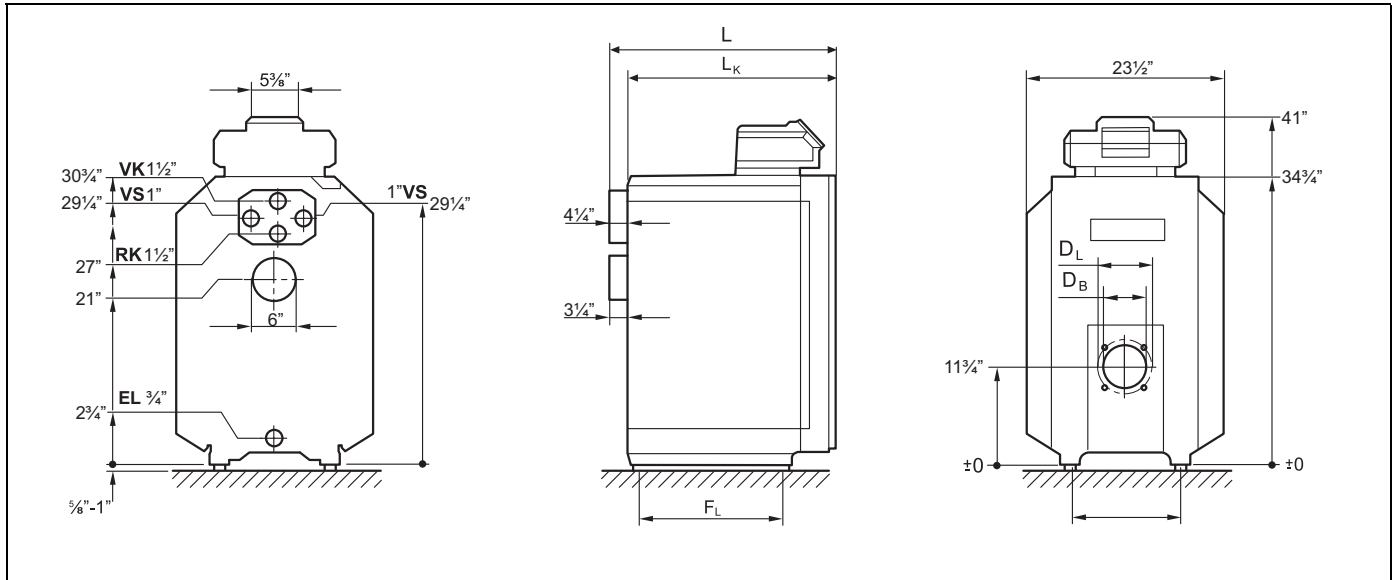

Fig. 2 Connections and dimensions (measurements in inches)

Connections (measurements see following tables):

VK = Boiler supply

VS = Hot water tank supply

RK = Boiler return

EL = Boiler drain (connection for drain valve)

Boiler model		215/3	215/4	215/5	215/6	215/7
Boiler sections	Number	3	4	5	6	7
Heating capacity (gross output)	Btu/hr	134,000	171,000	207,000	256,000	294,000
Thermal output (net IBR output)	Btu/hr	117,000	149,000	180,000	223,000	256,000
Boiler water content	Gal	approx. 12.9	approx. 16.1	approx. 19.3	approx. 22.5	approx. 25.6
Gas content	cu.ft.	1.35	1.73	2.10	2.48	2.86
Oil firing rate	GPH	1.1	1.4	1.7	2.1	2.5
Hot gas resistance	psi	0.0023 – 0.0078				
Permissible max. supply temperature ¹	°F	248				
Allowable operating pressure	psi	58				
Maximum time constant of thermostat and high limit safety cut-out (STB)	s	40				

Tab. 1 Technical data for boilers without burners

¹ Safety limit (high limit safety cut-out STB)

Maximum possible flow temperature = safety limit (STB) – 32 °F

Example: Safety limit (STB) = 212 °F, maximum possible flow temperature = 212 – 32 = 180 °F

The safety limit must comply with the national regulations.

Boiler model		215/3	215/4	215/5	215/6	215/7
Total boiler length (L)	Inch	26 ¼	31	35 ¾	40 ½	45 ¼
Boiler block length (LK)	Inch	22	26 ¾	31 ½	36 ¼	41
Boiler section insert (width; height; depth)	Inch	–			18 ⅛; 32 ¼; 5 ⅞	
Boiler block insert (width; height; depth)	Inch	18 ⅛; 32 ¼; Length LK				
Combustion chamber length	Inch	16 ¾	21 ½	26 ¼	31	35 ¾
Combustion chamber diameter	Inch	13 ¼				
Burner door thickness	Inch	3 ¾				
Burner pipe diameter (DB)	Inch	4 ⅜				5 ⅛
Hole circle diameter (DL)	Inch	5 ⅞				6 ¾
Distance between boiler feet (FL)	Inch	13 ¼	18	22 ¾	27 ¼	32
Dry weight ¹	lbs	400	500	600	700	800

Tab. 2 Dimensions, weight and other data for boilers without burners

¹ Weight incl. packaging material approx. 6 – 8 % more.

3.2 Operating conditions

If the operating conditions listed on the following page are maintained, long and trouble-free operation of the boiler can be expected. Some details relate only to operation with Logomatic control panels from Buderus.



CAUTION!

SYSTEM DAMAGE

Deviating from the stated operating conditions may lead to faults. Major deviations may lead to the destruction of individual components or of the boiler.

- Observe the details on the boiler rating label, which are decisive. Please always observe these.

3.2.1 General operating requirements

Operating conditions			
Min. boiler water temperature	Operating interruption (complete boiler shutdown)	Heating circuit control with central heating mixer ¹	Min. return temperature
In combination with Logamatic control for variable low-temperature operating modes, such as Logamatic 2107			
not obligatory Operating temperatures are safeguarded by the Logamatic control panel ²	automatically by the Logamatic control panel	not obligatory but advantageous with low-temperature heating system design 130/113 °F Required for: Underfloor heating systems Systems with high water content: >115 gal/MBH (1 MBH = 100,000 Btu/hr)	Not obligatory, except for operation with a modulating burner for: Oil combustion: 113 °F Gas combustion: 130 °F
In combination with Logamatic control for constant boiler water temperatures, such as Logamatic 2109 or in combination with remote control and aquastat			
150 °F ³	possible if, after interruption of the operation, there is at least 3 hours heating operation	required	required for: Systems with high water content > 115 gal/MBH: 130 °F Operation with a modulating burner: 130 °F

Tab. 3 General operating requirements

- ¹ A heating circuit with a mixer improves controllability and is specifically recommended for systems with several heating circuits.
- ² If the control system does not influence the heating circuits or the a heating circuit actuating component (e. g. Pumplogic), the burner ON mode must reach an operating temperature of 122 °F within 10 min by restricting volume flow.
- ³ Boiler control thermostat setting: During burner ON mode the minimum boiler water temperature in the boiler must be reached within 10 minutes by suitable measures, such as flow restriction, and maintained as the minimum temperature.

3.2.2 Boiler room and environmental conditions

Operating conditions		Notes – Requirement in greater detail
Temperature in the boiler room	+40 to +104 °F	
relative humidity	max. 90 %	No condensation or precipitation inside the boiler room
Dust/airborne seeds	–	Excessive dust inside the boiler room must be avoided when the boiler is operating, e.g.: – dust from building work Combustion air supplied from outside must not be excessively loaded with dust or airborne seed; if necessary, air filters should be fitted to prevent this: – Air supply contaminated with dust from dirt roads and paths. – Air supply contaminated with dust from production and processing facilities, e.g. quarries, mines, etc. – Airborne seed from thistles and similar
Halogen-hydrocarbon compounds	–	The combustion air must be free from halogen-hydrocarbon compounds. – Identify the source of halogen-hydrocarbon compounds and prevent them from entering. Where this is impossible, route combustion air from areas that are not contaminated by halogen-hydrocarbon compounds.
Fans, which extract air from the boiler room.	–	During burner operation, no mechanical air handling equipment may be operated that could extract combustion air from the boiler room, e.g.: – Extraction hood – Clothes dryer – Ventilation equipment

Tab. 4 Boiler room and ambient conditions

Operating conditions		Notes – Requirement in greater detail
Small animals	–	Protect the boiler room and particularly the combustion air inlet against the entry of small animals, for example by means of a screen.
Fire protection	–	Maintain clearances between the boiler and flammable materials in accordance with local regulations. A minimum clearance of 16" is required. Never store flammable materials or liquids in the vicinity of the boiler.
Flooding	–	In case of an acute risk of flooding, disconnect the boiler in good time from its fuel and power supply before water enters the room. Any general and burner components or control equipment, which come into contact with water, must be replaced before re-commissioning.

Tab. 4 Boiler room and ambient conditions

3.2.3 Combustion air supply conditions

Operating conditions	Boiler output (in case of several boilers = total output)	Ventilation air cross-section in square inches (unrestricted aperture)
Ventilation cross-section for combustion air from outside (split over a maximum of 2 apertures)	< 170,000 Btu/hr	min. 23,25 square inches
	> 170,000 Btu/hr	min. 23,25 square inches and also 0.91 square inches per 10,000 Btu/hr, that is above 170,000 Btu/hr

Tab. 5 Combustion air supply – observe local requirement for operation with room air.

3.2.4 Fuel conditions

Operating conditions		Notes – Requirement in greater detail
Permissible fuels for boilers without integral burners	–	This boiler can be operated with the following fuels. Select a burner that is suitable for one of these fuel types: <ul style="list-style-type: none"> – Fuel oil in accordance with the burner specification If a poorer quality oil (kinematic viscosity > 0.0093 sq in/sec (> 45.5 s Sayboldt) at 68 °F) is used, the maintenance and cleaning periods must be reduced. In that case, carry out maintenance and cleaning procedures at least twice a year. – Natural gas in accordance with the burner specification – LPG in accordance with the burner specification
Contamination	–	Technically free of contaminants (for example dust, mist, humidity), i.e. a constant operation will not lead to accumulation, which causes reductions in the cross-section of valves, strainers and filters.

Tab. 6 Fuels

3.2.5 Power supply conditions

Operating conditions		Notes – Requirement in greater detail
Power supply voltage	110 – 120 V	Note the voltage range of the burner and control devices used. The housing/boiler must be grounded for reasons of function and personnel protection.
Fuse (Logamatic)	10 A	
Frequency	60 Hz	Sinusoidal voltage curve
Protection	–	IP40 (protected against contact by entry of foreign bodies > 0.04 inches Ø (> 1 mm Ø), no water proofing)

Tab. 7 Power supply

3.2.6 Hydraulic conditions and water quality

Operating conditions		Notes – Requirement in greater detail
Operating pressure (overpressure)	15 – 58 psi	Maximum 30 psi with the supplied safety valve.
Permissible site test pressure	45 – 75 psi	
Protection against over-temperatures with TR thermostat	122 – 194 °F	
Temperature safety limit by STB safety temperature cut-out	210 °F	In combination with AquaSmart™ and HydroStat the limit value (210 °F) may not be exceeded.
Water quality	–	Use only drinking water to fill and top-up the boiler. We recommend a pH value of 8.2 – 9.5.

Tab. 8 Hydraulic system and water quality

4 Packaging and Components

- After delivery, check all packaging for concealed damage.
- Check the delivery for completeness.

Boiler as assembled block

Component	Qty	Packaging
Boiler block	1	1 pallet ¹
Logamatic 2107 or AquaSmart™ or HydroStat	1	1 box
Jacket Package:	1	1 box on a pallet
– Boiler jacket	1	1 box ¹
– Insulation	1	1 box ¹
– Burner door, burner door cover and assembly equipment ²	1	1 box ¹
– Technical documents		1 plastic package
B-Kit components:	1	1 package
– Supply manifold (11/4")		
– 30 psi relief valve		
– Boiler drain (3/4")		
– Pressure/temperature gauge		
– 90°-elbow (3/4")		
– Burner mounting studs and washers		
– Bushing 1" x 3/4"		
– Plug 1"		

Tab. 9 Packaging

¹ 1 pallet

² The screw-in feet are in the burner door and burner door cover package.

Boiler in parts

Component	Qty	Packaging
Front, center and back sections	1	1 pallet
Logamatic 2107 or AquaSmart™ or HydroStat	1	1 box
Jacket Package:	1	1 box on a pallet
– Fittings	1	1 box ¹
– Boiler jacket	1	1 box ¹
– Insulation	1	1 plastic package ¹
– Burner door, burner door cover and assembly equipment ²	1	1 box ¹
– Technical documents		1 plastic package
B-Kit components:	1	1 package
– Supply manifold (11/4")		
– 30 psi relief valve		
– Boiler drain (3/4")		
– Pressure/temperature gauge		
– 90°-elbow (3/4")		
– Burner mounting studs and washers		
– Bushing 1" x 3/4"		
– Plug 1"		

Tab. 10 Packaging

¹ 1 pallet

² The screw-in feet are in the burner door and burner door cover package.

5 Moving the boiler

This chapter details how to move the boiler safely.



SYSTEM DAMAGE

due to bumps.

- Please observe the handling directions on the packaging to protect components from bumps and rough treatment.



NOTICE

Protect boiler connections from damage and dirt if the boiler is not installed immediately.



NOTICE

Dispose of packaging in an environmentally responsible manner.



RISK OF INJURY

by not securing the boiler adequately during transport.

- Use only suitable means for transportation, e.g. a trolley with strap, a stair or step trolley.
- Secure the load against falling.

6 Placing the Boiler

This chapter details how to install and place the boiler in the boiler room.



SYSTEM DAMAGE

due to freezing temperatures.

- Install the boiler in a frost-free room.

6.1 Clearances

Position the boiler at the recommended clearances (→ Fig. 3). Reducing the minimum clearances makes the boiler more difficult to access.

The boiler base or foundation must be perfectly flat and level.

The burner door can be fitted with the hinge on the l.h. or the r.h. side.

Measure	Distance	
A	Recommended	51 1/8"
	minimum	39 3/8"
B	Recommended	27 1/2"
	minimum	15 3/4"
C	Recommended	15 3/4"
	minimum	3 7/8"
L _K	see "Technical Data" chapter	

Tab. 11 Recommended and minimum clearances (in inches)

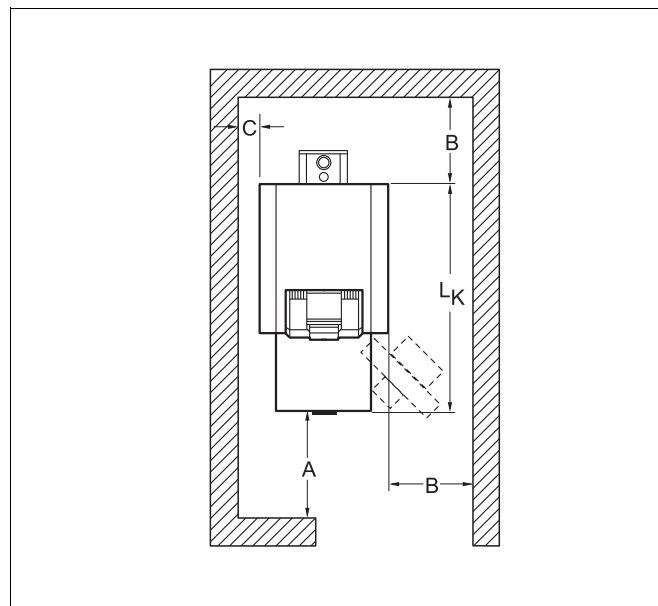

Fig. 3 Boiler room clearances (see Tab. 11)



NOTICE

Reduced clearances must comply with local and state codes. The boilers are designed for a side clearance of 6". Make sure that there is a sufficient clearance between combustible materials and the chimney connection as specified by NFPA 31 (distance of 18").



NOTICE

Where applicable, allow extra wall clearances for additional components, for example hot water tank, pipe connections, flue gas muffler or other components on the flue gas side.

7 Boiler block assembly

The on-site installation is carried out using individual sections if, because of physical limitations, a boiler block cannot be assembled as a complete unit.

For installation of boiler supplied fully assembled (→ Chapter 6.3, page 25).



RISK OF INJURY

by not securing the boiler adequately during transport.

- Use only suitable means for transportation, e.g. a trolley with strap, a stair or step trolley.
- Secure the load against falling.

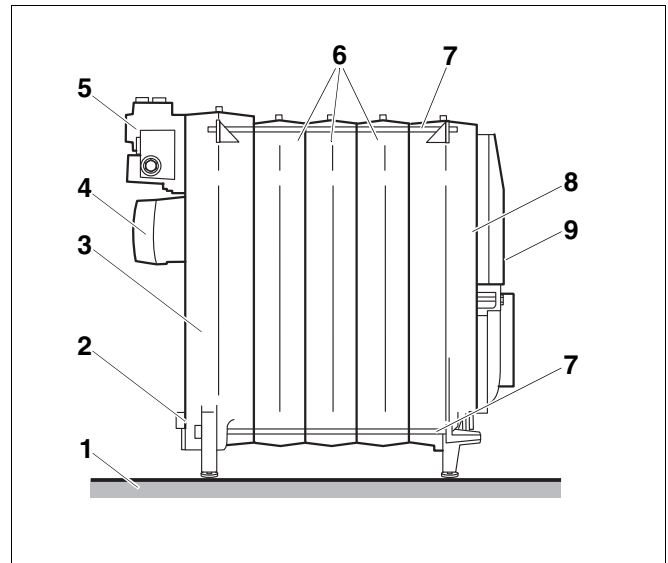

Fig. 4 Boiler block in the assembled state

- 1 Foundation/installation location
- 2 Drain
- 3 Back section
- 4 Flue outlet
- 5 Connecting block
- 6 Central sections
- 7 Anchor rods
- 8 Front section
- 9 Burner door

7.1 Assembly when delivered in sections

- Assemble all boiler sections in accordance with the following instructions and diagrams.

7.1.1 Preparing boiler sections

- Position the rear section onto two wood blocks.
- Clean the boiler hubs with sandpaper and a rag.
- Remove any burrs with a file.
- Clean the packing spring or packing groove with a wire brush and rag.



CAUTION!

RISK TO HEALTH and DANGER OF BURNS

due to released vapors and easily flammable cleaning agents.

- When using red lead putty, adhesives and solvents ensure adequate ventilation inside the installation room.
- When using solvents, avoid open flames, incandescence and sparks.
- Please observe the manufacturer's handling and safety instructions.

- Clean the hub sealing faces with a rag soaked in cleaning agent.
- Evenly coat the boiler hub sealing faces with red lead putty.
- Coat the packing spring or packing groove with adhesive (adhesive base).

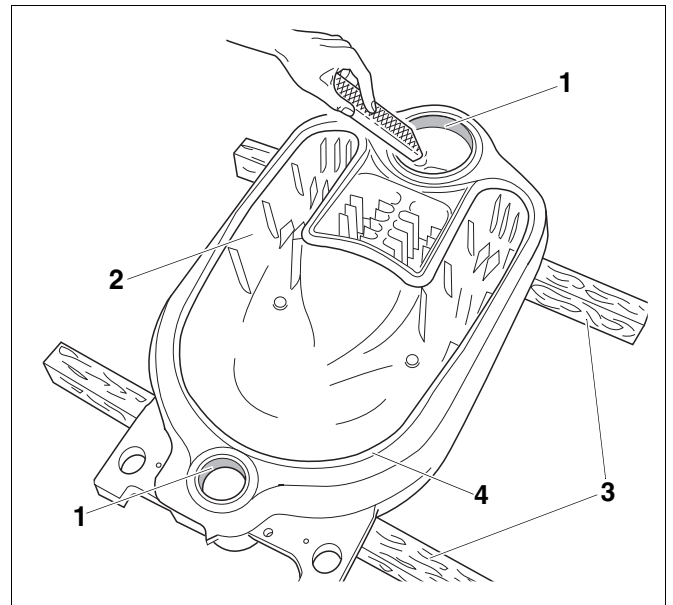

Fig. 5 Remove burrs

- 1 Boiler hubs
- 2 Back section
- 3 Wood blocks
- 4 Sealing spring

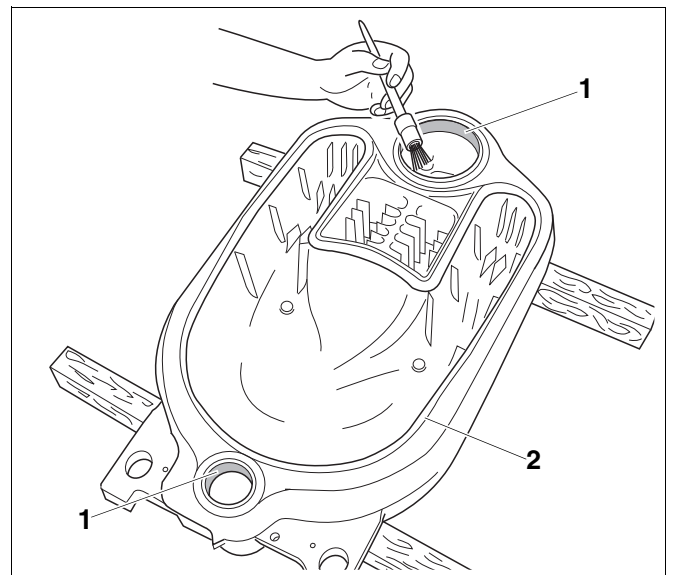

Fig. 6 Coat boiler hubs with red lead putty

- 1 Boiler hub sealing face
- 2 Sealing spring

7.1.2 Preparing push nipples and nipple ports

- Clean the nipples with a cloth soaked in cleaning agent.
- Evenly coat the nipples with red lead putty.
- Place nipple straight in the top and bottom boiler hub of the back section and hammer in a crosswise pattern.



NOTICE

After driving in the nipple leave it projecting approx. 1 1/8" from the boiler hub.

- Remove any burrs with a file.

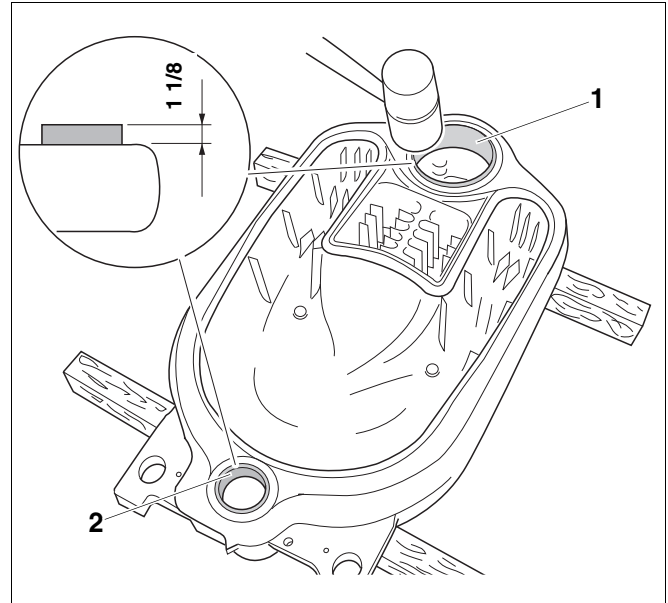

Fig. 7 Driving nipples home

- 1 Nipple in the upper boiler hub
- 2 Nipple in bottom boiler hub

6.1.3 Preparing the intermediate section

Prepare the central section in the same way as the back section (→ Chapter 6.1.1, page 15).

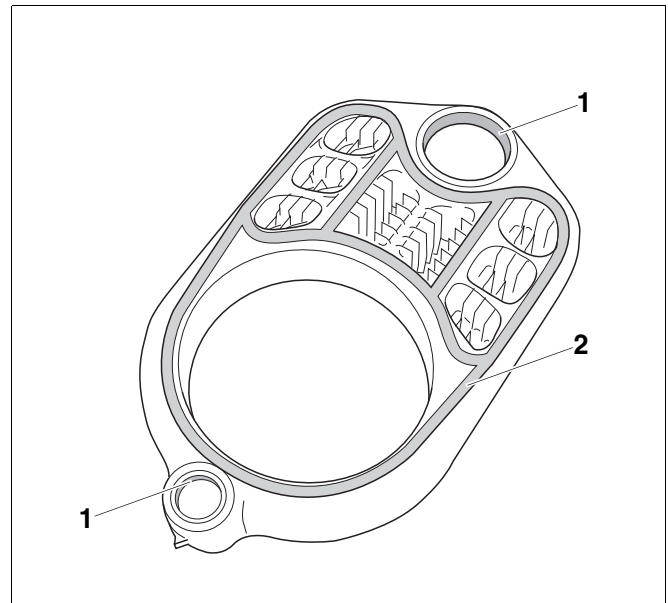

Fig. 8 Preparing the central section

- 1 Boiler hub sealing face
- 2 Packing grooves

7.1.4 Inserting the section sealing

- Unroll the required length of section sealing from the roll supplied.



CAUTION!

SYSTEM DAMAGE

due to leaking boiler sections.

- To ensure that the faces between the boiler sections are sealed correctly never stretch the sealing rope during application.
- Carefully insert the sealing rope into the boiler section packing grooves.
- Peel the backing paper from the sealing rope as you insert the cord into the packing groove.
- Insert the flexible sealing rope into the packing groove starting in the upper boiler hub area, and lightly press in.
- Overlap sealing rope 3/4" at the joins and press in well.

7.1.5 Knock intermediate section into place

- Turn the intermediate section around and locate with the upper and lower boiler hubs on the nipples of the rear section.
- Drive the intermediate section onto the rear section using a wood or a rubber mallet.

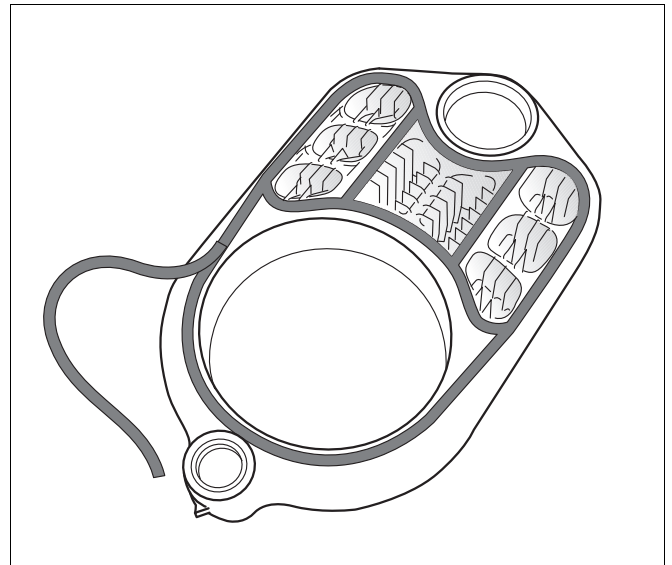

Fig. 9 Inserting the section sealing rope

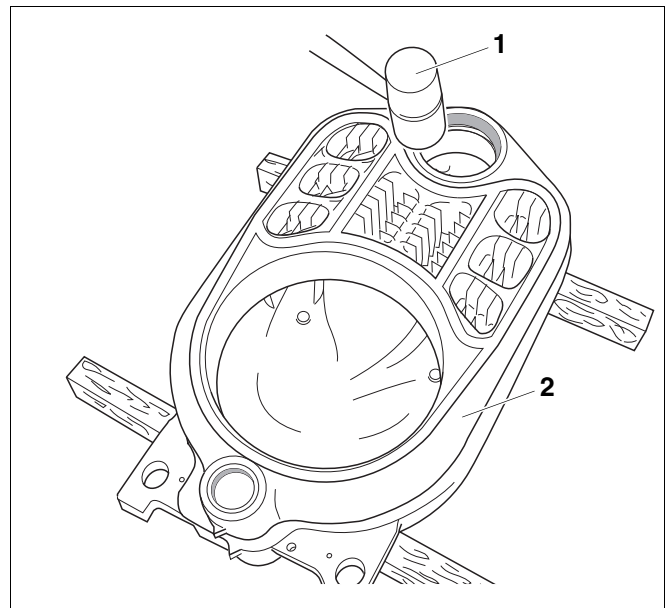

Fig. 10 Knock intermediate section into place

1 Wood or rubber mallet

2 Rear section

7.1.6 Boiler section alignment



RISK OF INJURY

due to inadequately secured boiler sections.

- Secure the boiler block section against tipping.

- Position the partly assembled block of two boiler sections.
- Position a flat board underneath the center section so that the boiler block is slightly tilted for the continuing assembly.

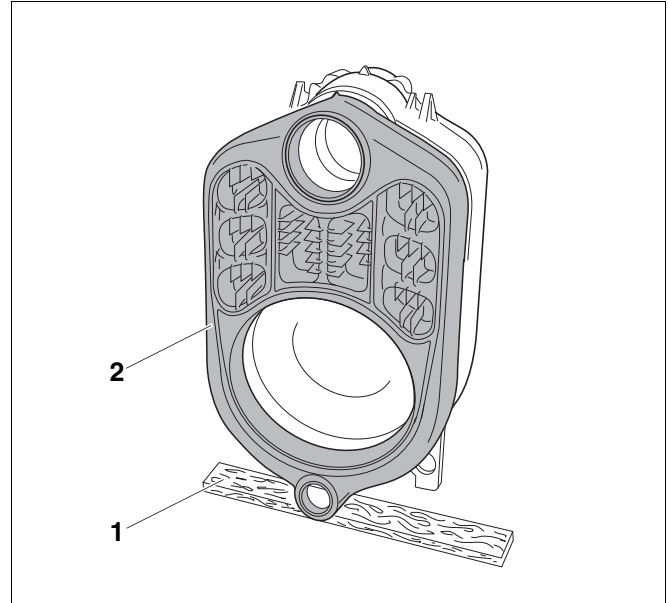

Fig. 11 Installing boiler block section

- 1 Flat board
- 2 Center section

7.1.7 Join boiler sections by the nipples at the top and bottom boiler hub



BOILER DAMAGE

due to unsuitable compression tool.

- Use only the compression tool size 1.2 (→ documents for compression tool) suitable for the boiler.



COMPRESSION TOOL DAMAGE

The compression tool may be damaged or destroyed, if you compress pull rods with loose threaded connections.

- Check the threaded connection of the pull rods after every compression, and tighten, if required. The pull rod is correctly positioned if it is fully inserted and no thread is showing.
- Keep the thread of the compression tool clean. Dirty threads can damage the compression tool during compression.

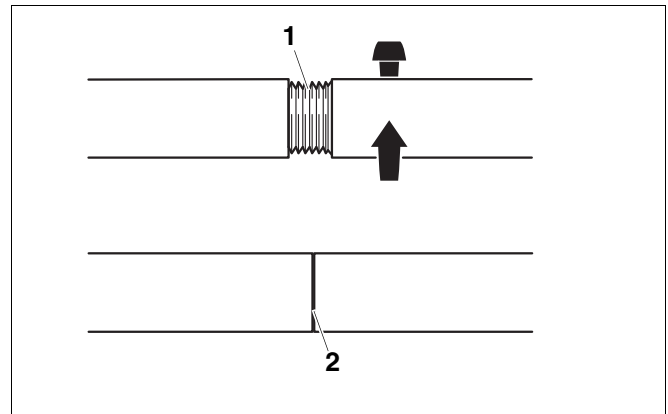

Fig. 12 Making the pull rod threaded connection

- 1 Pull rod threaded connection (incorrectly joined)
- 2 Pull rod threaded connection (correctly joined)

- Push one pull rod each through the lower and the upper boiler hub of the partly assembled block.



BOILER DAMAGE

due to incorrectly positioned auxiliary flange.

Leaks may occur if the auxiliary flange sits on the packing spring/groove of the boiler section during the compression process.

- Ensure that the auxiliary flange lies level on the boiler hubs.

- Push the auxiliary flange onto the pull rods of the lower and upper boiler hubs.
- Push the mating flange onto the pull rod of the lower and upper boiler hubs, and secure with the respective wedges.
- Thread the compression units onto the pull rod threads.



NOTICE

Push the compression units far enough onto the pull rod threads that two thread windings protrude from the compression units.

- Hold the pull rods at the center of the boiler hubs and slightly draw together the compression tools using the compression unit.

- Set both ratchet wrenches on the clamping nuts of the compression units and press the boiler sections together by evenly tightening the nuts.

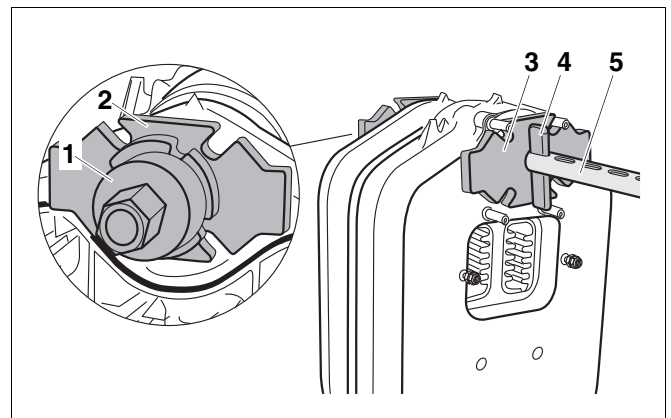

Fig. 13 Compression tool assembled at the upper boiler hub

- 1 Compression unit
- 2 Auxiliary flange (Ø 5 3/8" x 1" top boiler hub)
- 3 Mating flange (Ø 5 3/8" x 1" top boiler hub)
- 4 Wedge
- 5 Pull rod in the upper boiler hub

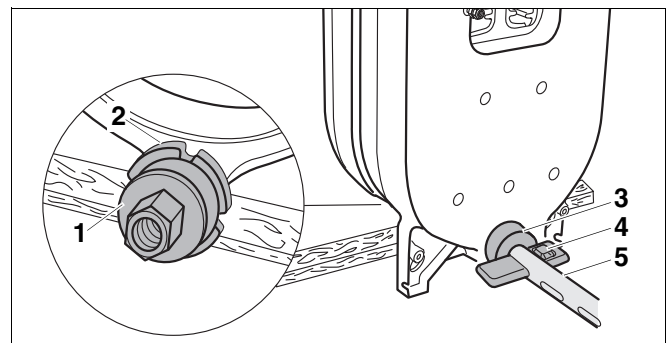

Fig. 14 Compression tool assembled at the lower boiler hub

- 1 Compression unit
- 2 Auxiliary flange (Ø 3 1/8" x 1")
- 3 Mating flange (Ø 3 1/8" x 1" bottom boiler hub)
- 4 Wedge
- 5 Pull rod in the bottom boiler hub

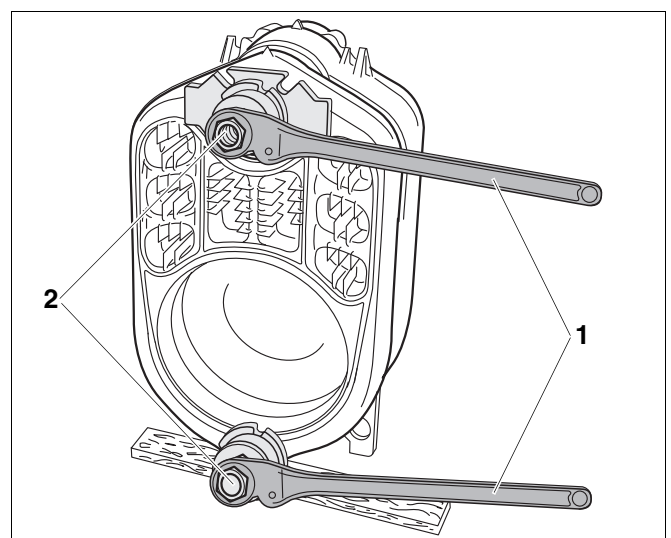

Fig. 15 Positioning ratchet

- 1 Ratchet
- 2 Clamping nut

**BOILER DAMAGE**

due to leaking boiler sections.

- For each compression procedure ensure that no more than one nipple joint (one nipple joint comprises two sections) is compressed.
- Never jam nipples into the boiler hubs of the boiler section.
- Stop pressing the sections together when the boiler hubs meet.

- Release and remove the compression tool.
- Hammer the nipples into the partly assembled boiler block (→ Chapter 6.1.2, page 16).
- Prepare all other intermediate sections as described above and join them at the nipples.

Fitting the front section

Due to the threaded studs, do not use the auxiliary flange at the front of the upper boiler hub when assembling the front section.

- Push the pull rod together with the compression unit through the upper boiler hub.
- Carry out all other steps as described (→ Chapter 6.1.7, page 18)

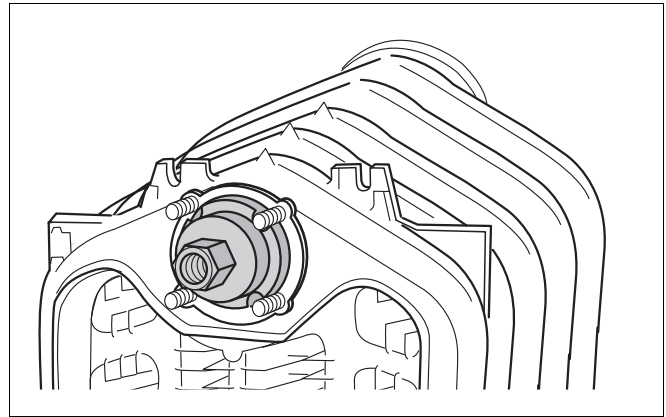

Fig. 16 Fit the compression tool to the front section

7.1.8 Fitting the anchor rods



NOTICE

Insert the anchor rods before removing the compression tool.
Never remove the compression tool first.



CAUTION!

SYSTEM DAMAGE

due to incorrect spring washer assembly.

- Ensure that the spring washers are arranged opposite each other on the anchor rods.

- Insert the anchor rods with spring washers into the case cams on the l.h. and r.h. side as well as adjacent to the lower boiler hubs.
- Tighten the nuts on the anchor rod threads by hand.
- Tighten the nuts 1 to 1½ turns on the anchor rods.
- Release and remove the compression tool.

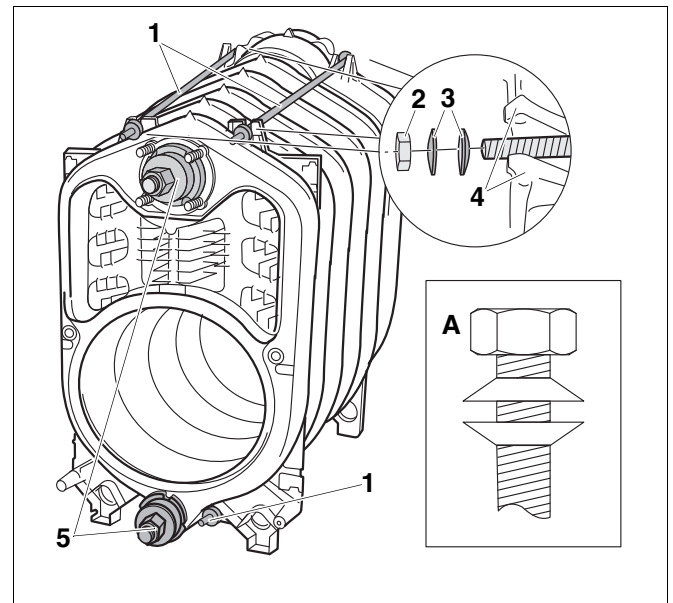

Fig. 17 Fitting the anchor rods – layout of spring washers

- 1 Anchor rods
- 2 Nut
- 3 Spring washers
- 4 Cast lugs
- 5 Compression tool
- 6 Spring washer arrangement

6.1.9 Fitting distribution tube and supply/return header

The distribution tube, the supply/return header and the sensor well are already assembled if the boiler block is supplied as a ready assembled unit.



NOTICE

Before installation of the supply/return header, first push the distribution tube from the boiler front into the boiler (don't forget the boiler hub flat gasket) if insufficient space is available behind the boiler.

- Secure the distribution tube to the supply/return header with M 8 × 16 screws and flat gasket.

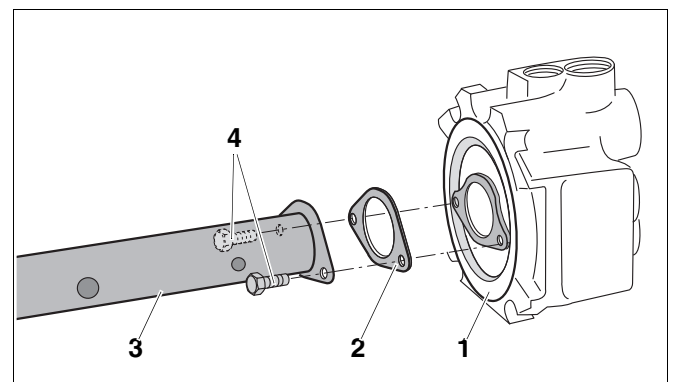

Fig. 18 Fitting feed pipe on supply/return header

- 1 supply/return header
- 2 Flat gasket
- 3 Distribution tube
- 4 M 8 × 16 bolts (brass)

7 Boiler block assembly

- Remove the nuts from the threaded studs.
- Push the flat gasket over the distribution tube.
- Push the feed pipe with the supply/return header and flat gasket into the upper boiler hub at the boiler back.

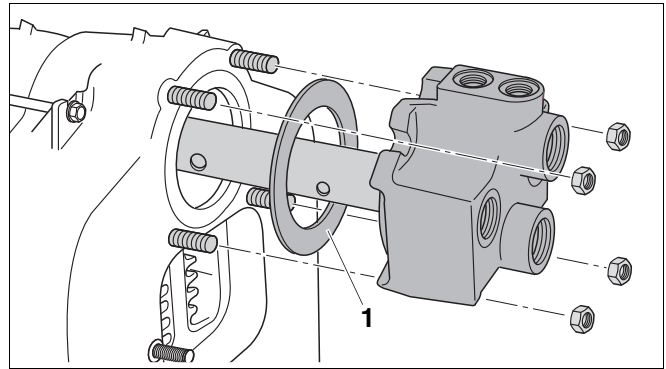

Fig. 19 Fitting feed pipe and supply/return header

1 Flat gasket

- Position the supply/return header on the threaded studs and tighten four nuts by hand.
- Evenly tighten the supply/return header nuts diagonally using a torque wrench (torque: maximum 44 lbs-ft).

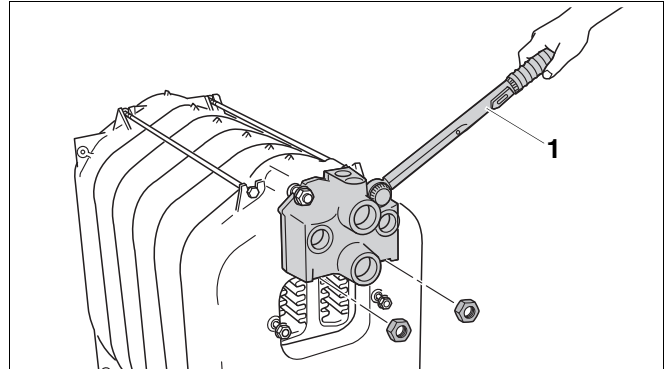

Fig. 20 Fitting supply/return header

1 Torque wrench

Seal connections which are not required with the plugs supplied. When the boiler is supplied as a ready assembled block, these plugs have already been fitted.

- Insert plugs with flat gaskets into the connections that are not required.

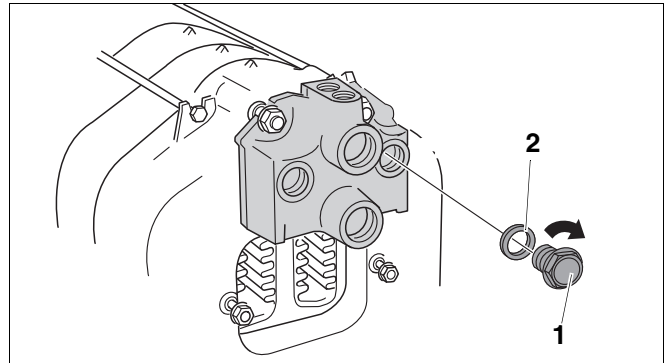

Fig. 21 Seal connections that are not required.

1 Plug

2 Flat gaskets

6.1.10 Sealing the sensor well

- Seal sensor well R $\frac{3}{4}$ from above in the Rp $\frac{3}{4}$ " well threaded hole of the test port of the connection block.

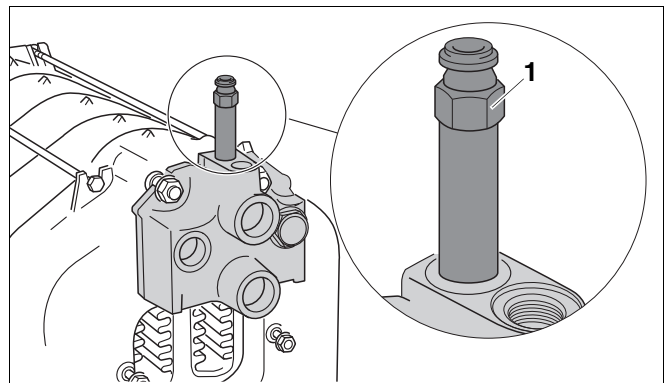

Fig. 22 Sealing the sensor well

1 Sensor well

7.1.11 Positioning the flue outlet

The flue outlet comes with sealing rope already fitted.

- Remove the washers and nuts from the threaded studs.
- Position the flue outlet on both threaded studs on the back section and secure with nuts.

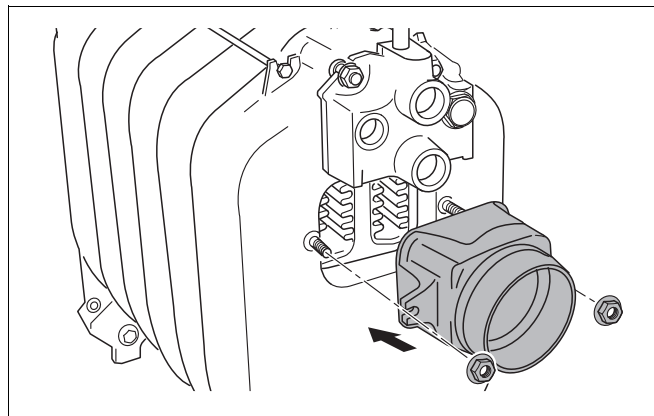

Fig. 23 Fitting the flue outlet

7.1.12 Sealing boiler hubs

The reducer included with the B-Kit is required for fitting the boiler fill and drain valve (boiler fill & drain valve). The boiler fill & drain valve is also a component of the B-Kit.

- Seal with teflon tape or paste the reducer into the bottom boiler hub at the back of the boiler.
- Install the boiler fill & drain valve on the reducer.

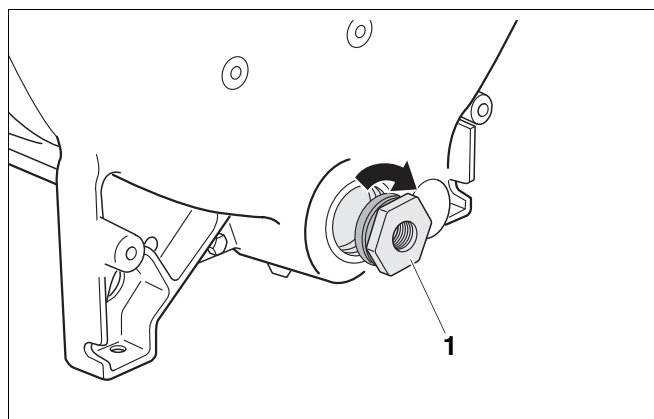

Fig. 24 Sealing the reducer

1 Reducer

- Close the top boiler hub on the front section with the blank flange.
- Screw in the plug with the flat gasket into the lower boiler hub.

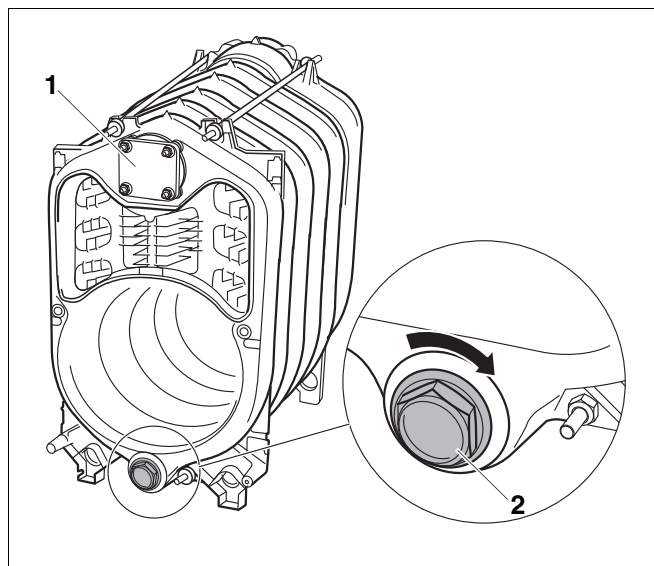

Fig. 25 Seal boiler hubs at the front section

1 Blank flange

2 Plug

7.2 Check for leaks

Conduct a leak test of the boiler block only when the boiler was delivered disassembled.

7.2.1 Preparing for a leak test

- Close all boiler hubs (→ Chapter 6.1.12, page 23).
- Close front and back connections (fit vent to the Rp ¾ connection block (→ Fig. 22)).

7.2.2 Leak test

Carry out the leak test with a test pressure of 84 psi (in accordance with the requirements of the European Pressure Vessel Directive).



NOTICE

Please note the rating plate details.

Use a pressure gauge class 1.0 for the pressure test.



CAUTION!

SYSTEM DAMAGE

due to overpressure.

- Ensure that no pressure, control or safety equipment is fitted.
- Slowly fill the boiler block via the boiler fill & drain valve. Vent at the highest point of the system, until water flows out of the air vent valve.

Hub joints leaking?

- If a hub joint is leaking, first drain the water through the fill & drain valve.
- Remove the water pipes.
- Remove the distribution tube.
- Release and remove the anchor rods.
- Separate the leaking boiler by driving flat wedges or chisels into the leaking part.



NOTICE

Clean the hubs before reassembly.

Use new nipples and new sealing rope for the reassembly.

Compress the boiler block again.

Fit the anchor rods and feed pipe.

Install the water pipework.

Repeat the leak test.

For subsequent installation of the boiler see (→ Chapter 6.3, page 25).

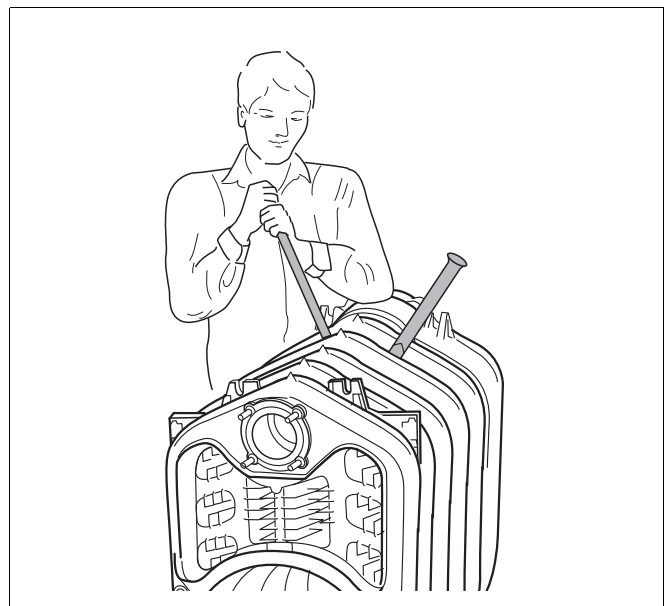

Fig. 26 Separate the boiler block

7.3 Installation when boiler is supplied assembled

A leak test of the boiler block is carried out at the factory when the boiler is supplied assembled.

- Cut through the straps.
- Remove the pallet prior to positioning the boiler block.



WARNING!

DANGER TO LIFE

from falling material.

- Ensure that a suitable means of supporting the load is available.
- Observe all locally applicable Occupational Health & Safety regulations regarding lifting equipment.

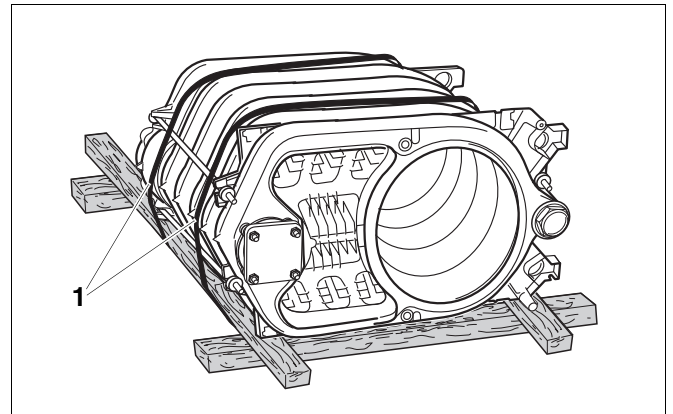

Fig. 27 Boiler block on pallet (as delivered)

1 Securing straps

7.4 Installation steps for disassembled and assembled delivery

Carry out the steps detailed in this chapter for deliveries in sections or as block. Where there are different procedures for installation between disassembled and assembled delivery, this is noted in the manual.

7.4.1 Fitting adjustable feet

Use the adjustable feet (packaging → components page 11) to adjust the boiler to a horizontal position to prevent air from collecting in the boiler.

- Tip the boiler or support it on a wood block.
- Screw in adjustable feet 0.20 - 0.40 inches.
- Gently set the boiler down.

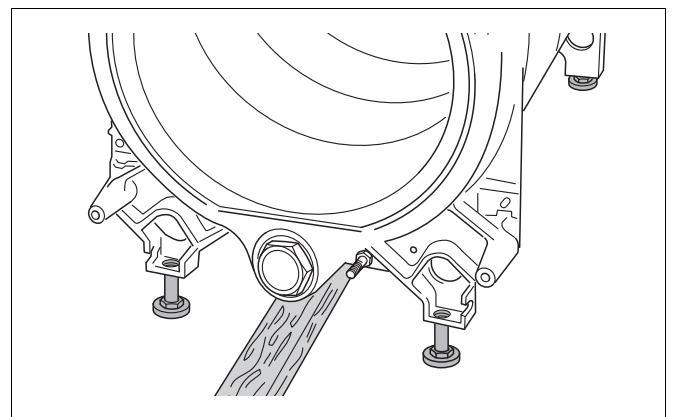

Fig. 28 Fitting adjustable feet

7.4.2 Insert the flue gas baffle plates

- Remove the corrugated cardboard packaging when the block is supplied ready assembled.
- When the boiler is supplied in sections, remove the flue gas baffle plates from the carton containing the small iron fittings.
- Install flue gas baffle plates in accordance with the following table into the central second flue gas pass. The cast lugs should point towards the center of the boiler.

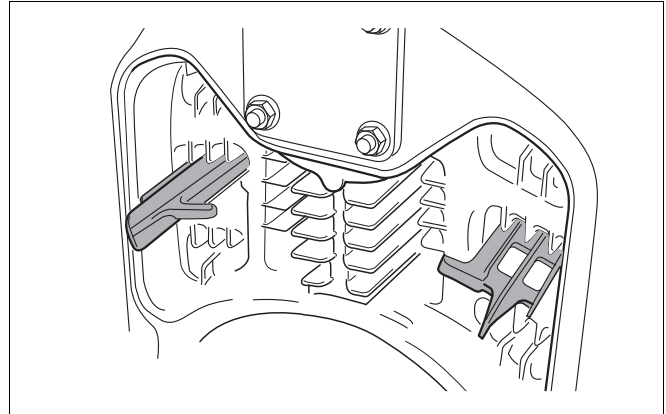

Fig. 29 flue gas baffle plates into the second flue gas pass (here: centrally)

- Install flue gas baffle plates in accordance with the following table into the third flue gas pass. The cast lugs should point outwards.

Boiler section		3	4	5	6	7
2. flue gas pass	top	2	–	–	–	–
	center	2	–	–	–	–
	bottom	2	–	–	–	–
3. flue gas pass		2	2	2	2	–

Tab. 12 Arrangement of the flue gas baffle plates

The flue gas temperature can be increased by removing the flue gas baffle plates (→ Chapter 8.6.1, page 44).

7.4.3 Installing the burner door

The burner door can be mounted either on the r.h. side and on the l.h. side. Installation on the r.h. side is described below.

- Screw the two hinge pins to the front section with one M12 × 35 hexagon bolt each.

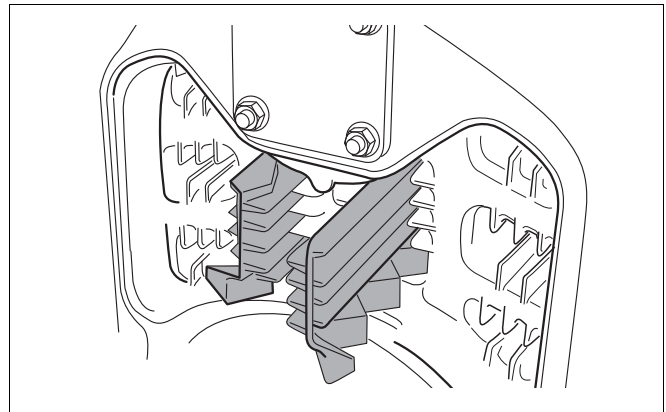

Fig. 30 flue gas baffle plates into the third flue gas pass

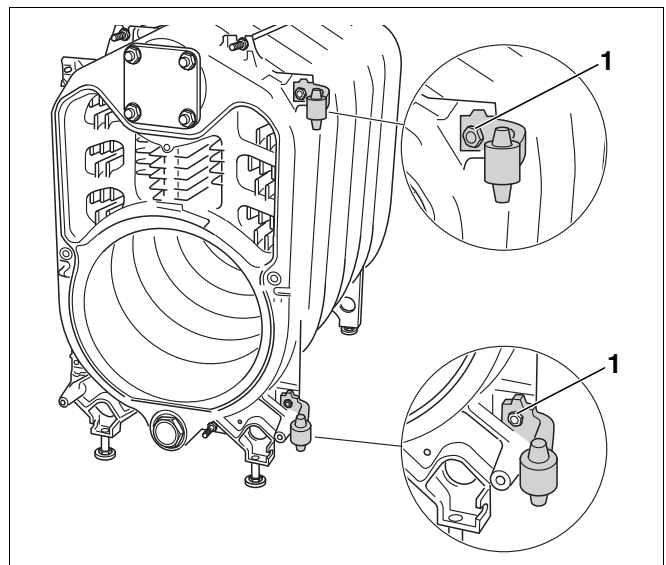

Fig. 31 Fit hinge pins (here: on the r.h. side)

1 M12 × 35 hexagon bolt

- Secure both slotted hinge lobes with one M12 × 25 hexagon bolt each to the burner door.
- Hook the burner door with the hinge lobes onto the hinge pins.
- Close the boiler door.

**CAUTION!****SYSTEM DAMAGE**

due to leaking burner door.

- Tighten the hexagon bolts of the burner door evenly.

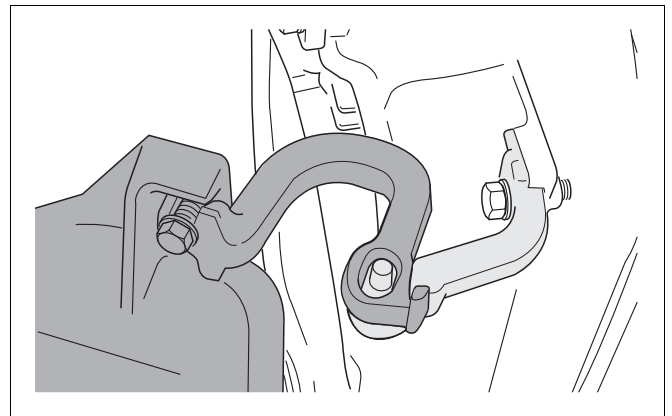

Fig. 32 Hooking on the burner door (here: on the r.h. side)

1 M12 × 25 hexagon bolt

7.4.4 Fitting the boiler jacket

Installation of the boiler back panel

- Screw spacer pins to the rear section.

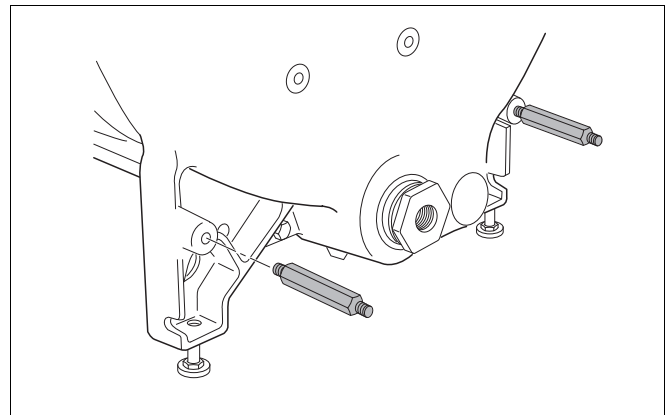

Fig. 33 Spacer pin installation

7 Boiler block assembly

- Secure the boiler back panel with nuts to the threaded and spacer pins.

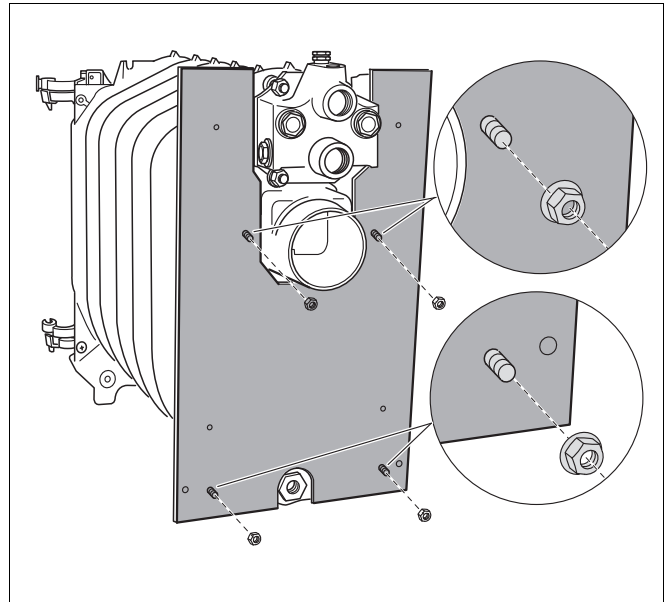

Fig. 34 Installation of the boiler back panel

- **Installation of the top tie-bar**
- Secure the top tie-bar with the nuts supplied to the anchor rod threads.

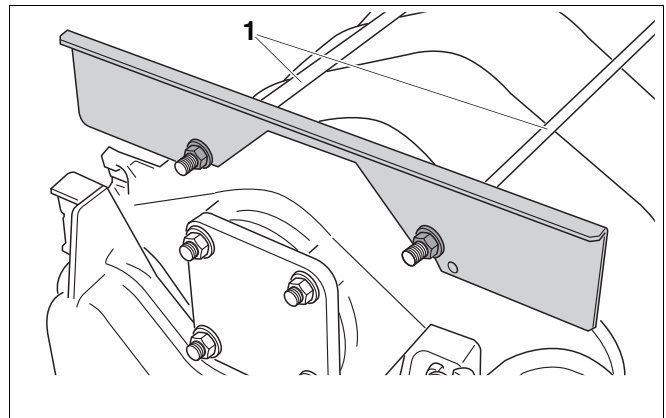

Fig. 35 Fitting the top tie-bar

1 Anchor rods

Fitting the bottom tie-bar

- Screw the bottom cross bar with hexagon bolts to the front section.

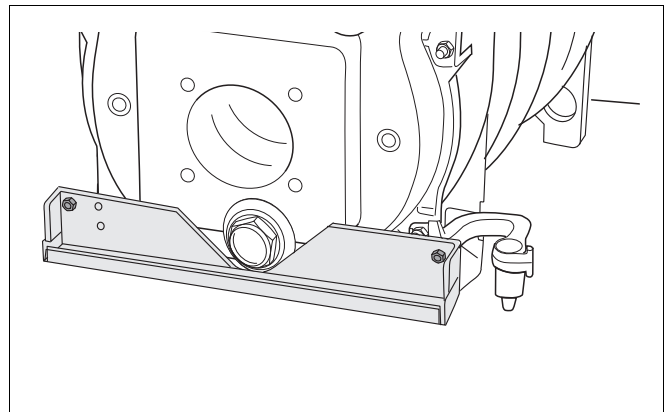

Fig. 36 Fitting the bottom cross bar

Installing thermal insulation

- Position the thermal insulation over the boiler block.
- Push the thermal insulation below the boiler block in the direction of the arrow.
- Position the thermal insulation tabs in front of the top tie-bar and draw them together with a spring clip.

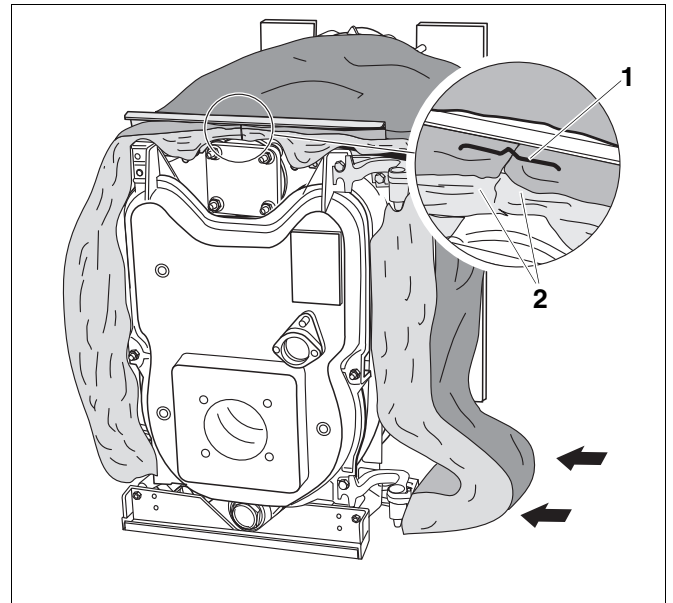

Fig. 37 Installing thermal insulation

1 Spring clip

2 Thermal insulation tabs

Fitting the side panels

The side panels are fitted identically on each side (r.h. side panel shown here)

- Push the snap nut onto the angled sheet steel of the side panel until it locks into the hole provided.

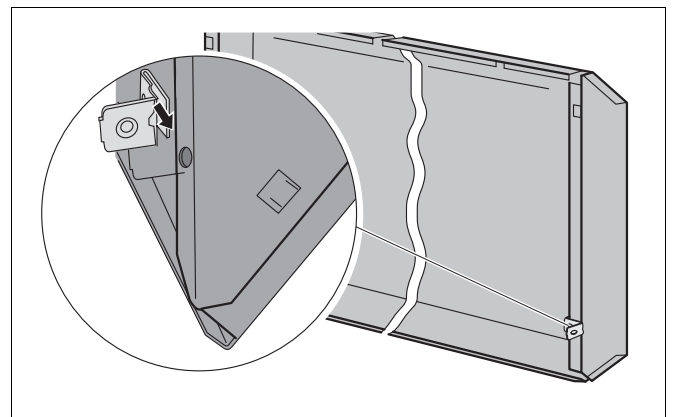

Fig. 38 Positioning snap nut (here: r.h. side panel)

- Push the side panel into the angled part of the bottom cross bar.

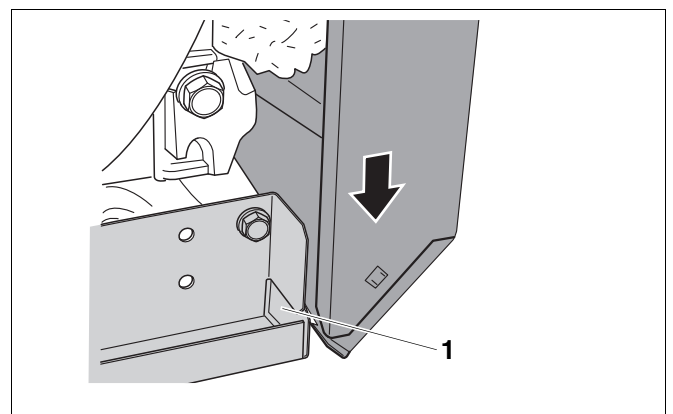

Fig. 39 Push in the bottom front corner of the side panel

1 Angled part of the bottom cross bar

7 Boiler block assembly

- Slightly lift the side panel.
- Hook the side panel upper cutout into the upper tie-bar.
- Hook the rear part of the side panel to the extended hook.

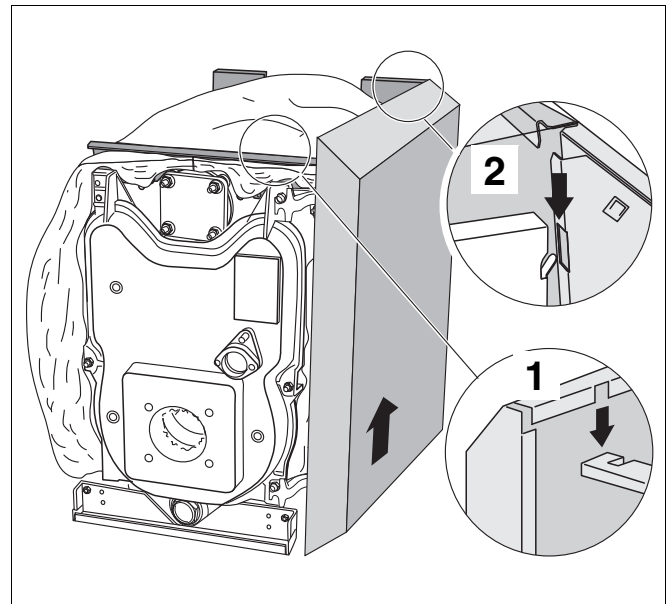

Fig. 40 Slot side panel into place

- 1 Top tie-bar
- 2 Extended hook

- Push against the lower end of the side panel and secure with the rear panel using the snap nut.

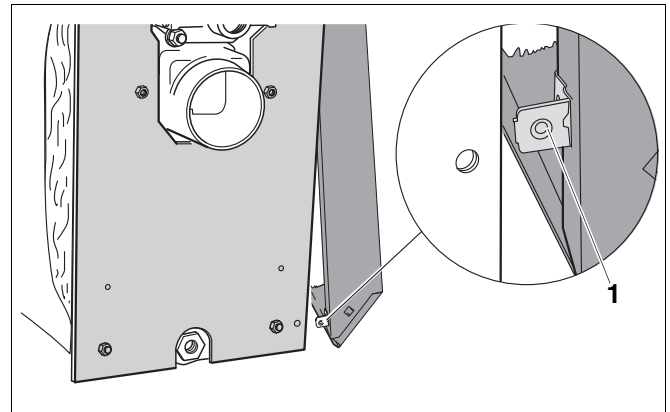

Fig. 41 Fasten the side panel to the rear panel with screws

- 1 Snap nut

Installing the top front boiler cover

- Hook the front boiler cover with its cutout into the upper tie-bar and push back.
- Secure the front boiler cover with two self-tapping screws to the side panels.



NOTICE

Installation of the back boiler cover
(→ Chapter 7.9, page 41).

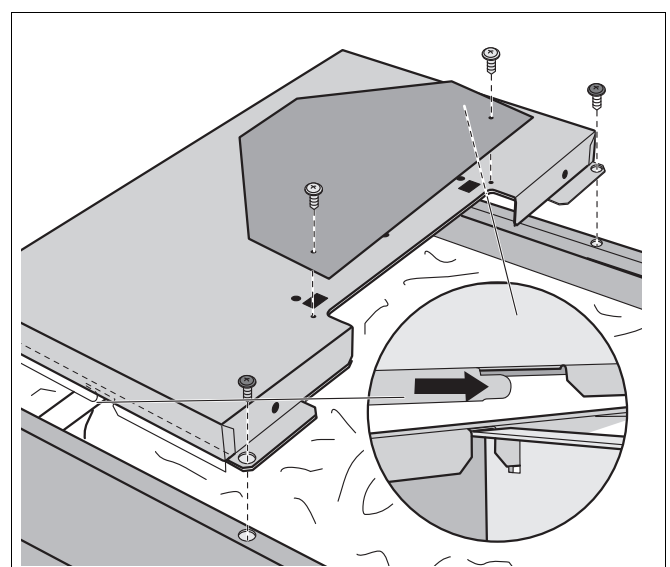

Fig. 42 Installing the front boiler cover

Fitting the cable entry

- Screw the cable entry to the hole in the boiler back panel.

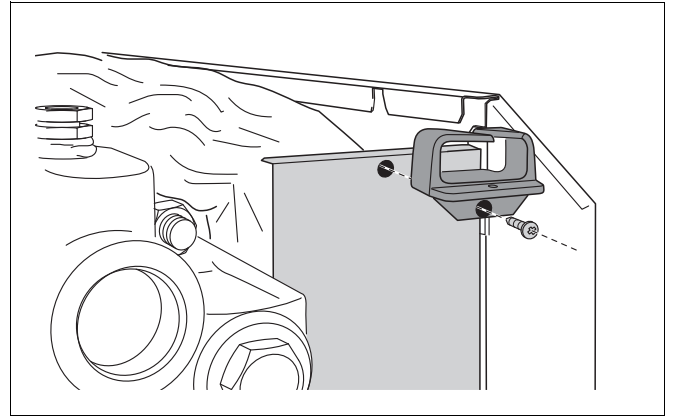

Fig. 43 Fitting the cable entry

7.5 Positioning and leveling the boiler

- Position the boiler in its final location.
- Level the boiler horizontally by turning the adjustable feet and using a spirit level.

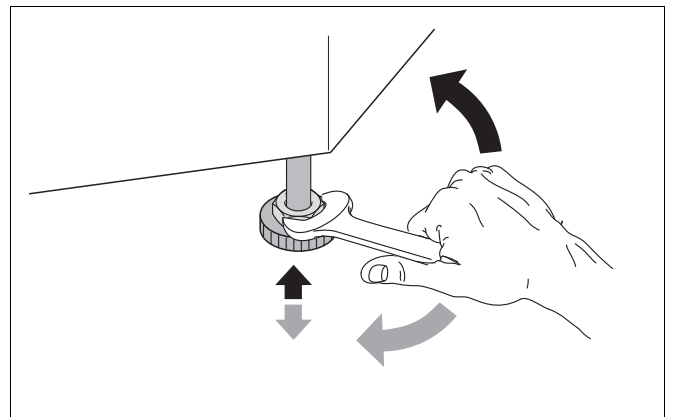

Fig. 44 Leveling the boiler horizontally

8 Boiler installation

This chapter details how to install your boiler correctly. These details include:

- Flue connection
- Water connections
- Electrical connection
- Burner installation (field installation)
- Fuel connection

8.1 Flue connection

8.1.1 Chimney venting

Connect boiler to vertical chimney with a 6" vent pipe. Use only venting systems that comply with local codes and regulations. If local codes are not available, refer the the following regulations:

- NFPA 31, Installation of Oil-Burning Equipment,
- NFPA 211, Standard for Chimneys, Fire Places and Solid Fuel Burning Appliances,
- In Canada refer to CSA B139, Installation Code for Oil-Burning Equipment,
- NFPA 211 requires chimney to be lined before connecting boiler.

Inspecting and cleaning existing flue

Inspect and clean the old flue before installation of the new boiler.

- Remove blockages and dirt from the chimney.
- Clean chimney
- Repair or replace faulty flues.
- If necessary, repair chimney with mortar and joints.

Down drafts



NOTICE

To prevent down drafts extend chimney at least 3 feet above the roof opening at least 2 feet above any part of the roof within a radius of 10 feet.

Minimum clearances to combustible objects

Flue pipe	Type	Minimum clearance
Double-wall	L	6"
Single-wall	L	18"

Tab. 13 Minimum clearances to combustible objects for flue systems

Minimum size of chimney

The minimum recommended chimney size is 8" x 8" (6 3/4" x 6 3/4" inside liner) or 6" diameter with a minimum height of 20 feet. Use a 6" flue pipe for connection to an existing chimney.

Installing the flue pipe

- Slide 6" Insert flue pipe onto the flue outlet and secure with 2 screws.



NOTICE

Avoid long horizontal flue pipe runs and keep the number of bends to a minimum.

- Install flue connections between boiler and chimney to slope up at least 1/4" per foot to the chimney.
- Connect the flue pipe to the chimney above the bottom of the chimney to prevent blockages.
- Install cleaning and service hatches for cleaning the flue system.

After starting the burner, set breeching draft to -.01 to -.02 inches WC with a draft gauge. (The overfire pressure can be positive). If necessary, install draft controllers in the flue system to maintain the negative pressure in the system or to meet code requirements. Always install the draft controller in vertical position. Use a draft gauge when making adjustments.

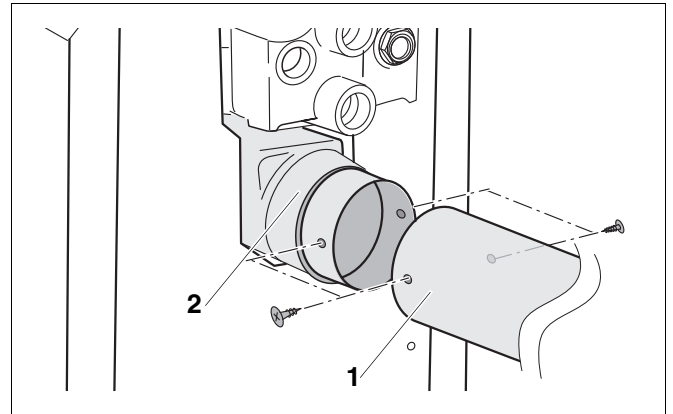

Fig. 45 Installing the flue pipe

- 1 Flue pipe
- 2 Boiler flue outlet

8.2 Installation of water connections

8.2.1 Installing B-Kit:

The relief valve and the pressure/temperature gauge are mounted on the conversion nipple (included in B-Kit) on the VK boiler supply connection as follows:

- Measure length of thread on R1¼" × 1¼" NPT double nipple.
- Seal supply manifold to connection VK with the long side to the boiler.

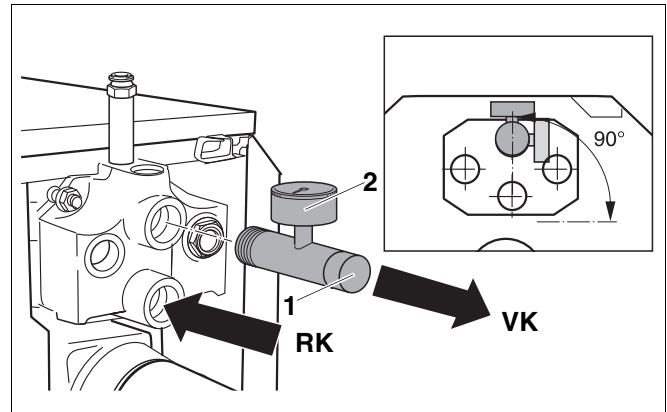

Fig. 46 Installing B-Kit

- 1 Supply manifold
- 2 Pressure/temperature gauge

- Seal conversion nipple on boiler inlet VK.
- Seal pressure/temperature gauge to conversion nipple.



NOTICE

Do not install the pressure relief valve until after the leak test (→ Chapter 7.3, page 35).

The pressure relief valve must be installed in a vertical position.

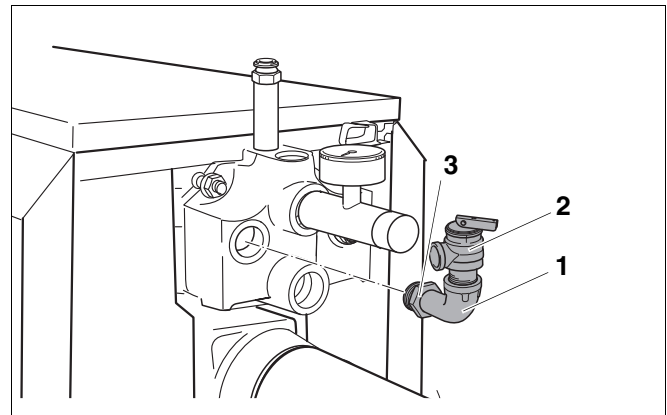

Fig. 47 Installing B-Kit

- 1 90°-elbow 1¼" NPT
- 2 Pressure relief valve
- 3 Conversion nipple 1" x ¾"

8.2.2 Installation of boiler drain (included in B-Kit)

- Install the boiler fill and drain valve with seal to connector EL.
- Seal boiler drain to connection EL.

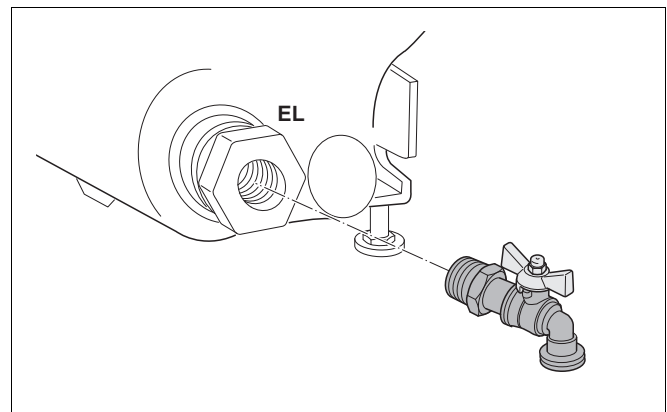

Fig. 48 Installation of boiler drain

8.2.3 Installation of system components

See the installation diagram for recommended installation of the heating system components.

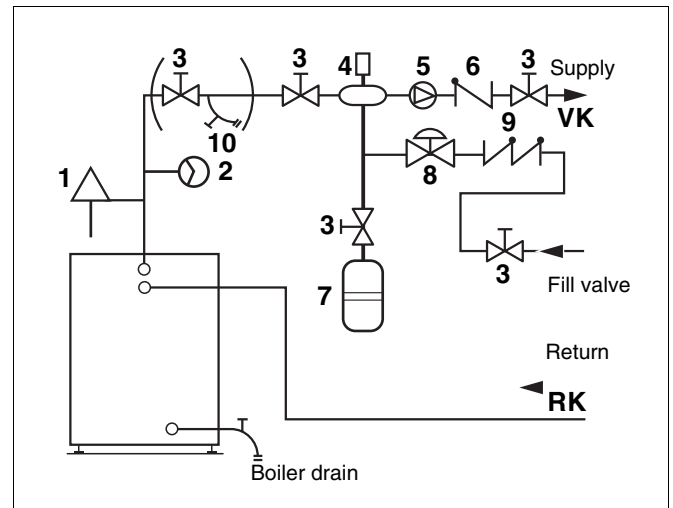

Fig. 49 Installation diagram

- 1 Pressure relief valve
- 2 Pressure/temperature gauge
- 3 Ball or stop valve
- 4 Air eliminator
- 5 System pump
- 6 Back flow preventer
- 7 Expansion tank
- 8 Automatic feed valve
- 9 Check valve
- 10 Purge station

8.3 Filling heating system and checking for water leaks

When the boiler is delivered assembled it is checked for leaks at the factory. Before placing the heating system into operation, check it for leaks to prevent leaks occurring during operation. When supplied disassembled (→ Chapter 6.2, page 24).



SYSTEM DAMAGE

due to overpressure during leak testing. Pressure, control and safety equipment may be damaged by excessive pressure.

- When you carry out a leak test, make sure that no pressure, control or safety equipment is fitted which cannot be isolated from the boiler water chamber.

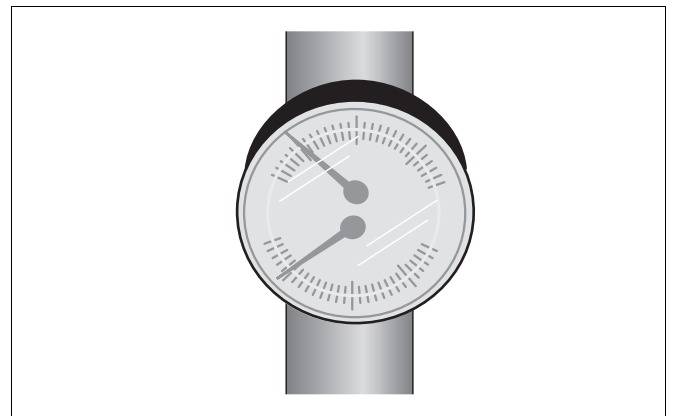

Fig. 50 Pressure/temperature gauge

Carry out the leak test at 1.5 times the standard operating pressure and in accordance with the codes.

Maximum operating pressure	Maximum site test pressure
30 psi (with the supplied pressure relief valve)	45 psi
58 psi (with a different pressure relief valve)	75 psi

- Seal pressure relief valve connection (→ Fig. 47 page 34) and all other open connection with blind plugs.
- Close the expansion tank from the system by closing the cap valve.
- Open the mixing and shut-off valves on the heating water (primary) side.
- Connect the hose to the water tap. Attach a hose filled with water onto the hose connection of the boiler fill & drain valve, fasten with a hose clip and open the valve.
- Slowly fill the boiler with water from the tap.
- Open the cap of the automatic air vent by one full turn to allow air to escape.
- Slowly fill the heating system. Observe the pressure gauge while filling.
- Close the water tap and the boiler fill & drain valve once the required operating pressure has been reached.
- Check the connections and pipework for soundness.
- Bleed the system via the radiator bleed valves.
- Top off with water if the pressure drops as a result of bleeding the system.
- Installing pressure relief valve (→ Fig. 47 page 34).
- Remove the hose from the boiler fill and drain valve.

7.4 Burner installation

Only one burner that complies with the technical data of the boiler can be mounted on boilers without integrated burners (→ Chapter 2, page 6).



SYSTEM DAMAGE

due to incorrect burner.

- Only use burners which meet the technical boiler requirements.

- Screw studs included with the B-Kit to the burner door.
- Fit the burner to the hole circle of the burner door.

**NOTICE**

Approved burners with accessories (such as aquastat and circulator) are also available as a package from Buderus Hydronic Systems.

- Install burner with the correct nozzle and settings (air, pump pressure, turbulator settings, flange position).
- Place the seal on the studs and secure the burner with the included nuts.
- Follow the manufacturer's direction for installation, fine adjustment and regular maintenance procedures.

**NOTICE**

For the correct burner settings see the → documentation for the flue system and the → burner.

- Wire up the burner (see → documentation for burner).

8.5 Providing a fuel supply

Make the fuel connection in accordance with all locally applicable regulations. We recommend the installation of a fuel filter.

- Visually inspect the fuel pipe and clean or replace, if necessary.
- Install a shut-off valve into the fuel supply pipe.
- Connect the fuel pipe free of stress to the boiler.
- Check the fuel line for leaks.

8.6 AquaSmart™ installation

The AquaSmart™ controls the boiler supply temperature.

- For Installation and Operation of the AquaSmart™ Control and sensor well see the AquaSmart™ Installation Instructions supplied with the control. For wiring diagrams of the AquaSmart™ → Chapter 11, page 55.
- Install AquaSmart™ and sensor well as specified by the installation manual.

For operating the boiler with AquaSmart™ control see instructions supplied with the controller.

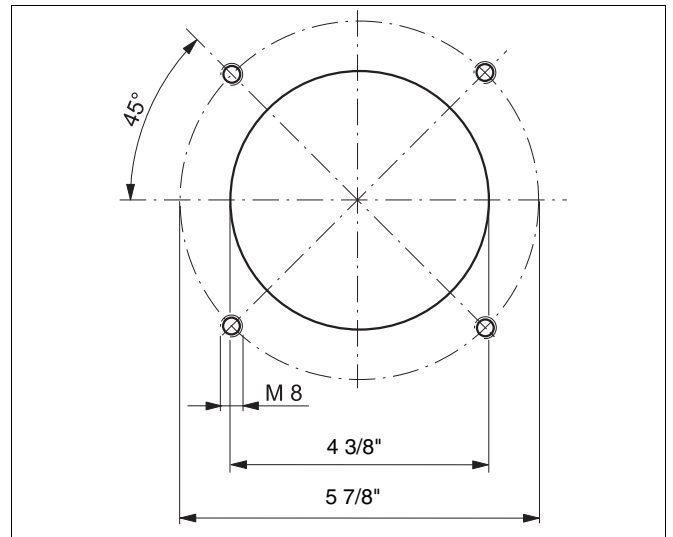

Fig. 51 Burner door mounting holes

8.7 HydroStat installation

The HydroStat controls the boiler supply temperature.

- For Installation and Operation of the HydroStat Control and sensor well see the HydroStat Installation Instructions supplied with the control. For wiring diagrams of the HydroStat → Chapter 11, page 55.

8.8 Electrical connections

This section only applies to boilers using Buderus Logamatic 2107 controls.



WARNING!

DANGER TO LIFE

from electric shock.

- Only qualified electricians are permitted to carry out electrical work.
- Before you open the control: shut off electrical supply and secure against accidental activation.
- Please observe all installation instructions.

8.8.1 Fitting the Logamatic control panel

- Locate the push-in hooks of the Logamatic control panel in the slots.
- Push the control panel towards the burner door.
- Let the flexible hooks of the control panel click into the openings by pushing the control panel down.

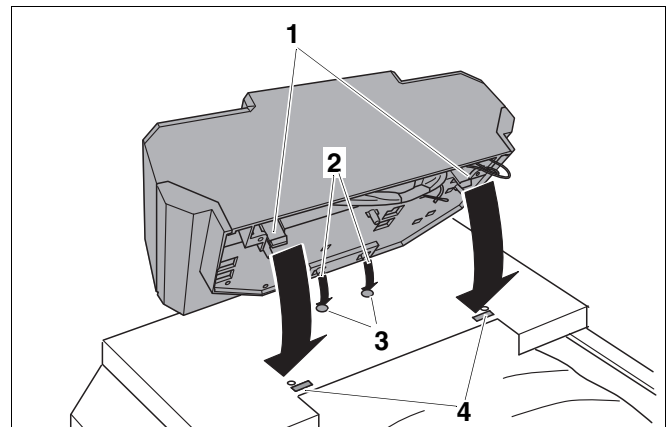

Fig. 52 Fitting the control panel

- 1 Flexible hooks
- 2 Locking tabs
- 3 Slots
- 4 Openings

- Remove the Logamatic control panel cover. First remove the cover screws.
- Secure the control panel with self-tapping screws.

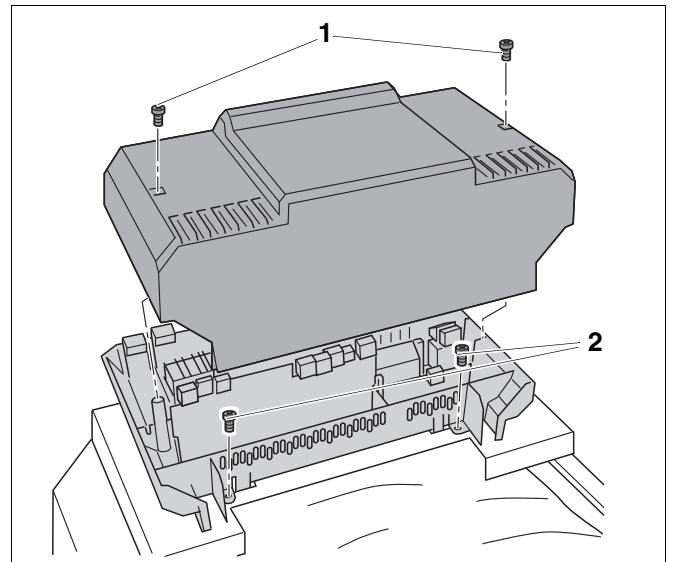

Fig. 53 Removing the cover

- 1 Cover screws
- 2 Self-tapping screws

8.8.2 Installation of the temperature sensor set and burner cable



CAUTION!

SYSTEM DAMAGE

Capillary tubes may become unsound due to severe kinking or sharp burrs.

- Carefully route capillary tubes using large radius.
- Route capillary tubes and sensor wiring through the cable opening of the front boiler jacket and connect to test port.
- Roll up surplus capillary tubes and sensor lead and lay them on the thermal insulation.
- Route the burner cable through the cable entry in the front boiler cover to the control panel.
- Connect the burner cable to the control in accordance with the terminal markings.

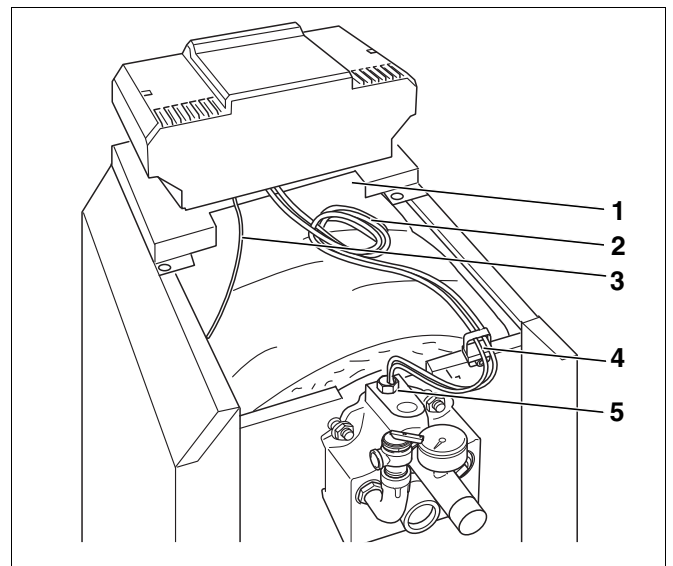

Fig. 54 Routing and connecting cables

- 1 Cable entry in the front boiler cover
- 2 Capillary tubes and sensor cable
- 3 Burner cable
- 4 Cable entry
- 5 Sensor well (test port)

**NOTICE**

If an AquaSmart™ or Hydrolevel HydroStat is being installed the factory-fitted immersion well must be replaced by the immersion well supplied with the control.

- Slide temperature sensor bundle set with compensating spring into the sensor well to the stop. The plastic spiral is then pushed back automatically.
- Push the sensor holder (included with the control device) over the side of the sensor well head.

**NOTICE**

Ensure good contact between the sensor surfaces and the sensor well to ensure good temperature transfer. Use the compensating spring.

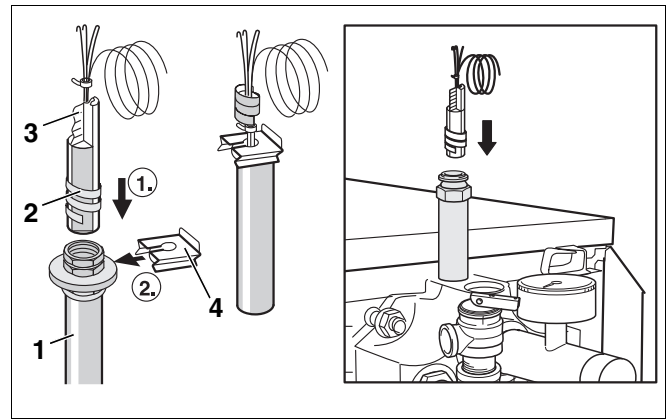

Fig. 55 installing the temperature sensor set

- 1 Sensor well
- 2 Plastic spiral
- 3 Compensating spring
- 4 Sensor holder

8.8.3 Electrical connections and connection of additional components

Install a permanent electrical power connection in accordance with local codes.



RISK OF FIRE

Hot components may damage electrical wiring.

- Ensure that all wiring is routed in the ducts provided or on the boiler insulation.

- Route all cables through the cable entries to the Logamatic control panel and connect in accordance with the wiring diagram.

8.8.4 Strain relief installation

Secure all cable runs with cable ties (included with the control):

- Insert the cable ties together with the cable from the top into the slots of the clamp frame (step 1).
- Push the cable tie down (step 2).
- Push against the tie (step 3).
- Flick the toggle up (step 4).

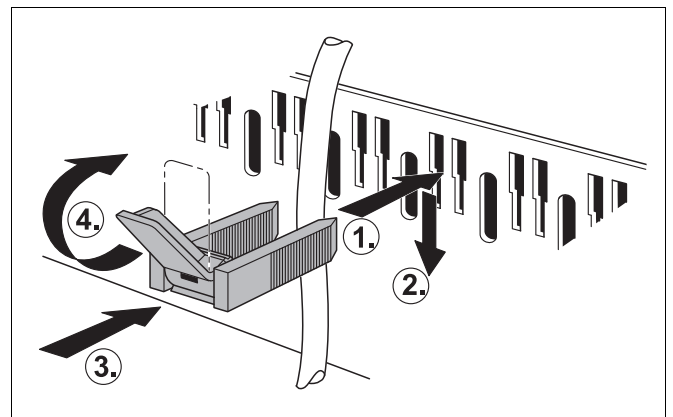

Fig. 56 Securing cables with cable ties

8.9 Jacket panel installation

- Locate and secure the Logamatic control panel top device cover.
- Fit the rear boiler cover.

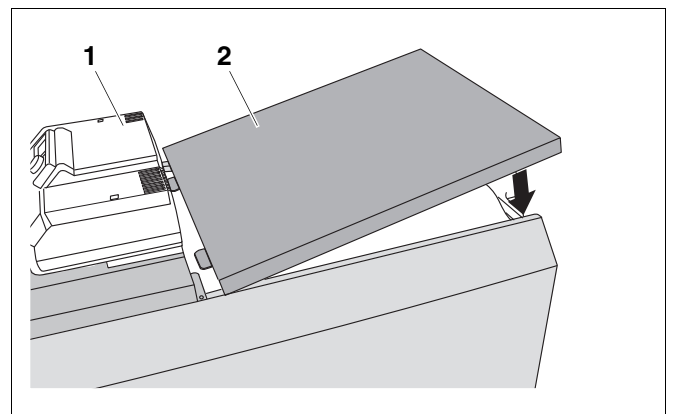

Fig. 57 Install the back boiler cover

1 Control panel cover

2 Back boiler cover

9 Placing the boiler in operation

This chapter describes the initial start-up procedure regardless of the installed control device.

- Complete the start-up protocol during this process (→ Chapter 8.9, page 46).

Further information on boiler room layout and clearances, combustion air requirements and venting systems and boiler operational requirements can be found in → Chapter 2.2, page 7.



BOILER DAMAGE

due to excessive dust and air contamination.

- Do not operate the boiler under very dusty conditions, e. g. caused by building work inside the installation room.
- Install an air filter if the air supply is very dusty (for example from unmade roads and tracks in dusty working environments, such as quarries, mines etc.) or airborne seed from blossoms.

9.1 Setting the operating pressure

Set the operating pressure required before initial start-up.



SYSTEM DAMAGE

due to material stress as a result of temperature differentials.

- Fill the system with cold water (the flow temperature should be no more than 100 °F).
- Adjust the red pointer of the pressure gauge to the required operating pressure, i.e. at least 15 psi (applicable to sealed systems).
- Top up the heating water or drain via the boiler fill and drain valve until the required operating pressure has been reached.
- Vent the heating system during filling.

9.2 Check pressure relief valve

- Make sure that no persons are in the discharge area of the pressure relief valve.
- Raise the lever on the pressure relief valve.

The pressure relief valve must open and release pressure. If the pressure relief valve does not discharge, it must be replaced, because system components may be damaged by excessive pressure.

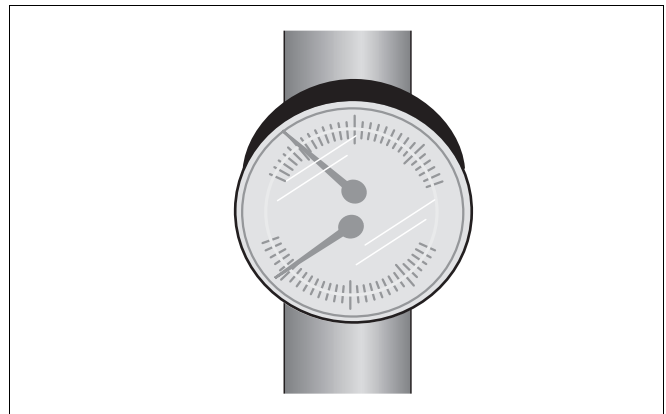

Fig. 58 Pressure/temperature gauge for showing operating pressure and feed temperature

9.3 Making the heating system operational

- Open fuel feed on the main shut-off valve.
- Switch on the heating system emergency stop switch (if installed) and/or switch the corresponding house circuit-breaker.

9.4 Starting up the control and the burner

For further start-up steps, follow the burner start-up sequence. Refer to the → burner documentation.

Switch on the heating system with the control switch. The burner starts if a heat demand is present or if you switch the control panel to manual.

(→ Logamatic service manual).

- Select "Manual" operation
- Set the required temperature at the boiler water thermostat.
- Switch control on (position "I").

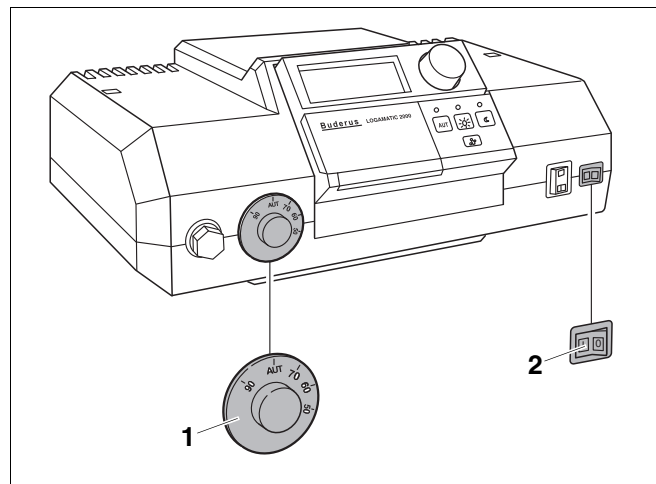

Fig. 59 Switching on the control (for example Logamatic 2000)

- 1 Boiler water thermostat
- 2 Main control switch

9.5 Guidelines for starting up the burner

Allow burner to operate for 15 to 20 minutes before a combustion test. Earlier combustion tests can lead to incorrect readings as a result of burning off the sealing rope. We recommend checking the burner after a few weeks of operation.



NOTICE

Incorrect burner adjustment can cause contamination of the boiler (e.g. soot). Faults may occur more often than normal.

Always check combustion with the following instruments.

Never adjust burner visually.

Required instruments:

- CO₂ measuring equipment
- Draft measuring equipment
- Oil pressure gauge
- Stack thermometer
- Smoke tester

9 Placing the boiler in operation

- Check the firebox pressure at the test port.
- Check the breeching draft at a test port drilled in the vent connector (chimney vent models only).

9.6 Raising flue gas temperature

For the set flue gas temperature for the boiler see the technical data (→ Chapter 2, page 6)

You may raise the flue gas temperature if you discover during tests that the flue gas temperature is too low for the type of chimney used (risk of condensation) by one or several of the following measures:

- Remove flue gas baffle plates
- Remove the flue gas check plate
- Shut down the heating system (→ Chapter 9.1, page 47).

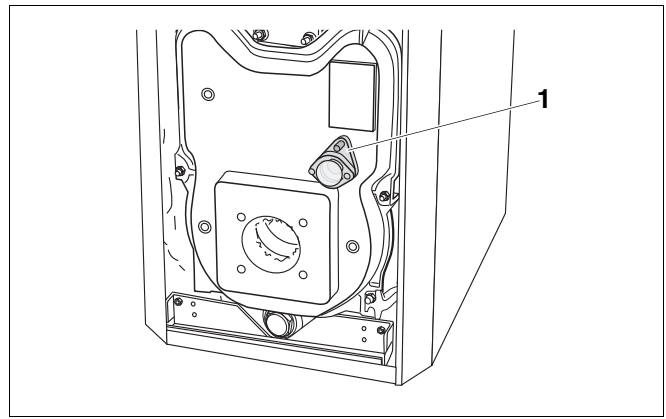

Fig. 60 Pressure test port on burner door

1 Pressure test port



WARNING!

RISK OF EXPLOSION

due to escaping gas.

- Shut off the main shut-off valve if the gas line to the gas burner must be disconnected to open the burner door. Route the remaining escaping gas outdoors.



CAUTION!

DANGER OF BURNS

by touching hot boiler parts.

- Wear appropriate protective gloves or use pliers.

9.6.1 Removing flue gas baffle plates

You can remove the baffle plates in pairs to raise the flue gas temperature.

- Open burner door by removing the two hexagon bolts on the sides.
- Remove the baffle plates towards the front.
- Close burner door with the two hexagon bolts (approx. 90 lbs/inch) Tighten the hexagon bolts evenly to properly seal the burner door.
- Re-check the flue gas temperature.

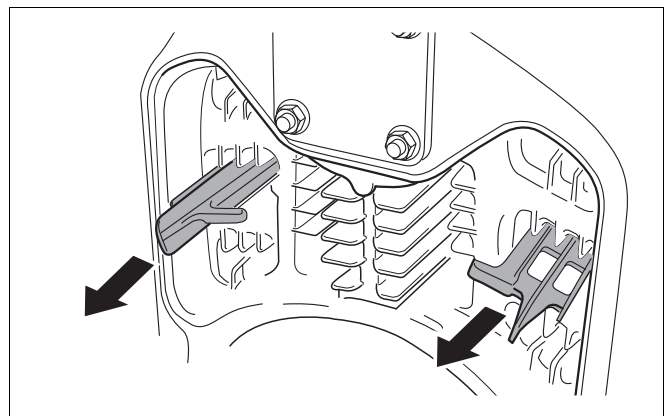

Fig. 61 Removing hot gas baffle plates (example: 2. hot gas flue)

9.6.2 Removing the blocking plate

You can remove the blocking plate to further raise the flue gas temperature if, after the removal of the hot gas baffle plates, the flue gas temperature is still too low.

- Open burner door by removing the two hexagon bolts on the sides.
- Remove blocking plate by loosening bolt.
- Re-check the flue gas temperature.

9.7 Checking the high Limit cut-out (STB)

The high limit cut-out interrupts the power supply if the maximum permissible flow temperature is exceeded. To enable a boiler reset and re-starting, the fault must be removed and the system must have fallen back below the limit.

- Check the high limit cut-out function (→ control device service instructions).

9.8 Installing jacket panels

- Attach burner door jacket in the slots of the front boiler cover.
- Slightly lift the burner door jacket until it hooks into the bottom cross bar.

- Hook in the decorative panel in the direction of the arrow.

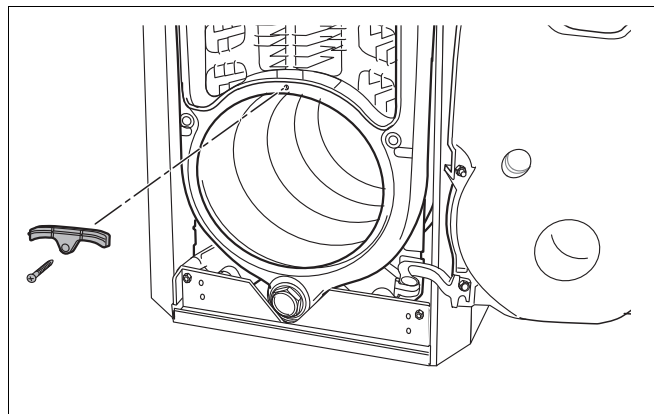

Fig. 62 Removing the blocking plate

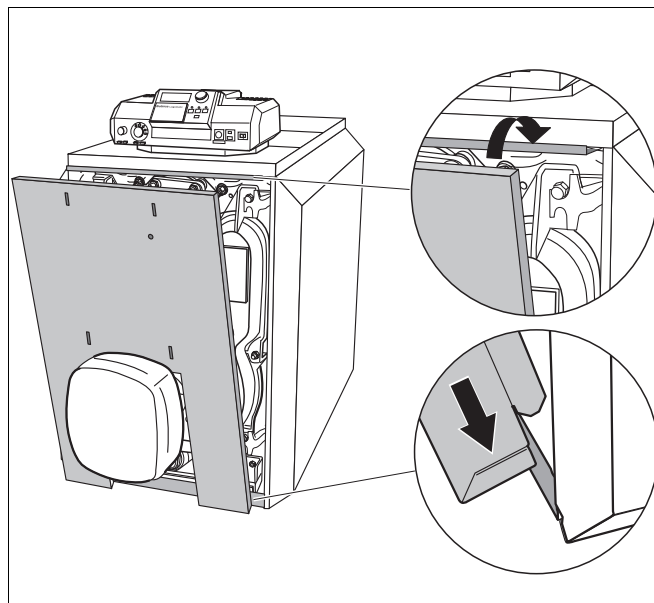

Fig. 63 Installing the burner door jacket

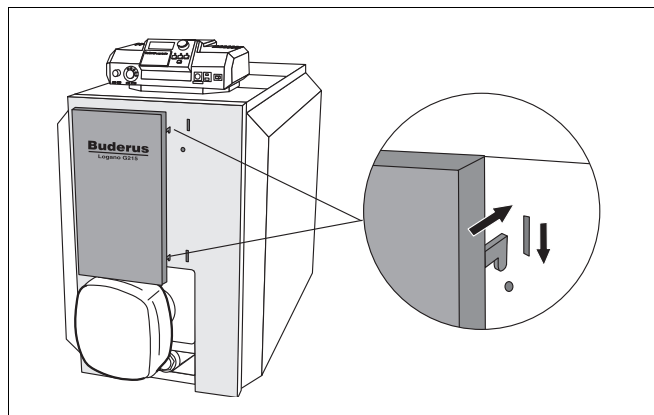

Fig. 64 Fitting the decorative panel

9.9 Start-up protocol

- Sign all start-up work as completed and enter the relevant date.

Start-up steps	Page	Value measured	Comments
1. Filling system and checking for leaks	35	<input type="checkbox"/> _____ psi	
2. Set operating pressure vent heating system check operation of pressure relief valve adjust the expansion tank pressure (→ see the expansion tank manufacturer's documentation)	42	<input type="checkbox"/> _____ psi	
3. Check combustion air and venting system		<input type="checkbox"/>	
5. Turn on control (→ refer to control service manual)	43	<input type="checkbox"/>	
6. Turn on burner (→ see burner manual)	43	<input type="checkbox"/>	
7. Measure flue gas temperature (adjust if required)	44	<input type="checkbox"/> _____ °F	
8. Check high limit cut-off (STB)	45	<input type="checkbox"/>	
9. Adjust the control settings to customer's requirements (→ control service manual)		<input type="checkbox"/>	
10. Inform end user and hand over instructions		<input type="checkbox"/>	
<p>Confirm start-up procedure</p> <p style="text-align: right;">Company stamp/signature/date</p>			

10 Taking the boiler out of operation

10.1 Normal boiler shut-down

- With Buderus Logamatic control: Switch the ON/OFF switch on the control panel OFF (position "0"). This switches the boiler and all its components OFF (for example the burner).

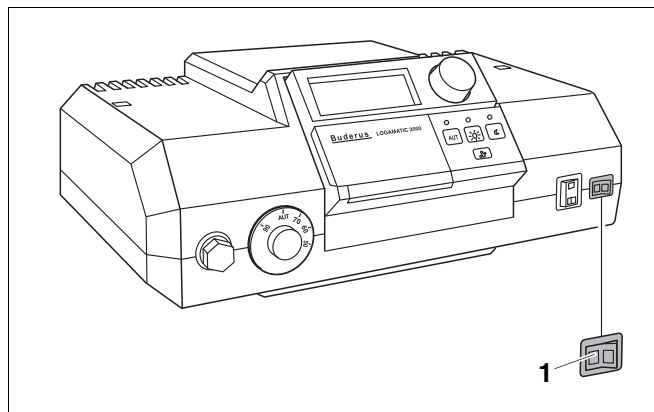

Fig. 65 Shutting down the heating system (Logamatic 2000)

1 ON/OFF switch

- When using the AquaSmart™ or HydroStat control: Shut off main heating system switch (position "OFF"). This switches off the boiler with all its components.
- Further shut-down procedure → refer to control documentation.
- Shut off fuel supply by closing main valve.



CAUTION!

SYSTEM DAMAGE

due to freezing temperatures.

The heating system can freeze up in cold weather if it has been switched off.

- Leave the heating system switched on as long as possible.
- Protect your heating system against freezing by draining the heating system and hot water pipes at the lowest possible point.

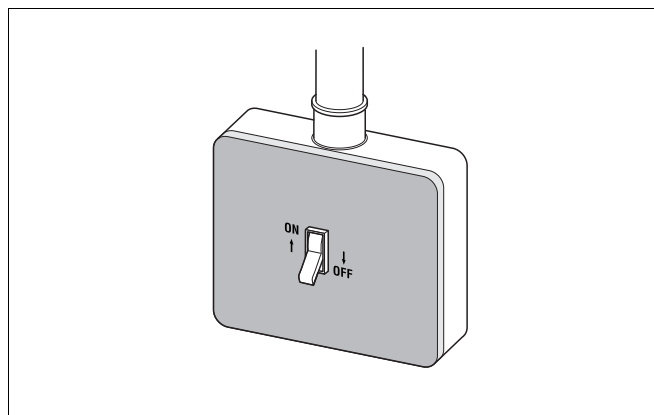

Fig. 66 Heating system shut-down (with AquaSmart™ and HydroStat)

10.2 Emergency shut-down

Explain to your customer the measures required in emergencies, for example in case of fire:

Proceed as follows in an emergency, such as a fire:

- Shut off fuel supply by closing main valve.
- Isolate the heating system from the electrical power supply via the heating system emergency stop switch or the building circuit-breaker.

11 Boiler maintenance

11.1 Why is regular maintenance important?

Heating systems should be regularly maintained for the following reasons:

- to achieve a high level of efficiency and to operate the system economically (low fuel consumption),
- to achieve a high level of operational reliability,
- to maintain the cleanest possible combustion.

Offer an annual inspection and maintenance contract (depending on requirements) to your customer. You can check in the inspection and maintenance reports (→ Chapter 10.6, page 52) what should be included in such contracts.



NOTICE

You may order spare parts from your local distributor.

11.2 Preparing the boiler for cleaning

- Shut down the heating system (→ Chapter 9.1, page 47).



WARNING!

DANGER TO LIFE

from electric shock.

- Before you open the control: shut off electrical supply and secure against accidental activation.
- Remove the burner door panel or the burner hood from the boiler.
- Disconnect electrical supply to burner.



WARNING!

DANGER TO LIFE

through the explosion of volatile gases.

- Work on gas components must be carried out by qualified and authorized personnel only.

11.3 Boiler cleaning

The boiler can be cleaned with brushes and/or by a wet method. Cleaning equipment is available as accessory.



CAUTION!

DANGER OF BURNS

by touching hot boiler parts.

- Wear appropriate protective gloves or use pliers.

- Open burner door by removing the two hexagon bolts on the sides.

11.3.1 Cleaning the boiler with cleaning brushes

- Note the position of the flue gas baffle plates to enable their correct re-installation later.
- Remove the flue gas baffle plates from the flue gas flues.
- Clean the flue gas baffle plates with one of the two cleaning brushes.

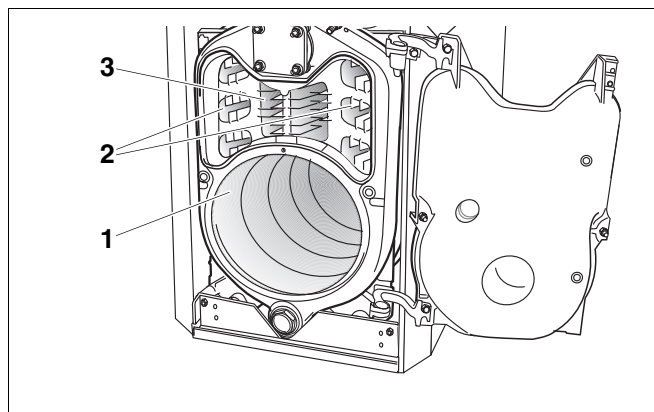

Fig. 67 Open the burner door

- 1 Combustion chamber
- 2 1. flue gas pass
- 3 2. flue gas pass

- Clean the flue passages by turning the round cleaning brush.

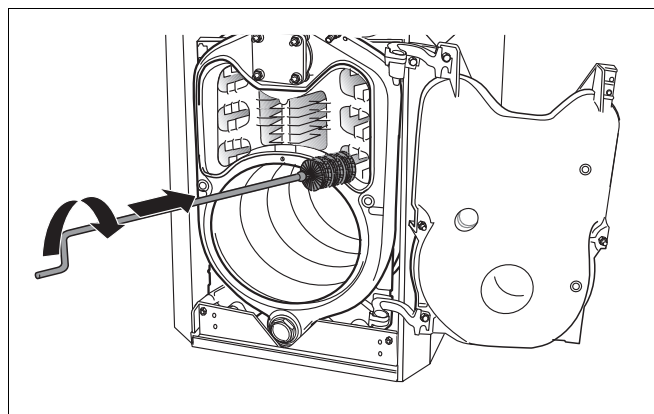

Fig. 68 Brushing out the flue gas passages

11 Boiler maintenance

- Clean the combustion chamber with a flat brush. Remove the debris from the combustion chamber, the flue passages and the flue connection.
- Install the flue baffle plates in their original position.
- Check sealing rope on burner door. Replace damaged or hardened sealing rope.



NOTICE

You can obtain suitable sealing rope from your local Buderus distributor.

- Close burner door with the two hexagon bolts (approx. 90 lbs/inch) Tighten the hexagon bolts evenly to properly seal the burner door.

11.3.2 Wet cleaning (chemical cleaning)

When using a wet cleaning method use a suitable cleaning agent (soot or accumulation of debris).

Proceed with the wet cleaning in the same order as described for cleaning with brushes (→Chapter 10.3.1, page 49).



NOTICE

Observe the instructions for use of the cleaning agent. You may need to proceed differently from the method described here in some circumstances.

- Cover the control panel with plastic to prevent spray from entering the control panel.
- Spray cleaning agent evenly into the flue gas passes.
- Close burner door and start up the heating system.
- Heat the boiler to a temperature of at least 160 °F.
- Shut down the heating system.
- Brush out the hot gas flues.

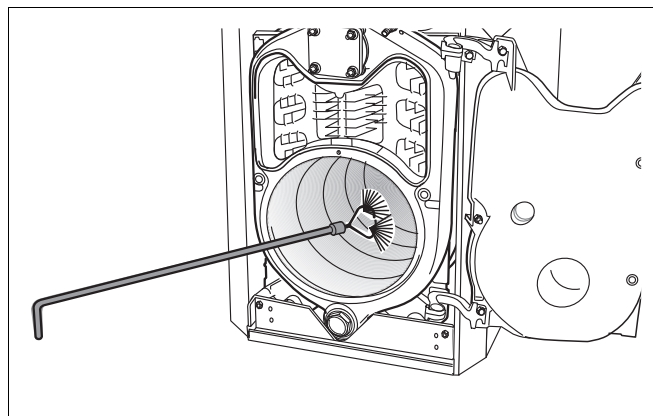

Fig. 69 Brushing out the combustion chamber

11.4 Checking the heating system operating pressure

The system pressure for closed systems must be 12 – 30 psi (1 – 2.1 bar).

- Check system pressure
- If the pressure gauge shows less than 12 psi, the pressure is too low. Top up with water.



CAUTION!

SYSTEM DAMAGE

due to frequent topping up.

If you need to add water frequently, the heating system may be damaged by corrosion and lime accumulation.

- Ensure that your heating system is bled properly.
- Check the heating system for leaks and proper operation of the expansion tank.



CAUTION!

SYSTEM DAMAGE

due to material stress as a result of temperature differentials.

- Only fill the system when cold (the flow temperature should be no more than 100 °F).

- Add water through the feed valve.
- Vent heating system
- Check the pressure again.

11.5 Testing relief valve

The functioning of the pressure relief valve must be checked at regular intervals (1-3 years as specified by local codes).

- Make sure that no persons are in the discharge area of the pressure relief valve.
- Raise the lever on the pressure relief valve.

The pressure relief valve must open and release pressure. If the pressure relief valve does not discharge, it must be replaced, because system components may be damaged by excessive pressure.

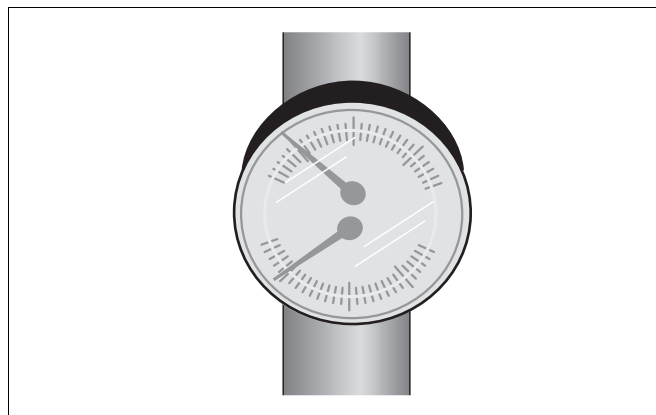

Fig. 70 Pressure/temperature gauge for showing operating pressure and feed temperature

11.6 Inspection and maintenance protocols

- Sign all service work as completed and enter the relevant date.

The service and maintenance protocols can also be used as templates.

	Service work	Page	Date: _____	Date: _____	Date: _____
1.	Check the general condition of the heating system		<input type="checkbox"/>	<input type="checkbox"/>	<input type="checkbox"/>
2.	Visual and function check of the heating system		<input type="checkbox"/>	<input type="checkbox"/>	<input type="checkbox"/>
3.	Check all fuel and water components of the system for: <ul style="list-style-type: none"> – leaks during operation – leak test – visible signs of corrosion – signs of ageing 		<input type="checkbox"/>	<input type="checkbox"/>	<input type="checkbox"/>
4.	Check the combustion chamber and the heating surface for contamination; shut down the system for this step	48	<input type="checkbox"/>	<input type="checkbox"/>	<input type="checkbox"/>
5.	Check the burner (→ burner manual)		<input type="checkbox"/>	<input type="checkbox"/>	<input type="checkbox"/>
6.	Check the combustion air supply and flue gas routing for function and safety		<input type="checkbox"/>	<input type="checkbox"/>	<input type="checkbox"/>
7.	Check the operating pressure, relief valve and expansion tank inlet pressure	51	<input type="checkbox"/>	<input type="checkbox"/>	<input type="checkbox"/>
8.	Check the DHW tank and corrosion anode for function (→ DHW tank documentation)		<input type="checkbox"/>	<input type="checkbox"/>	<input type="checkbox"/>
9.	Check the control settings (→ control manual)		<input type="checkbox"/>	<input type="checkbox"/>	<input type="checkbox"/>
10.	Record the final checks of the inspection work, incl. measurements and test results		<input type="checkbox"/>	<input type="checkbox"/>	<input type="checkbox"/>
	Confirm service work				
			Company stamp/signature	Company stamp/signature	Company stamp/signature

	Date: _____	Date: _____	Date: _____	Date: _____	Date: _____	Date: _____	Date: _____
1.	<input type="checkbox"/>	<input type="checkbox"/>	<input type="checkbox"/>	<input type="checkbox"/>	<input type="checkbox"/>	<input type="checkbox"/>	<input type="checkbox"/>
2.	<input type="checkbox"/>	<input type="checkbox"/>	<input type="checkbox"/>	<input type="checkbox"/>	<input type="checkbox"/>	<input type="checkbox"/>	<input type="checkbox"/>
3.	<input type="checkbox"/>	<input type="checkbox"/>	<input type="checkbox"/>	<input type="checkbox"/>	<input type="checkbox"/>	<input type="checkbox"/>	<input type="checkbox"/>
4.	<input type="checkbox"/>	<input type="checkbox"/>	<input type="checkbox"/>	<input type="checkbox"/>	<input type="checkbox"/>	<input type="checkbox"/>	<input type="checkbox"/>
5.	<input type="checkbox"/>	<input type="checkbox"/>	<input type="checkbox"/>	<input type="checkbox"/>	<input type="checkbox"/>	<input type="checkbox"/>	<input type="checkbox"/>
6.	<input type="checkbox"/>	<input type="checkbox"/>	<input type="checkbox"/>	<input type="checkbox"/>	<input type="checkbox"/>	<input type="checkbox"/>	<input type="checkbox"/>
7.	<input type="checkbox"/>	<input type="checkbox"/>	<input type="checkbox"/>	<input type="checkbox"/>	<input type="checkbox"/>	<input type="checkbox"/>	<input checked="" type="checkbox"/>
8.	<input type="checkbox"/>	<input type="checkbox"/>	<input type="checkbox"/>	<input type="checkbox"/>	<input type="checkbox"/>	<input type="checkbox"/>	<input type="checkbox"/>
9.	<input type="checkbox"/>	<input type="checkbox"/>	<input type="checkbox"/>	<input type="checkbox"/>	<input type="checkbox"/>	<input type="checkbox"/>	<input type="checkbox"/>
10.	<input type="checkbox"/>	<input type="checkbox"/>	<input type="checkbox"/>	<input type="checkbox"/>	<input type="checkbox"/>	<input type="checkbox"/>	<input type="checkbox"/>
	Company stamp/signature	Company stamp/signature	Company stamp/signature	Company stamp/signature	Company stamp/signature	Company stamp/signature	Company stamp/signature



NOTICE

During the inspection if you identify any required maintenance steps, do it as soon as possible.

11 Boiler maintenance

	On-demand maintenance procedures	Page	Date: _____	Date: _____	Date: _____
1.	Shut down the heating system	47	<input type="checkbox"/>	<input type="checkbox"/>	<input type="checkbox"/>
2.	Remove and clean the flue baffles	49	<input type="checkbox"/>	<input type="checkbox"/>	<input type="checkbox"/>
3.	Clean the (heating surfaces) and combustion chamber, then re-install the flue baffle plates in their original position.	49	<input type="checkbox"/>	<input type="checkbox"/>	<input type="checkbox"/>
4.	Check and, if required, replace gaskets/sealing rope on the burner door and burner	50	<input type="checkbox"/>	<input type="checkbox"/>	<input type="checkbox"/>
5.	Start up the heating system	43	<input type="checkbox"/>	<input type="checkbox"/>	<input type="checkbox"/>
6.	Carry out final check of the maintenance work		<input type="checkbox"/>	<input type="checkbox"/>	<input type="checkbox"/>
7.	Check the function and safety in operation		<input type="checkbox"/>	<input type="checkbox"/>	<input type="checkbox"/>
	Confirm professional maintenance				
			Company stamp/signature	Company stamp/signature	Company stamp/signature

	Date: _____	Date: _____	Date: _____	Date: _____	Date: _____	Date: _____	Date: _____
1.	<input type="checkbox"/>	<input type="checkbox"/>	<input type="checkbox"/>	<input type="checkbox"/>	<input type="checkbox"/>	<input type="checkbox"/>	<input type="checkbox"/>
2.	<input type="checkbox"/>	<input type="checkbox"/>	<input type="checkbox"/>	<input type="checkbox"/>	<input type="checkbox"/>	<input type="checkbox"/>	<input type="checkbox"/>
3.	<input type="checkbox"/>	<input type="checkbox"/>	<input type="checkbox"/>	<input type="checkbox"/>	<input type="checkbox"/>	<input type="checkbox"/>	<input type="checkbox"/>
4.	<input type="checkbox"/>	<input type="checkbox"/>	<input type="checkbox"/>	<input type="checkbox"/>	<input type="checkbox"/>	<input type="checkbox"/>	<input type="checkbox"/>
5.	<input type="checkbox"/>	<input type="checkbox"/>	<input type="checkbox"/>	<input type="checkbox"/>	<input type="checkbox"/>	<input type="checkbox"/>	<input type="checkbox"/>
6.	<input type="checkbox"/>	<input type="checkbox"/>	<input type="checkbox"/>	<input type="checkbox"/>	<input type="checkbox"/>	<input type="checkbox"/>	<input type="checkbox"/>
7.	<input type="checkbox"/>	<input type="checkbox"/>	<input type="checkbox"/>	<input type="checkbox"/>	<input type="checkbox"/>	<input type="checkbox"/>	<input type="checkbox"/>
	Company stamp/signature	Company stamp/signature	Company stamp/signature	Company stamp/signature	Company stamp/signature	Company stamp/signature	Company stamp/signature

12 Troubleshooting

Two different types of faults are defined

- Burner faults and
- control and heating system faults.

If there is a burner fault the alarm light on the burner comes on (→ burner manual). Such faults can generally be reset by pressing the reset button on the burner only once.

Control and heating system faults are indicated on the control display if it is fitted with a display. For further information see → control manual.

Correcting burner faults

- Remove the burner hood if the boiler is equipped with an integral burner.
- Press reset button on burner only once.



CAUTION!

SYSTEM DAMAGE

due to freezing temperatures.

The heating system can freeze up in cold weather if it has been switched off by a fault shutdown.

- Immediately remedy the fault and restart the heating system.
- If this is not possible, protect your heating system against freezing by draining the heating system and hot water pipes at the lowest possible point.

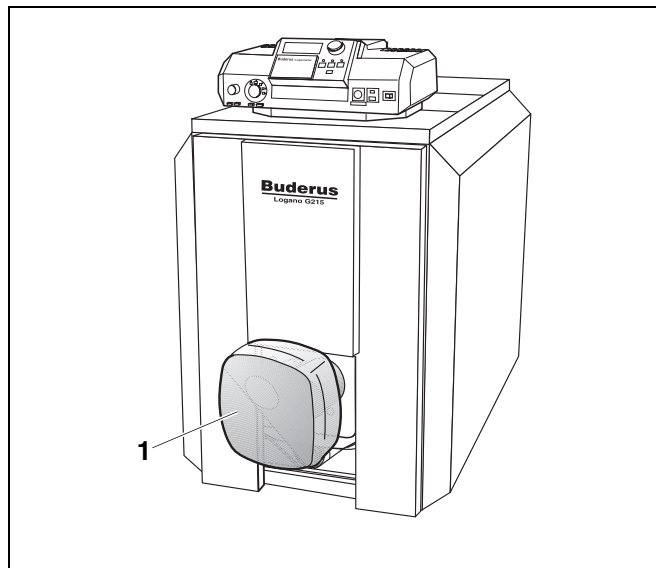

Fig. 71 Resetting the burner

1 Burner

13 Examples of installations

Explanation of abbreviations

- | | | | |
|-----|-------------------------|-----|---|
| KR | Check valve | SH | Mixing valve |
| MAG | Expansion tank | SR | Adjustment for raising return temperature |
| PH | System pump | SV | Air scoop |
| PW | Domestic hot water pump | THV | Zone valve |
| | | WH | Pressure bypass loop |

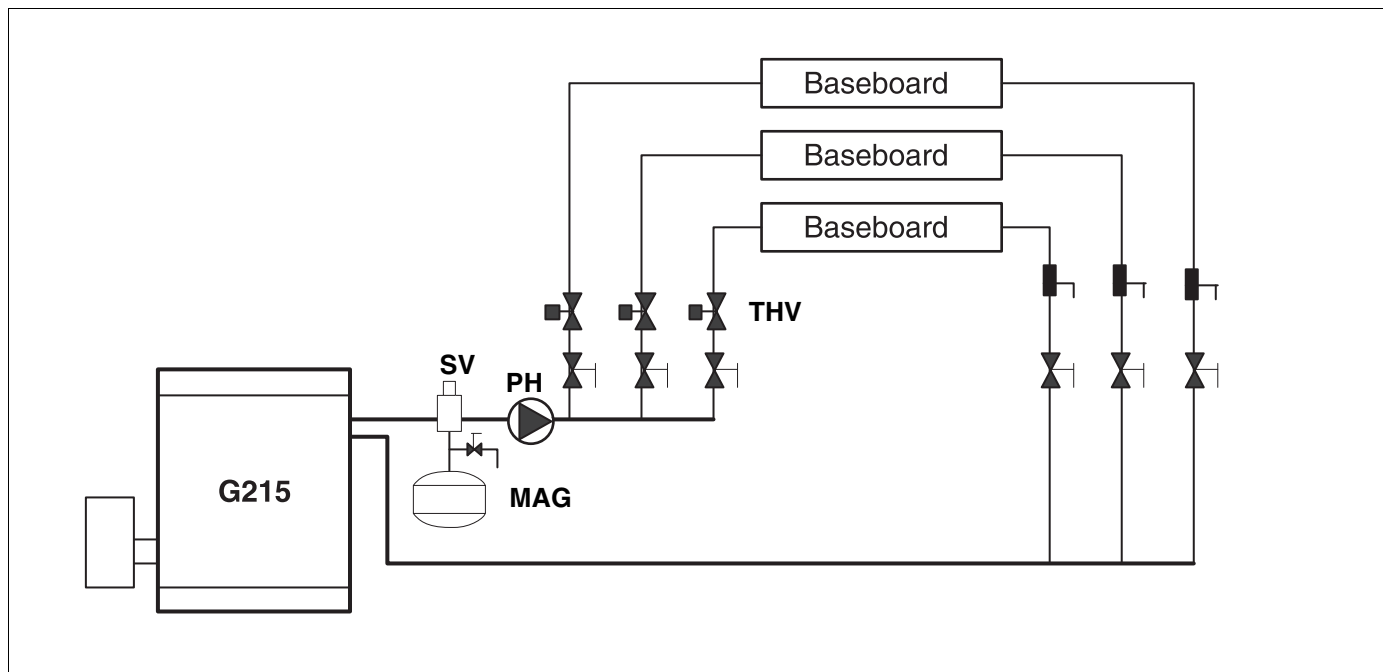

Fig. 72 Multiple circuits with circuit valves

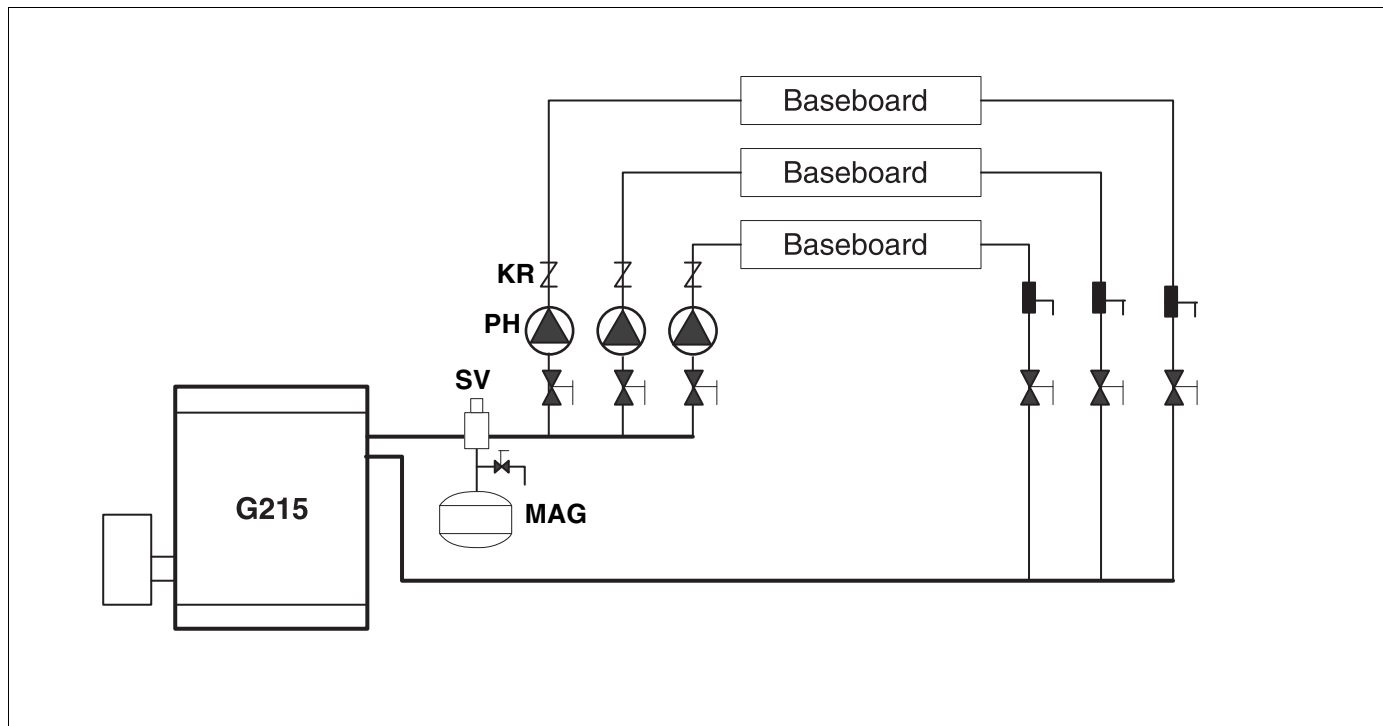

Fig. 73 Multiple circuits with circuit valves

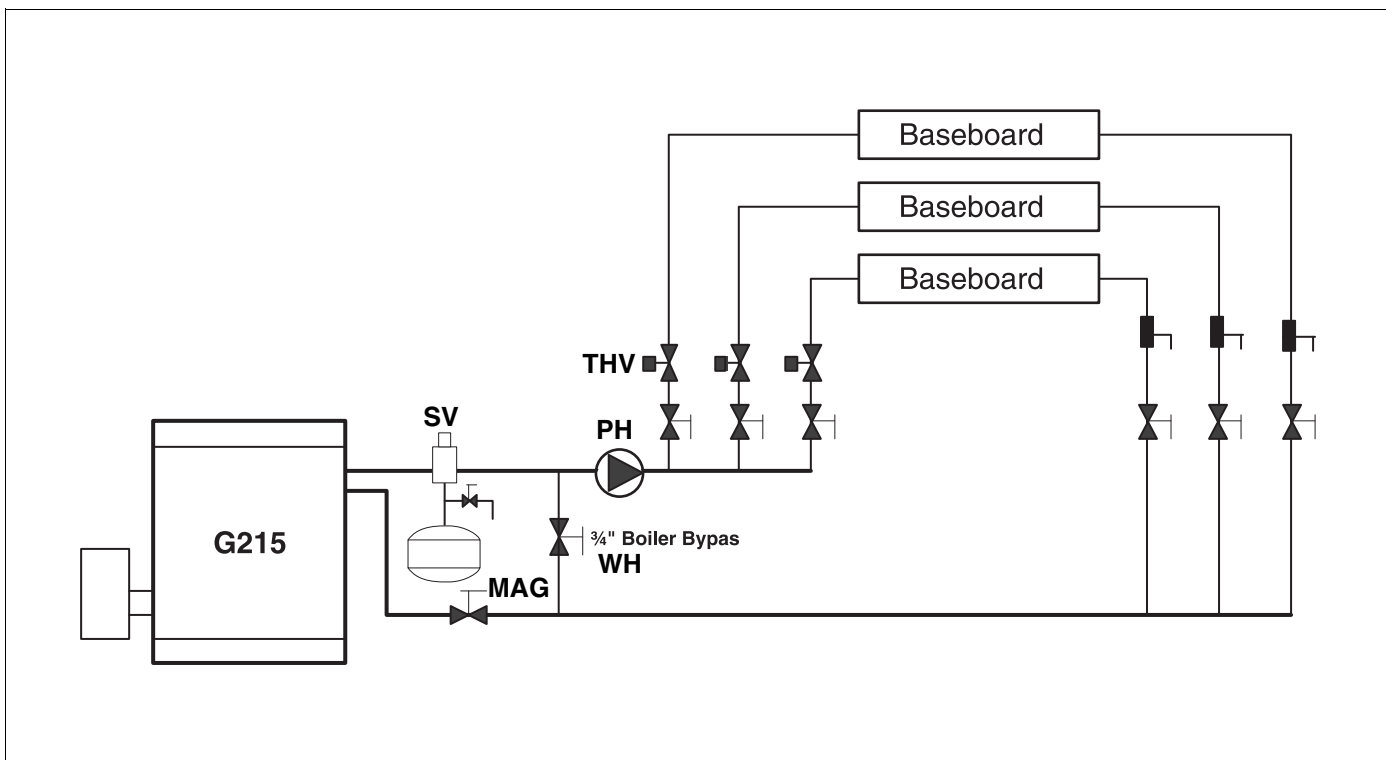

Fig. 74 Multiple circuits of water diversion for systems with a high water volume

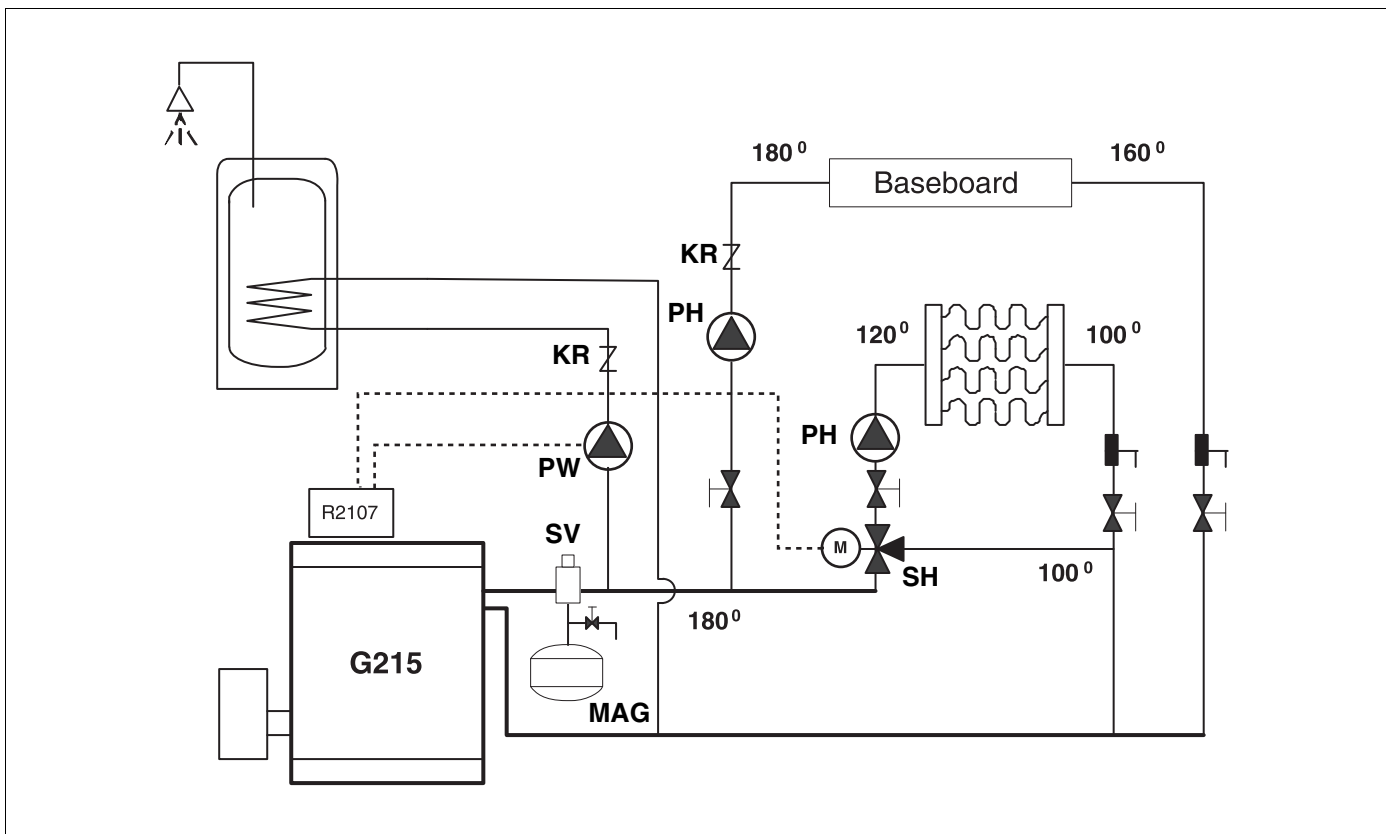

Fig. 75 Multiple circuits with pumps and motor-actuated 3-way mixing valve

14 Circuit diagrams

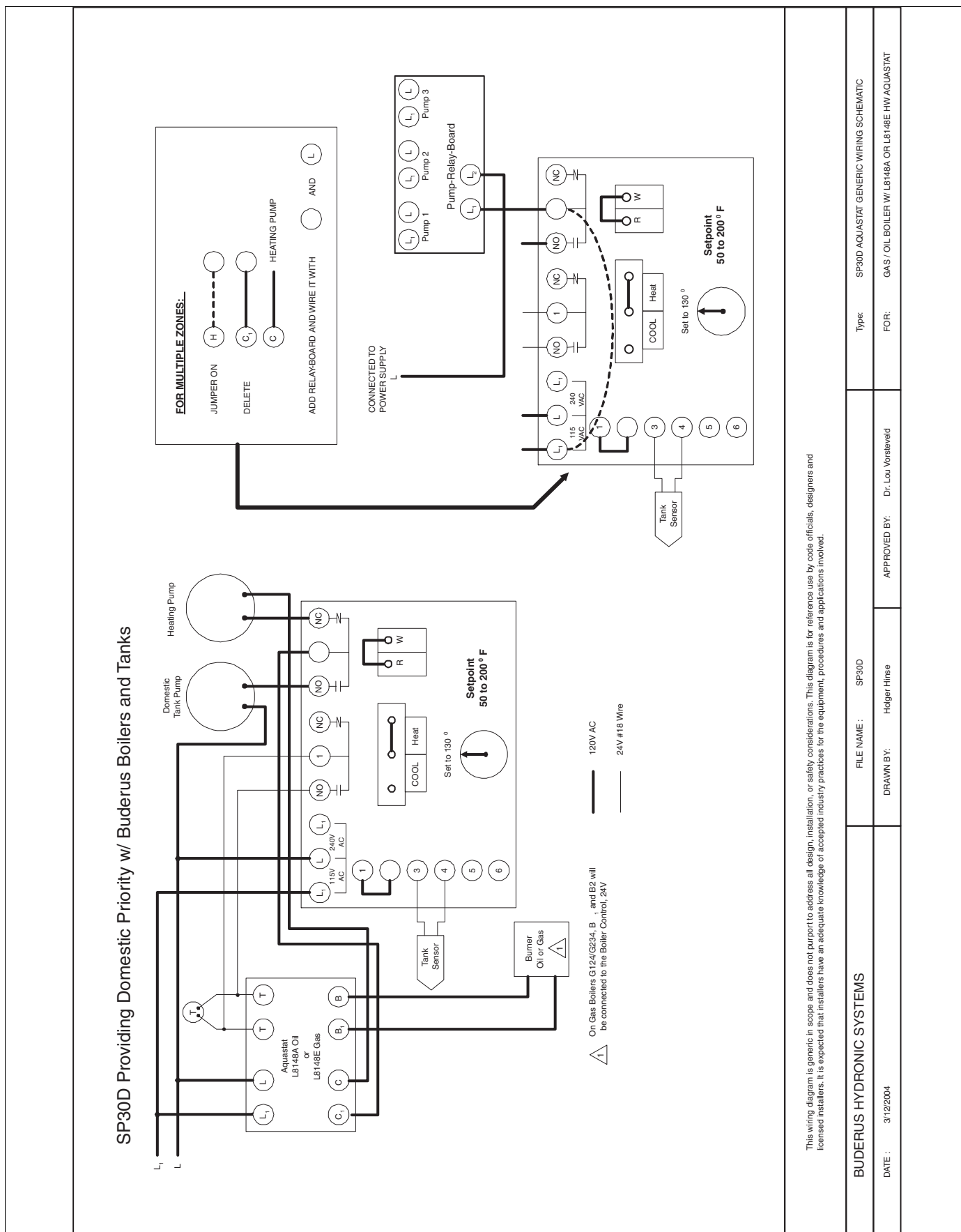
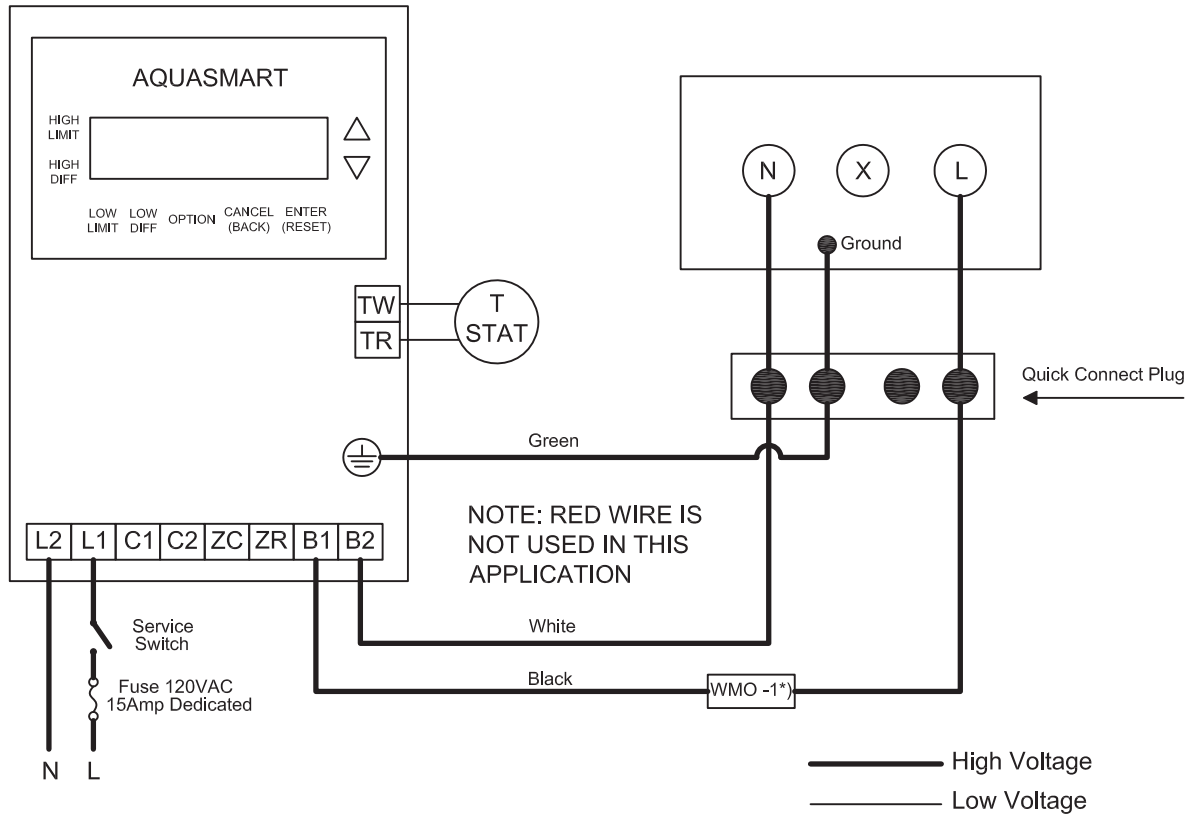

Fig. 76 Circuit diagram 1

This wiring diagram is generic in scope and does not purport to address all design, installation, or safety considerations. This diagram is for reference use by code officials, designers and licensed installers. It is expected that installers have an adequate knowledge of accepted industry practices for the equipment, procedures and applications involved.

BUDERUS HYDRONIC SYSTEMS		FILE NAME :	SP30D
DATE :	3/12/2004	DRAWN BY :	Hölger Hense
		APPROVED BY :	Dr. Lou Vorsteveld
		Type:	SP30D AQUASTAT GENERIC WIRING SCHEMATIC
		FOR:	GAS / OIL BOILER W/ L8148A OR L8148E HW AQUASTAT

Riello F3 and F5 Series Oil Burner Wiring



Riello F3 or F5 Oil Fired Burner

Using a Beckett Aquasmart Aquastat -

- 1) Connect room thermostat or end switch to the TW and TR terminals of the AQUASMART
- 2) Connect incoming 120VAC power source to L1 on the AQUASMART
- 3) Connect incoming neutral to L2 on the AQUASMART
- 4) Connect black wire to B1 on the AQUASMART and to L on the Riello terminal block.
- 5) Connect white wire to B2 on the AQUASMART and to N on the Riello terminal block.
- 6) Connect green wire to ground screw on AQUASMART to the ground connection on the Riello burner.
- 7) Red wire is not used in this application.

*) Canadian Installations: Install in series with start wire to burner (phase).

Fig. 77 Circuit diagram 2

Carlin EZ-1 HP Oil Burner Wiring

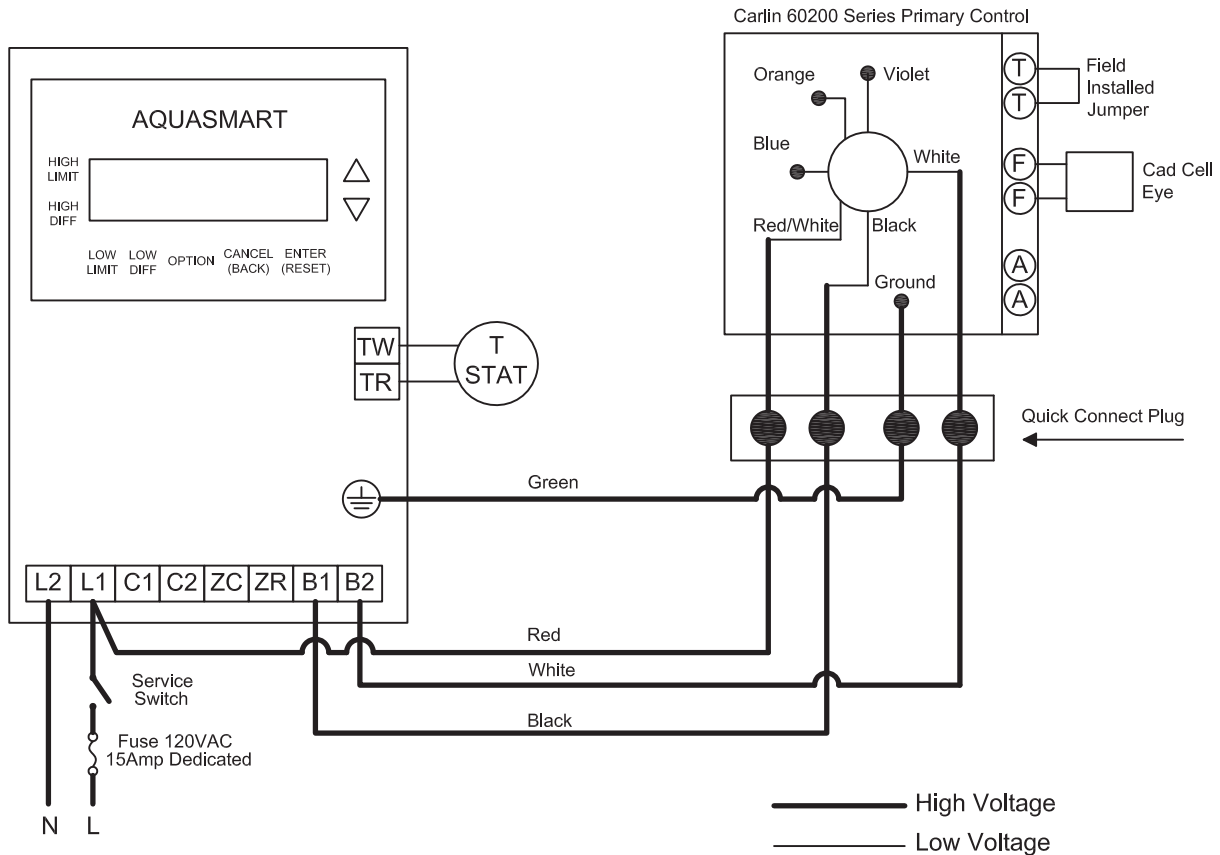

Carlin EZ-1 HP Oil Fired Burner

Using a Beckett Aquasmart Aquastat -

- 1) Connect room thermostat or end switch to the TW and TR terminals of the AQUASMART
NOTE: DO NOT CONNECT ROOM THERMOSTAT OR END SWITCH TO T-T ON CARLIN 60200 CONTROL

- 2) Connect incoming 120VAC power to L1 on the AQUASMART
- 3) Connect incoming neutral to L2 on the AQUASMART
- 4) Connect red wire to L1 on the AQUASMART and to the red/white wire on the Carlin 60200 control.
- 5) Connect black wire to B1 on the AQUASMART and to the black wire on the Carlin 60200 control.
- 6) Connect white wire to B2 on the AQUASMART and to the white wire on the Carlin 60200 control.
- 7) Connect green wire to ground screw on AQUASMART to the ground connection on the Riello burner.
- 8) Install a jumper between T-T terminals on the Carlin 60200 control.
- 3) The pink wire from the Carlin "in line heater" may be connected to the red/white and white wire in the Carlin 60200 control.

:

Fig. 78 Circuit diagram 3

Beckett AFG or NX Oil Fired Burner Wiring

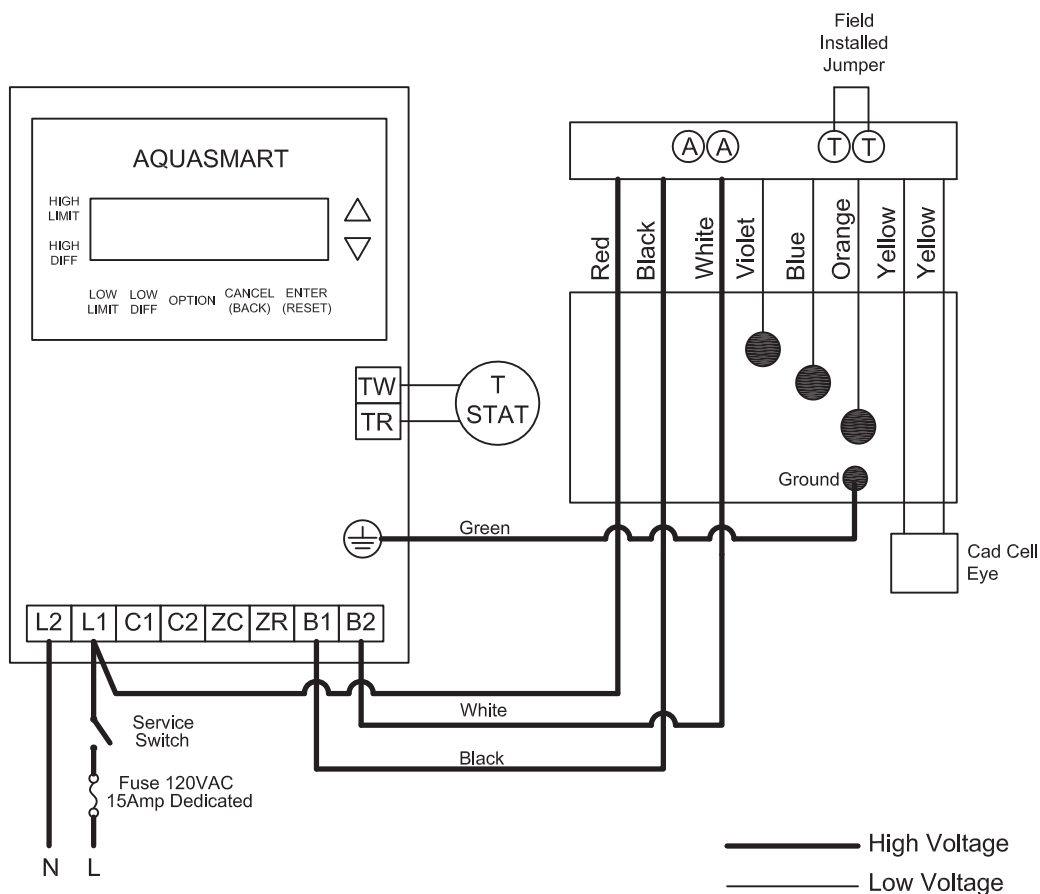

Beckett AFG or NX Oil Fired Burner

Using a Beckett Aquasmart Aquastat -

1) Connect room thermostat or end switch to the TW and TR terminals of the AQUASMART.

NOTE: DO NOT CONNECT ROOM THERMOSTAT OR END SWITCH TO T-T ON HONEYWELL R7148B OR GENISYS 7505B CONTROL

2) Connect incoming 120VAC power source to L1 on the AQUASMART

3) Connect incoming neutral to L2 on the AQUASMART

4) Connect red wire to L1 on the AQUASMART and to the red wire on the R7148B or Genisys 7505B control.

5) Connect black wire to B1 on the AQUASMART and to the Black wire on the R7148B or Genisys 7505B control.

6) Connect white wire to B2 on the AQUASMART and to the White wire on the R7148B or Genisys 7505B control.

7) Connect green wire to ground screw on AQUASMART to the ground connection on the R7148B or Genisys 7505B control.

8) Install a jumper between terminals T-T.

Fig. 79 Circuit diagram 4

Beckett AFG or NX Oil Fired Burner Wiring

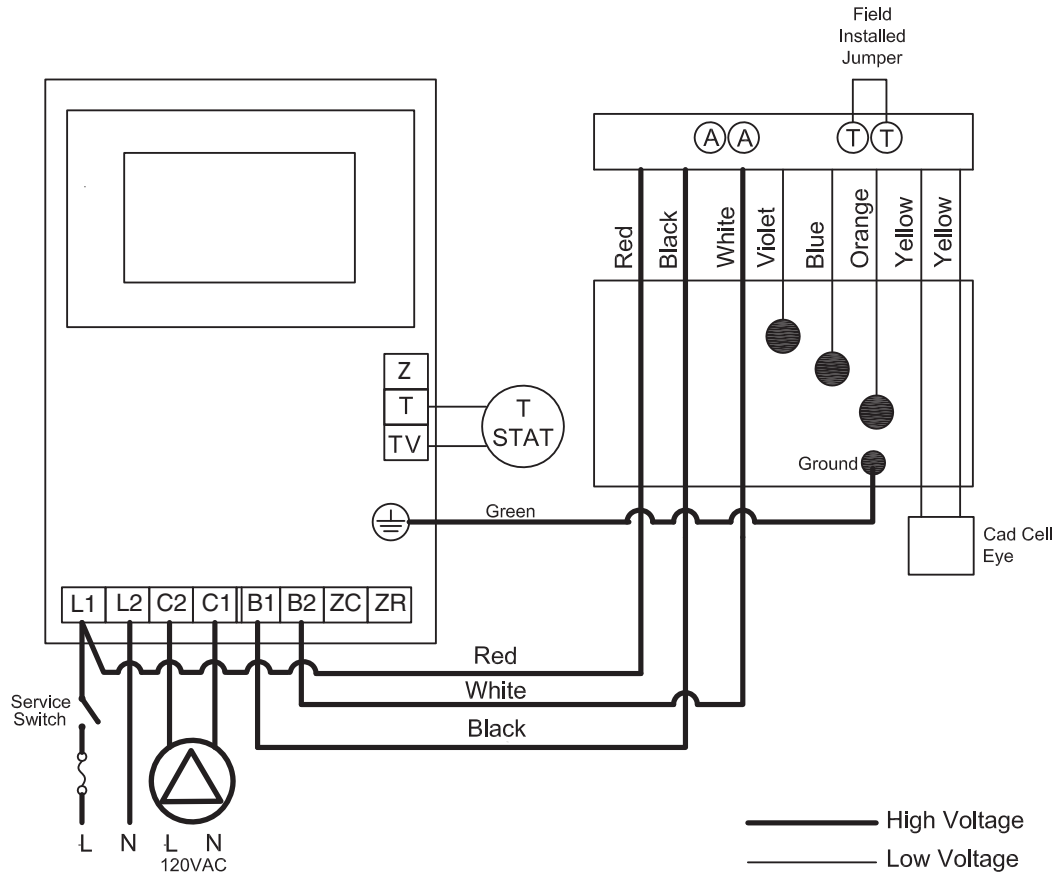

Beckett AFG or NX Oil Fired Burner

Using Hydrolevel HydroStat with Honeywell R7148B or Genisys 7505B

1. Connect room thermostat or end switch to T and TV terminals on control.
2. Connect incoming 120VAC power source to the control.
3. Connect Line Voltage to terminal L1, and Neutral to terminal L2.
4. Connect the black wire from the Honeywell or Genisys to terminal B1 on control.
5. Connect the white wire from the Honeywell or Genisys to terminal B2 on control.
6. Connect the green wire from Honeywell or Genisys to ground screw on control.
7. Connect the red wire from the Honeywell or Genisys to L1 on control.
8. Install a jumper between TT on Honeywell or Genisys.

NOTE: Do not connect a room thermostat or end switch to TT on the Honeywell R7148B or Genisys 7505B control.

6 720 813 418-03.1T

Fig. 80 Boiler block and burner door

Carlin EZ-1 HP Oil Burner Wiring

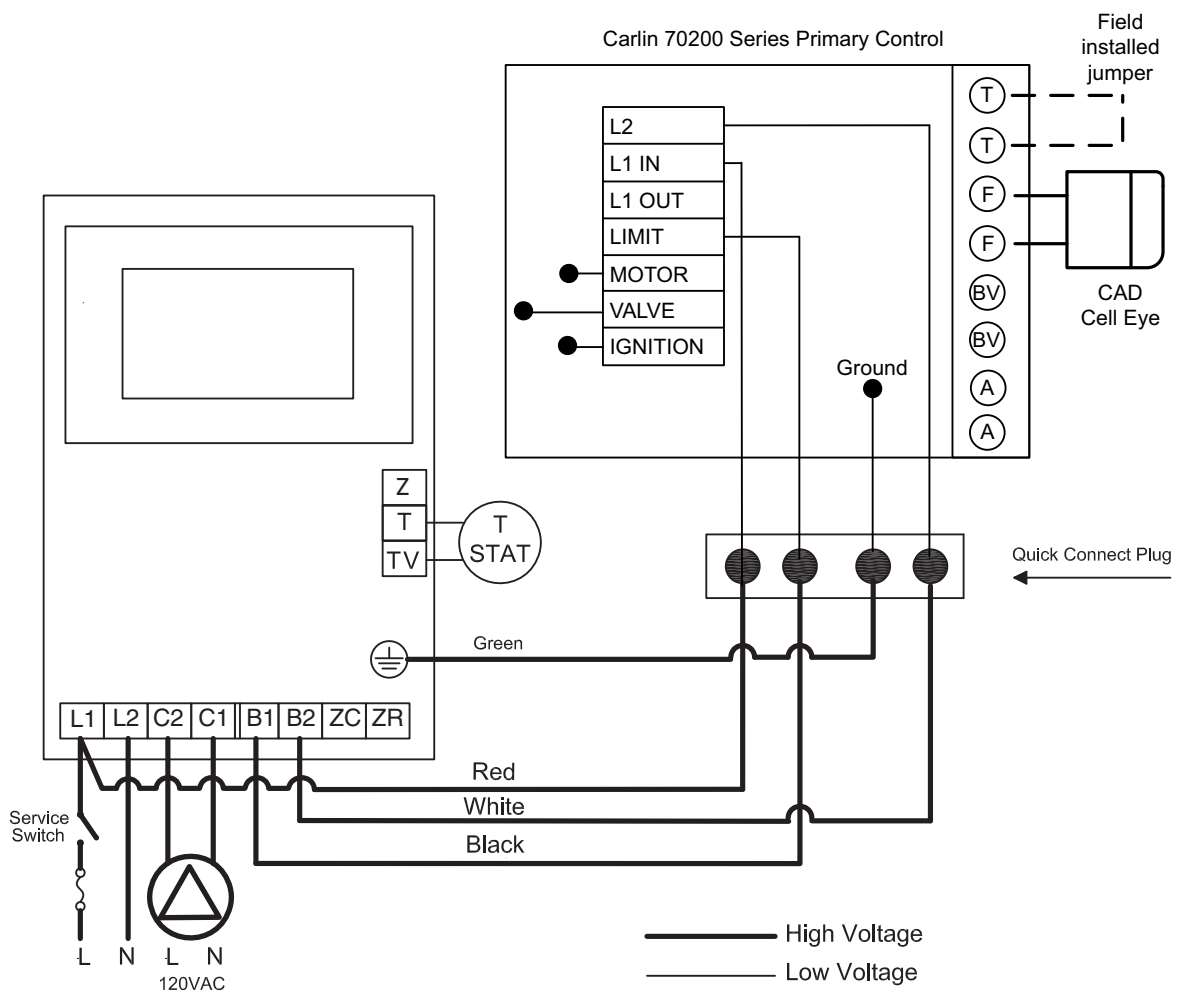

Carlin EZ-1 HP Oil Fired Burner

Using Hydrolevel HydroStat

1. Connect room thermostat or end switch to T and TV terminals on control.
2. Connect incoming 120VAC power source to the control.
3. Connect Line Voltage to terminal L1, and Neutral to terminal L2.
4. Connect the black wire from the Carlin 70200 to terminal B1 on control.
5. Connect the white wire from the Carlin 70200 to terminal B2 on control.
6. Connect the green wire from Carlin 70200 to ground screw on control.
7. Install a jumper between TT on Carlin 70200.

6 720 813 418-04.1T

Fig. 81 Boiler block and burner door

Riello F3 and F5 Series Oil Burner Wiring

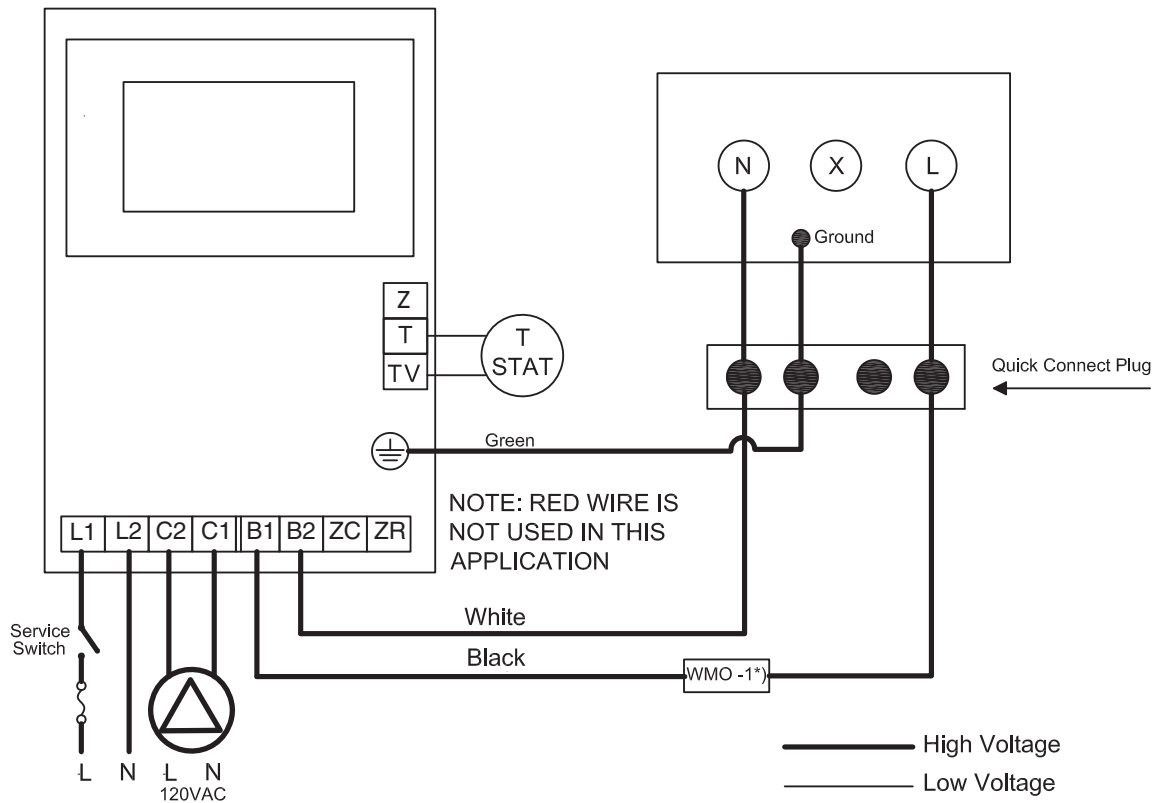

Riello F3 or F5 Oil Fired Burner

Using Hydrolevel HydroStat

1. Connect room thermostat or end switch to T and TV terminals on control.
2. Connect incoming 120VAC power source to the control.
3. Connect Line Voltage to terminal L1, and Neutral to terminal L2.
4. Connect the black wire from the Riello to terminal B1 on control.
5. Connect the white wire from the Riello to terminal B2 on control.
6. Connect the green wire from Riello to ground screw on control.
7. Install a jumper between TT on Riello.

6 720 813 418-05.1T

Fig. 82 Boiler block and burner door

Bosch Thermotechnology Corporation
50 Wenworth Avenue
Londonherry, NH 03053
Tel. 603-552-1100
Fax 603-584-1681
www.buderus.net

Products manufactured by
Bosch Thermotechnik GmbH
D-35573 Wetzlar
www.buderus.de

BTT North America Corporation reserves the right
to make changes without notice due to continuing
engineering and technological advances.

Buderus