

Installation Instructions

Gas Conversion Kit



For models: 250 SX, 250 SXO, GWH 2400 E, GWH 2400 EO, GWH 635 ES, GWH 635 ESO, GWH 715ES, GWH 2700 ES, GWH 2400 ES, Evolution 500, 830ES, 940ES, 940ESO

Part. no 8 719 002 176 0

Warning: This kit shall be installed by a qualified service agency in accordance with these instructions and all applicable codes and requirements of the authorities having jurisdiction.



BOSCH



1 Gas Type Conversion

For models: 250SX, 250SXO, GWH 635 ES, GWH 635 ESO, GWH 2400 E, GWH 2400 EO only

 **LP AND NG ARE EXTREMELY FLAMMABLE SO TAKE EXTRA PRECAUTIONS WHEN PERFORMING ANY WORK TO THE HEATER.**

 **PROCEDURE MUST BE PERFORMED BY A LICENSED GAS TECHNICIAN.**

A. Preparation

- ▶ 1. Tools needed:
 - flat and Phillips screwdrivers
 - #40 Torx driver
 - digital combustion analyzer
- ▶ 2. Turn power switch to off position and unplug water heater.
- ▶ 3. Remove cover.
- ▶ 4. Remove control board access cover (Fig. 1).

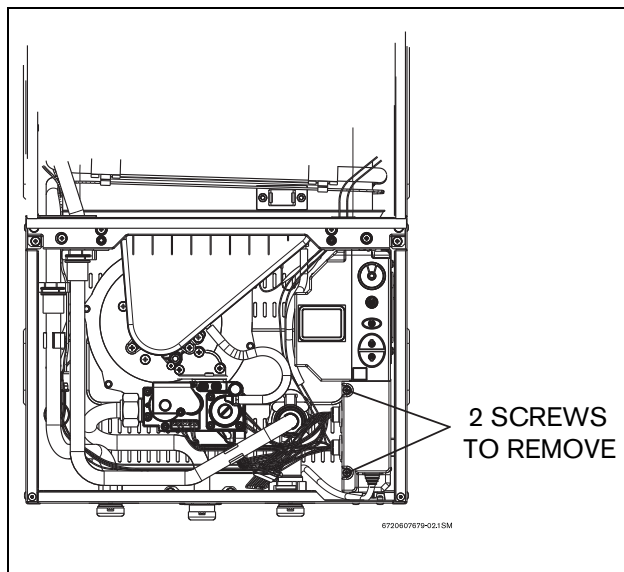

Fig. 1

- ▶ 5. Remove lower wire harness from control board.
- ▶ 6. Loosen yellow painted Philips screw and cover should rotate down revealing a brass slotted screw (Fig. 2).

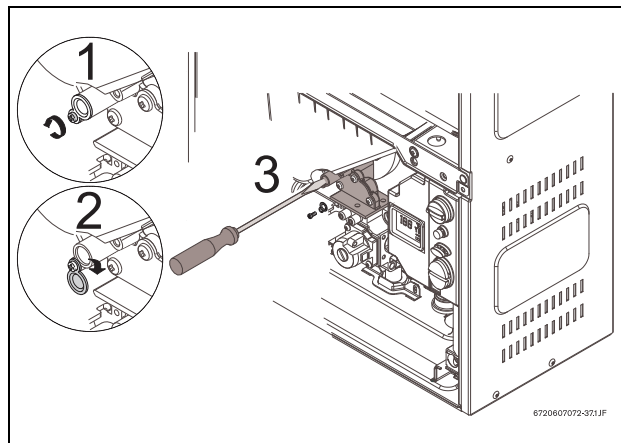

Fig. 2

- ▶ 7. Remove yellow painted # 40 Torx cover from the front of the gas valve revealing a plastic #40 Torx screw (Fig. 3).

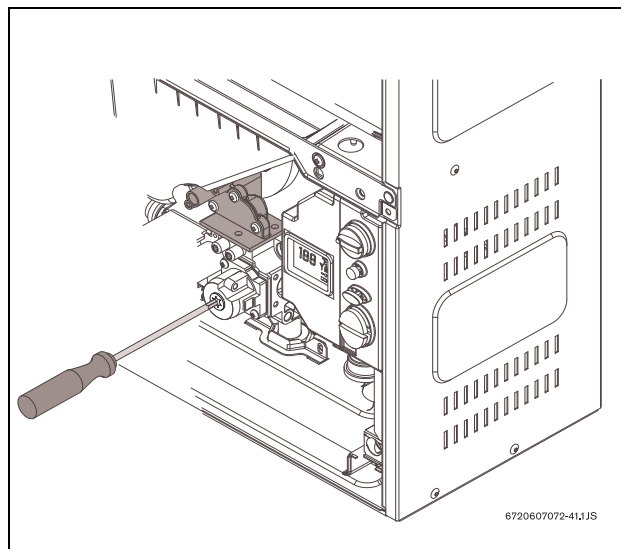

Fig. 3

B. Converting from LPG to NG

- ▶ 1. Add jumper to location JP6 on the control board (Fig. 4).

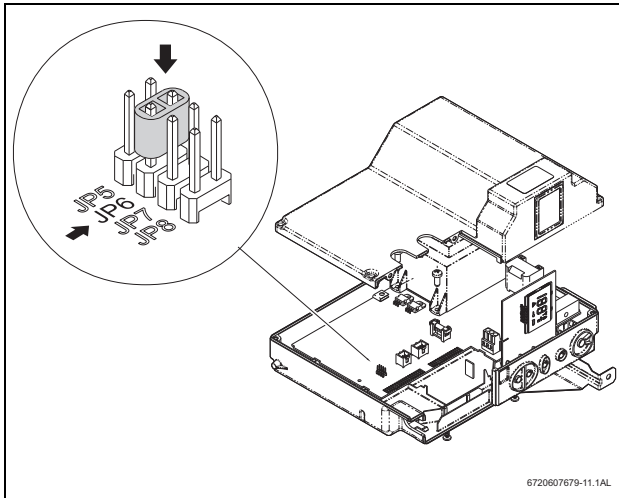

Fig. 4

- ▶ 2. Turn slotted brass screw 3.5 turns counter clockwise (Fig. 2).
- ▶ 3. Turn #40 plastic torx screw 1 tooth clockwise (Fig. 3).
- ▶ 4. Adjust CO2 (see chapter 2).

C. Converting from NG to LPG

- ▶ 1. remove jumper from location JP6 on the control board (Fig. 4).
- ▶ 2. Turn slotted brass screw 3.5 turns clockwise (Fig. 2).
- ▶ 3. Turn #40 plastic torx screw 1 tooth counter clockwise (Fig. 3).
- ▶ 4. Adjust CO2 (see chapter 2).

D. Clean up

- ▶ 1. Reinstall yellow painted #40 Torx cover on the front of gas valve (Fig. 3).
- ▶ 2. Rotate brass slotted screw cover up and tighten yellow painted Philips screw (Fig. 2).
- ▶ 3. Reinstall lower wire harness onto control board.
- ▶ 4. Reinstall control board access cover (Fig. 1).
- ▶ 5. Apply conversion sticker to right side panel above rating plate. Ensure information is filled out accurately.
- ▶ 6. Reinstall cover and return to service.

2 Measuring and adjusting CO₂ levels

The CO₂ can only be adjusted by a certified gas technician with a calibrated CO₂ analyzer.



Caution: One factor that may affect CO₂ levels is improper gas pressure. Please see Chapter 2.12 of manual for the procedure to measure gas pressure and record your findings below:

Static Gas Pressure: " WC

P1 Operating Pressure: " WC

The P1 minimum operating pressure is 5" WC for Natural Gas and 11"WC for Propane. Do not proceed in adjusting CO₂ until pressure is at or above these levels, but not to exceed 14" WC.

A. Once Pressure is adequate

- ▶ Turn ON/OFF switch to the OFF (O) position.
- ▶ Remove brass flat head screw on the exhaust collar, see Fig. 5.
- ▶ Insert CO₂ analyzer probe into the measuring port. Avoid air gaps between probe and measuring port. The tip of the probe should be in the center of the flue pipe (approx 1.5" inserted).

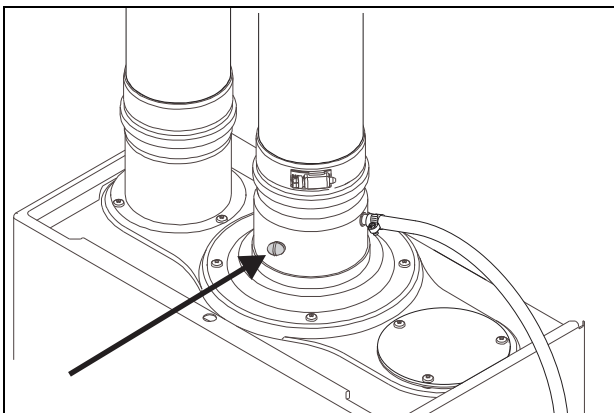

Fig. 5

- ▶ While holding in the Program (P) button, turn the ON/OFF switch to ON (I) position (see Fig. 6). As soon as '188' flashes on the display, release the Program button. The display should now read P2.

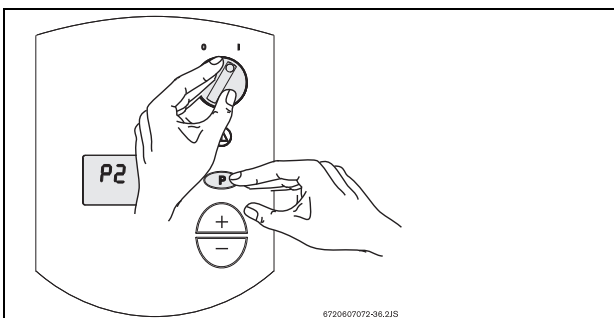

Fig. 6

B. Measuring CO₂ (Cover Installed):

- ▶ Open hot water taps to achieve a flow rate of at least 4 gallons per minute. (1 tub and 2 sinks should be sufficient).
- ▶ Record the CO₂ reading in P2 below. (Analyzer reading may take several minutes to stabilize).
- ▶ Press the '+' button until P1 appears. Unit will ramp up to high fire and the water flow should increase.
- ▶ Record the CO₂ reading in P1 below.

P2 CO₂ Reading: % CO₂

P1 CO₂ Reading: % CO₂

Compare your readings to those found in table 1 under the "With Front Cover" column. If CO₂ readings are off make adjustments as outlined below.

Note: The "Without Front Cover" column give approximate values with the cover off to ease the adjustment process. Final readings should be taken with the cover on.

C. Adjusting CO₂:

Note: P1 adjustment will change the P2 reading. Confirm the P1 value BEFORE adjusting the P2 level.

1. P1 CO₂ level adjustment:

- ▶ Loosen yellow painted Philips screw (1) and rotate cover down (2) revealing a brass slotted screw. Fig. 7.
- ▶ Adjusting the slotted screw counter clockwise will raise P1 CO₂ levels and clockwise will lower P1 CO₂ levels. Adjustments to the slotted screw will also change P2 CO₂ levels.

2. P2 CO₂ level adjustment:

- ▶ Remove yellow painted #40 Torx cover from the front of the gas valve. (Fig. 8) A plastic #40 Torx screw will be revealed.
- ▶ Adjusting the plastic #40 Torx screw counter clockwise will lower P2 CO₂ levels and clockwise will raise P2 CO₂ levels.

Note: This screw adjustment is very sensitive and may take several minutes to stabilize.

3. Verify both P1 and P2 are within the ranges specified in table 1 under the "With Front Cover" column. Repeat steps 1 and 2 as necessary until CO₂ values are within the specified ranges.

D. Returning to Service:

1. Return slotted cover to original position.
2. Reinstall Torx cover.
3. Remove CO₂ analyzer probe and reinstall flathead screw with gasket in exhaust collar.
4. Turn ON/OFF switch to the OFF (O) position and then back to the ON (I) position.
5. Heater is ready for normal operation.

		Without Front Cover	With Front Cover
		Nat. Gas	Nat. Gas
max. input	P1	9.1 ± 0.1 %	9.7 ± 0.1 %
min. input	P2	9.4 ± 0.1 %	9.7 ± 0.1 %
		LP Gas	LP Gas
max. input	P1	10.1 ± 0.1 %	10.7 ± 0.1 %
min. input	P2	10.4 ± 0.1 %	10.7 ± 0.1 %

* Final reading must be confirmed with the front cover on, CO₂ levels increase when the cover is installed.

Table 1

Final Readings

P2 CO₂ Reading: % CO₂

P1 CO₂ Reading: % CO₂

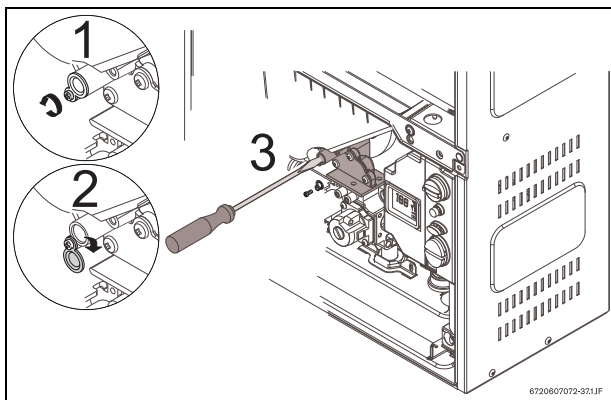

Fig. 7

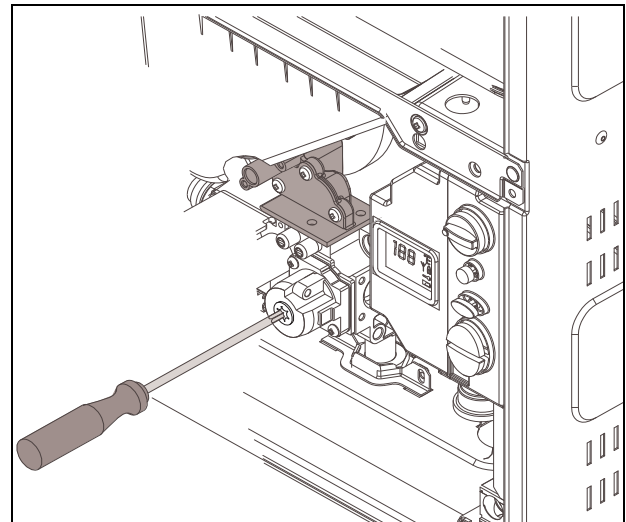



Fig. 8

3 Gas Type Conversion

For models: GWH 2400 ES, GWH 2700 ES, GWH 715 ES, Evolution 500, 830ES, 940ES, 940ESO only.

 **LP AND NG ARE EXTREMELY FLAMMABLE. TAKE EXTRA PRECAUTIONS WHEN PERFORMING ANY WORK TO THE HEATER.**

 **PROCEDURE MUST BE PERFORMED BY A LICENSED GAS TECHNICIAN.**

A. Preparation

- ▶ 1. Tools needed:
 - Flat and Phillips screwdrivers
 - #40 Torx driver
 - Digital combustion analyzer
- ▶ 2. Shut off gas supply at installer supplied shutoff valve and unplug the power cord.
- ▶ 3. Remove front cover.
- ▶ 4. Remove the three screws from the control unit.

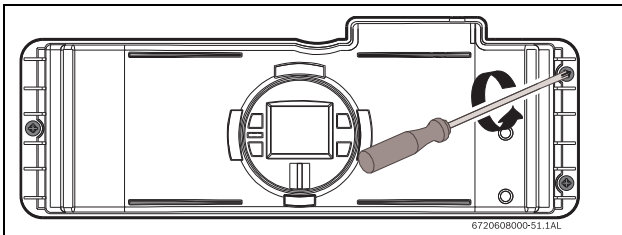

Fig. 9

- ▶ Pull control unit out and rotate to reveal the back side.
- ▶ Remove the small cover of the control unit.

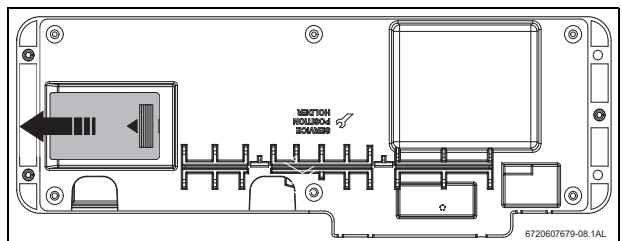

Fig. 10

B. Converting from LPG to NG

- ▶ 1. Add jumper to location JP6 on the control board (Fig. 11).

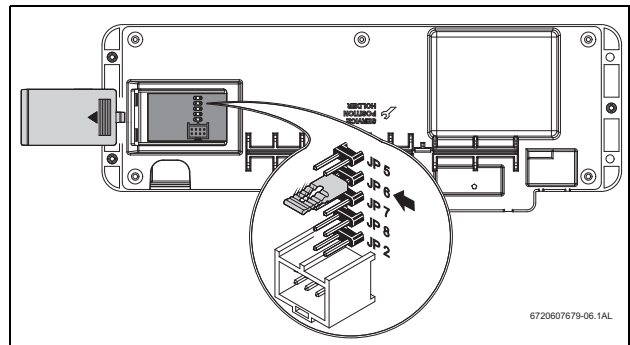



Fig. 11 LPG to NG

 P1 fan speed is automatically adjusted when is added the jumper, to verify value see Table 3.

- ▶ 2. Adjust CO₂ (see chapter 3.1).

C. Converting from NG to LPG

- ▶ 1. Remove jumper from location JP6 on the control board (Fig. 12).

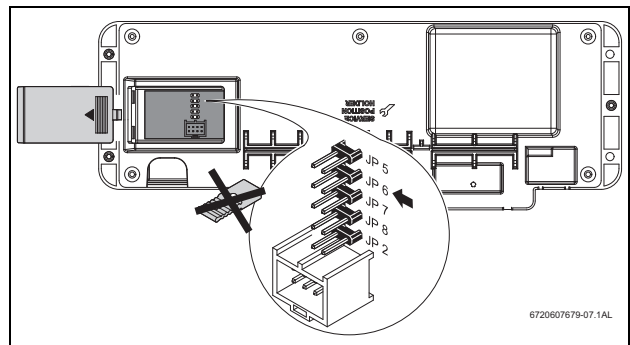



Fig. 12 NG to LPG

 P1 fan speed is automatically adjusted when jumper is removed, to verify value see Table 3.

- ▶ 2. Adjust CO₂ (see chapter 3.1).
- ▶ 3. Replace small cover on control unit's back and reinstall control unit in the water heater.

Operating Gas Pressure Test

- ▶ Press ON/OFF button to turn off the appliance.
- ▶ Press and hold "Program" (P) button and press ON/OFF button to turn appliance ON.

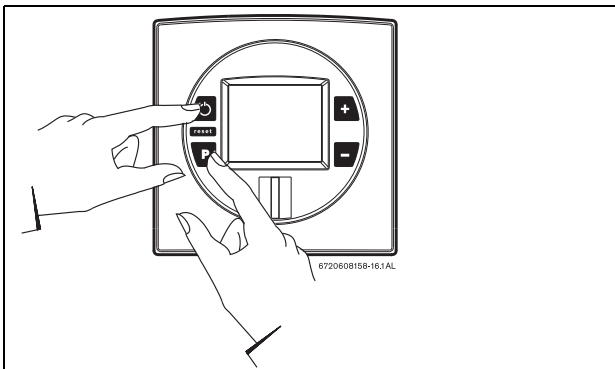

Fig. 13

- ▶ As soon as '188' is displayed, release "Program" **P** button and the display should read P2.
- ▶ Press **-** until P1 appears.

Note: While in this mode the appliance will run constantly at maximum power and allow maximum water flow.

For inlet gas pressure minimum specification, use the following table:

Gas type	NG	LPG
P1 pressure	3.5" WC	8" WC

Table 2 Minimum inlet gas pressure under full operation

- ▶ Turn on a high volume of hot water flow (at least 6 gpm) and heater will ignite. If heater display reverts to P2, open more hot water fixtures to allow sufficient flow. Press "**-**" until P1 reappears on display.
- ▶ Operate all other gas appliances on same gas piping system at maximum output.
- ▶ Record lowest operating gas pressure reading in table 4.

Gas pressures lower than 3.5" W.C. for Natural Gas or 8" W.C. for LPG will result in insufficient degree rise to the hot water, reduced hot water volume, possible error codes and must be corrected. See Gas Connections in the installation manual.

P1 fan speed (Factory default):

Model	NG	LPG
830ES	42	40
940ES	48	46
940ESO	48	46
GWH 715 ES	48	46
Evolution 500	48	46
GWH 2700 ES	48	46
GWH 2400 ES	42	40

Table 3 Fan speed values for P1 (factory default)

Lowering P1 fan speed reduces the maximum BTU input.

As a temporary measure if the gas pressure in P1 is below specification, lower P1 fan speed incrementally until minimum inlet gas pressure reaches specified range (Table 2). After raising gas pressure, reset appliance to P1 factory default setting.

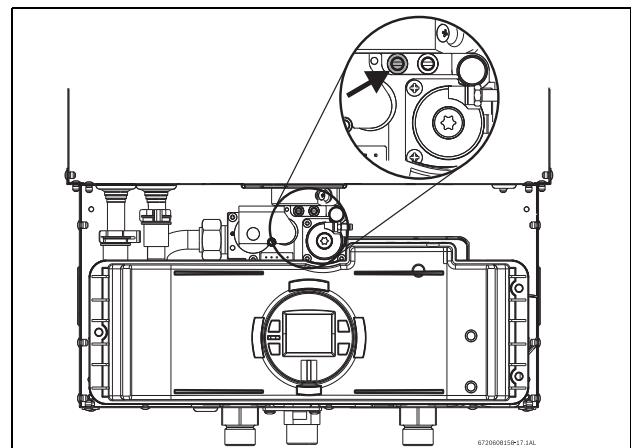

Fig. 14 Gas pressure test port (left tapping)

Static Gas Pressure Reading	
enter here: _____ " WC	Date: _____
Operating Gas Pressure Reading	
enter here: _____ " WC	Date: _____

Table 4

3.1 Adjusting CO₂

The CO₂ can only be adjusted by a certified gas technician with a calibrated CO₂ analyzer.



CO₂ adjustment is required in installations above 2,000ft. (610m), and in Natural Gas installations where energy content is less than 900 BTU/cu ft, and in installations with repeated unresolved EA and EC errors (ref. to "Problem solving" section of the installation manual.).

A. Once Gas Pressure is adequate

- ▶ Press ON/OFF button to turn off the heater.
- ▶ Remove brass flat head screw on the exhaust collar as seen in Fig. 5.
- ▶ Insert CO₂ analyzer probe into the measuring port. The tip of the probe should be in the center of the flue pipe (approx 1.5" inserted). Avoid air gaps between probe and measuring port as they can alter readings.

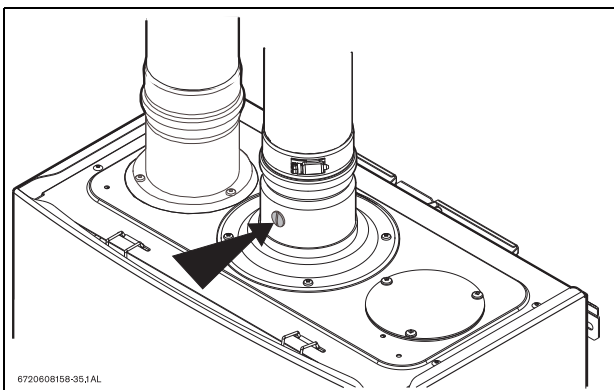

Fig. 15 Measuring port

- ▶ While holding the Program (P) button in, press the ON/OFF button to turn ON the heater (see Fig. 6). As soon as '188' flashes on the display, release the Program button. The display should now read P2. Press '−' button until "P1" appears on display.

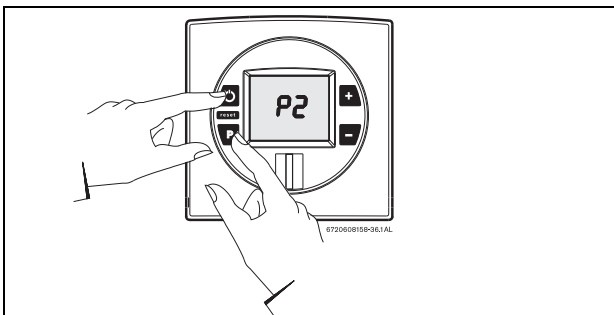

Fig. 16

B. Measuring CO₂ (combustion cover must be installed):

- ▶ Open all hot water taps to achieve a flow rate of at least 6 gallons per minute. (1 tub and 2 sinks should

be sufficient). If heater display reverts back to P2, open more hot water fixtures to allow sufficient flow.

- ▶ Press '−' until P1 reappears on display.
- ▶ Record the CO₂ reading in P1 below. (Analyzer reading may take several minutes to stabilize).
- ▶ Press the '+' button until P2 appears. Unit will ramp down to low fire and the flow should decrease.
- ▶ Record the CO₂ reading in P1 and P2 below.

P2 CO₂ Reading: % CO₂

P1 CO₂ Reading: % CO₂

Note: When making adjustments, make sure combustion cover is installed.

Values for GWH 715 ES, GWH 2700 ES, Evolution 500, 940ES, 940ESO			
		CO ₂ range (%)	Max. CO level (measured)
Nat. Gas			
max. input	P1	7.5 % - 8.1 %	< 250 ppm
min. input	P2	2.3 % - 2.6 %	< 60 ppm
LP Gas			
max. input	P1	8.7 % - 9.3 %	< 250 ppm
min. input	P2	2.7 % - 3.0 %	< 60 ppm
* Values above are for climate controlled conditions. Inputs such as gas pressure, heating value of the gas, humidity and temperature of combustion air all impact CO and CO ₂ values. Changes in these inputs can result in different CO and CO ₂ values on the same appliance.			

Table 5 CO₂ & CO target numbers

Values for GWH 2400 ES, 830ES			
		CO ₂ range (%)	Max. CO level (measured)
Nat. Gas			
max. input	P1	7.2 % - 7.8 %	< 250 ppm
min. input	P2	2.3 % - 2.6 %	< 60 ppm
LP Gas			
max. input	P1	8.3 % - 8.9 %	< 250 ppm
min. input	P2	2.6 % - 2.9 %	< 60 ppm

* Values above are for climate controlled conditions. Inputs such as gas pressure, heating value of the gas, humidity and temperature of combustion air all impact CO and CO₂ values. Changes in these inputs can result in different CO and CO₂ values on the same appliance.

Table 6 CO₂ & CO target numbers

C. Adjusting CO₂:

Note: P1 adjustment will change the P2 reading. Confirm the P1 value BEFORE adjusting the P2 level.

1. If P1 CO₂ level is off:

- ▶ Loosen yellow painted philips screw (1) and cover should rotate down (2) revealing a recessed brass slotted screw. Fig. 17.
- ▶ Turning the slotted screw counter clockwise will raise P1 CO₂ levels and clockwise will lower P1 CO₂ levels. Adjustments to the slotted screw will also change P2 CO₂ levels.
- ▶ After the P1 CO₂ readings are correct, press the '+' button to enter the P2 mode. Verify CO₂ readings in P2 mode.

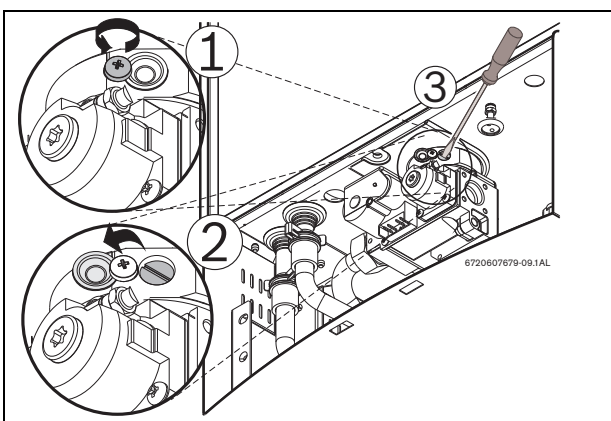

Fig. 17 Adjusting P1 CO₂ level

2. If P2 CO₂ level is off:

- ▶ Remove yellow painted #40 Torx cover from the front of the gas valve. (Fig. 18, pos.1) A plastic #40 Torx screw will be revealed.
- ▶ Turning the plastic #40 Torx screw counter clockwise will lower P2 CO₂ levels and clockwise will raise P2 CO₂ levels. (Fig. 18, pos. 2).

Note: This screw adjustment is very sensitive and should be made in small increments. It may take several minutes for readings to stabilize.

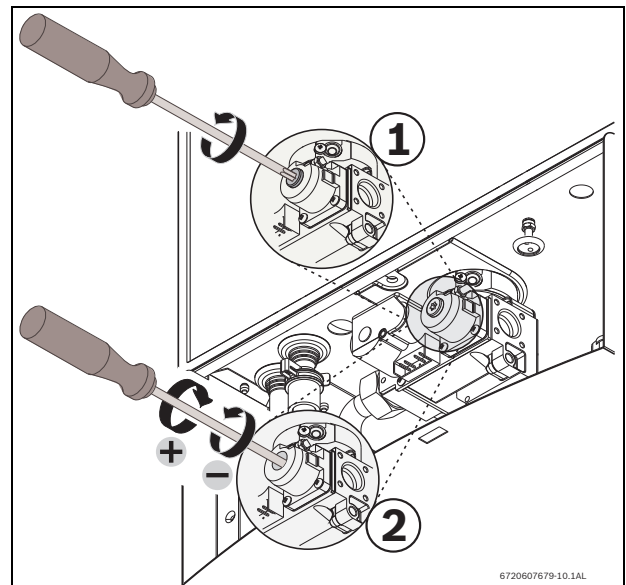

Fig. 18 Adjusting P2 CO₂ level

Final Readings

P2 CO₂ Reading: % CO₂

P1 CO₂ Reading: % CO₂

3. Verify both P1 and P2 CO₂ readings are within the ranges specified in table 5 or 6. Repeat steps 1 and 2 as necessary until CO₂ values are within the specified ranges.

4. Once CO₂ values are within the specified ranges, measure the CO readings on P1 and P2. These readings can't exceed the values shown in table 5 or 6 according to your appliance. If values exceed this limit, inspect vent system and heat exchanger fin coils for blockage.

D. Returning to Service:

1. Return slotted screw cover to original position and tighten philips screw.
2. Reinstall Torx cover.
3. Remove CO₂ analyzer probe and reinstall flathead screw with gasket in exhaust collar.
4. Apply conversion sticker to the right side of front cover above rating plate sticker. Ensure information is filled out accurately.
5. Press ON/OFF button to turn OFF the heater and then turn ON the heater.
6. Heater is ready for normal operation.



6720607679

Replacement Parts available from:

**BOSCH THERMOTECHNOLOGY
CORP.**

50 Wentworth Avenue
Londonderry, NH 03053
Tel. 866-330-2730
www.bosch-climate.us

Bosch Termotecnologia SA
Estrada de Cacia
3800 - 533 Cacia - PORTUGAL