



BOSCH



ProtoAir FPA-W44 Start-up Guide

For Interfacing Bosch Products:
C_Platform, D_Platform

To Building Automation Systems:
BACnet MS/TP, BACnet/IP, Modbus TCP/IP, Metasys N2 and SMC Cloud

APPLICABILITY & EFFECTIVITY

Explains ProtoAir hardware and how to install it.
The instructions are effective for the above as of March 2020.

Technical Support

Thank you for purchasing the ProtoAir for Bosch.

Please call Bosch for technical support of the ProtoAir product.

MSA Safety does not provide direct support. If Bosch needs to escalate the concern, they will contact MSA Safety for assistance.

Support Contact Information:

Robert Bosch LLC
38000 Hills Tech Drive
Farmington Hills
Michigan 48331 USA

Customer Service:
(917) 421-7209

Contact via website: www.bosch.us/contact

Website: www.bosch.us

Quick Start Guide

1. Methods of Configuration: (**Section 2.2**)
 - Auto-Discovery: See **Figure 1** for the table of devices that support automatic configuration.
 - Web Configurator: For devices that cannot be automatically configured, use a web browser to access the Web Configurator page.
2. Record the information about the unit. (**Section 3.1**)
3. Check that the ProtoAir and customer device COM settings match. (**Section 3.3**)
4. Connect the ProtoAir 3 pin RS-485/RS-232 R1 port to the RS-485 or RS-232 network connected to each of the devices. (**Section 4.1**)
5. **If using a serial field protocol:**
Connect the ProtoAir 3 pin RS-485 R2 port to the field protocol cabling. (**Section 4.2**)
6. Connect power to ProtoAir 3 pin power port. (**Section 4.5**)
7. Connect a PC to the ProtoAir via Ethernet cable. (**Section 5**)
8. Auto-Discovery Devices: On the Web Configurator page, click the Discovery Mode button at the bottom of the screen. It may take about 3 minutes for all the devices to be discovered and the configuration file to be built. (**Section 6.3.1**)
9. Web Configuration Devices: Use a web browser to access the ProtoAir Web Configurator page to select the profile of the device attached to the ProtoAir and enter any necessary device information. Once the device is selected, the ProtoAir automatically builds and loads the appropriate configuration. (**Section 6.3.2**)

TABLE OF CONTENTS

- 1 Certification 7**
 - 1.1 BTL Mark – BACnet® Testing Laboratory 7
- 2 Introduction 8**
 - 2.1 ProtoAir Gateway 8
 - 2.2 Methods of Configuration 9
- 3 ProtoAir Setup 10**
 - 3.1 Record Identification Data 10
 - 3.2 Point Count Capacity 10
 - 3.3 Configuring Device Communications 11
 - 3.3.1 Confirm the Device and ProtoAir COM Settings Match 11
 - 3.3.2 Set the Station Address for Any Device Attached to the ProtoAir 11
 - 3.4 Attaching the Antenna 11
- 4 Interfacing ProtoAir to Devices 12**
 - 4.1 Device Connections to ProtoAir 12
 - 4.1.1 Wiring for C_Platform Cascade SSB 255, 399 & 512 13
 - 4.1.2 Wiring for D_Platform Cascade SSB 800 & 1000 14
 - 4.2 Wiring Field Port to RS-485 Serial Network 15
 - 4.3 Bias Resistors 16
 - 4.4 Termination Resistor 17
 - 4.5 Power-Up ProtoAir 18
- 5 Connect the PC to the ProtoAir 19**
 - 5.1 Connecting to the ProtoAir via Ethernet 19
 - 5.1.1 Changing the Subnet of the Connected PC 19
- 6 Configure the ProtoAir 20**
 - 6.1 Accessing the ProtoAir Web Configurator 20
 - 6.2 Select Field Protocol and Set Configuration Parameters 22
 - 6.3 Configure Devices Connected to the Gateway 23
 - 6.3.1 Use Discovery Mode 23
 - 6.3.2 Set ProtoAir Active Profiles 24
 - 6.4 Verify Device Communications 25
 - 6.5 BACnet: Setting Node_Offset to Assign Specific Device Instances 26
 - 6.6 How to Start the Installation Over: Clearing Profiles 27
- 7 Network Settings 28**
 - 7.1 Navigate to the FS-GUI Network Settings 28
 - 7.2 Change the ProtoAir IP Address 30
 - 7.2.1 Update Wired Network Settings 31
 - 7.2.2 Update Wi-Fi Client Settings 32
 - 7.2.3 Common Settings 33
- 8 SMC Cloud User Setup, Registration and Login 34**
 - 8.1 User Setup 34
 - 8.2 Registration Process 36
 - 8.3 Login to SMC Cloud 40
- Appendix A Troubleshooting 42**
 - Appendix A.1 Lost or Incorrect IP Address 42
 - Appendix A.2 Viewing Diagnostic Information 43
 - Appendix A.3 Checking Wiring and Settings 44
 - Appendix A.4 LED Diagnostics for Communications Between ProtoAir and Devices 45
 - Appendix A.5 Taking a FieldServer Diagnostic Capture 46
 - Appendix A.5.1 Using the FieldServer Toolbox 46
 - Appendix A.5.2 Using FS-GUI 49
 - Appendix A.6 Wi-Fi Signal Strength 50
 - Appendix A.7 Factory Reset Instructions 50
 - Appendix A.8 Internet Browsers Not Supported 50

Appendix B Additional Information.....	51
Appendix B.1 Updating Firmware.....	51
Appendix B.2 BACnet: Setting Network_Number for More Than One ProtoAir on the Subnet	51
Appendix B.3 Securing ProtoAir with Passwords.....	52
Appendix B.4 Wi-Fi Access Point Network Settings	53
Appendix B.5 Mounting	54
Appendix B.6 Physical Dimension Drawing	55
Appendix C Vendor Information – Bosch.....	56
Appendix C.1 C_Platform Modbus RTU Mappings to BACnet, Modbus TCP/IP and Metasys N2.....	56
Appendix C.2 D_Platform Modbus RTU Mappings to BACnet, Modbus TCP/IP and Metasys N2.....	58
Appendix D Reference.....	63
Appendix D.1 Specifications.....	63
Appendix D.1.1 Compliance with UL Regulations	63
Appendix E Limited 2 Year Warranty	64

LIST OF FIGURES

Figure 1: Method of Configuration for the Devices 9

Figure 2: ProtoAir Part Numbers..... 10

Figure 3: Supported Point Count Capacity 10

Figure 4: Points per Device 10

Figure 5: COM Settings..... 11

Figure 6: RS-485 and RS-232 Connections from Devices to the ProtoAir 12

Figure 7: R1 Port RS-485/RS-232 DIP Switch..... 12

Figure 8: ProtoAir Wiring for C_Platform Device 13

Figure 9: ProtoAir Wiring for D_Platform Device 14

Figure 10: Connection from ProtoAir to RS-485 Field Network 15

Figure 11: Bias Resistor DIP Switches 16

Figure 12: Termination Resistor DIP Switch 17

Figure 13: Required Current Draw for the ProtoAir..... 18

Figure 14: Power Connections..... 18

Figure 15: Ethernet Port Location 19

Figure 16: Web App Splash Page..... 20

Figure 17: Login Window 20

Figure 18: Web App Landing Page..... 21

Figure 19: Configure Tab 21

Figure 20: Web Configurator Showing Protocol Selector Parameter 22

Figure 21: Web Configurator Showing Discovery Mode Button 23

Figure 22: Web Configurator Showing Discovered Profiles..... 23

Figure 23: Web Configurator Showing no Active Profiles 24

Figure 24: Profile Selection Menu..... 25

Figure 25: Web Configurator Showing Active Profile Additions..... 25

Figure 26: Web Configurator Node Offset Field..... 26

Figure 27: Active Profiles 26

Figure 28: Web App Landing Page..... 28

Figure 29: Web Configurator Page – Diagnostics Button 28

Figure 30: FS-GUI Landing Page 29

Figure 31: Generic FS-GUI Navigation Panel – Network Settings 29

Figure 32: FS-GUI Ethernet Port Network Settings 31

Figure 33: FS-GUI Wi-Fi Client Network Settings..... 32

Figure 34: FS-GUI Common Network Settings..... 33

Figure 35: Welcome to SMC Cloud Email 34

Figure 36: Setting User Details 35

Figure 37: Web App Landing Page – SMC Cloud Tab 36

Figure 38: Registration Information Page 36

Figure 39: SMC Cloud Connection Problems Message 37

Figure 40: SMC Cloud Registration Page..... 38

Figure 41: Device Registered for SMC Cloud..... 39

Figure 42: SMC Cloud Login Page 40

Figure 43: SMC Cloud Privacy Policy 40

Figure 44: SMC Cloud Landing Page 41

Figure 45: Ethernet Port Location 42

Figure 46: Error Messages Screen 43

Figure 47: Diagnostic LEDs 45

Figure 48: Ethernet Port Location 46

Figure 49: Wi-Fi Signal Strength Listing 50

Figure 50: Web Configurator – Network Number Field..... 51

Figure 51: FS-GUI Passwords Page..... 52

Figure 52: Password Recovery Page 52

Figure 53: FS-GUI Wi-Fi AP Network Settings 53

Figure 54: DIN Rail..... 54

Figure 55: ProtoAir FPA-W44 Dimensions 55

Figure 56: Specifications..... 63

1 CERTIFICATION

1.1 BTL Mark – BACnet^{®1} Testing Laboratory



BTL is a registered trademark of ASHRAE. ASHRAE does not endorse, approve or test products for compliance with ASHRAE standards. Compliance of listed products to requirements of ASHRAE Standard 133 is the responsibility of the BACnet International. BTL is a registered trademark of the BACnet International.

The BTL Mark on ProtoAir is a symbol that indicates that a product has passed a series of rigorous tests conducted by an independent laboratory which verifies that the product correctly implements the BACnet features claimed in the listing. The mark is a symbol of a high-quality BACnet product.

Go to www.BACnetInternational.net for more information about the BACnet Testing Laboratory. Click [here](#) for the BACnet PIC Statement.

¹ BACnet is a registered trademark of ASHRAE

2 INTRODUCTION

2.1 ProtoAir Gateway

The ProtoAir wireless gateway is an external, high performance **building automation multi-protocol gateway** that is preconfigured to automatically communicate between Bosch’s devices (hereafter simply called “device”) connected to the ProtoAir and automatically configures them for BACnet/IP, BACnet MS/TP, Modbus TCP/IP and Metasys^{®2} N2.

It is not necessary to download any configuration files to support the required applications. The ProtoAir is pre-loaded with tested profiles/configurations for the supported devices.

FPA-W44 Connectivity Diagram:

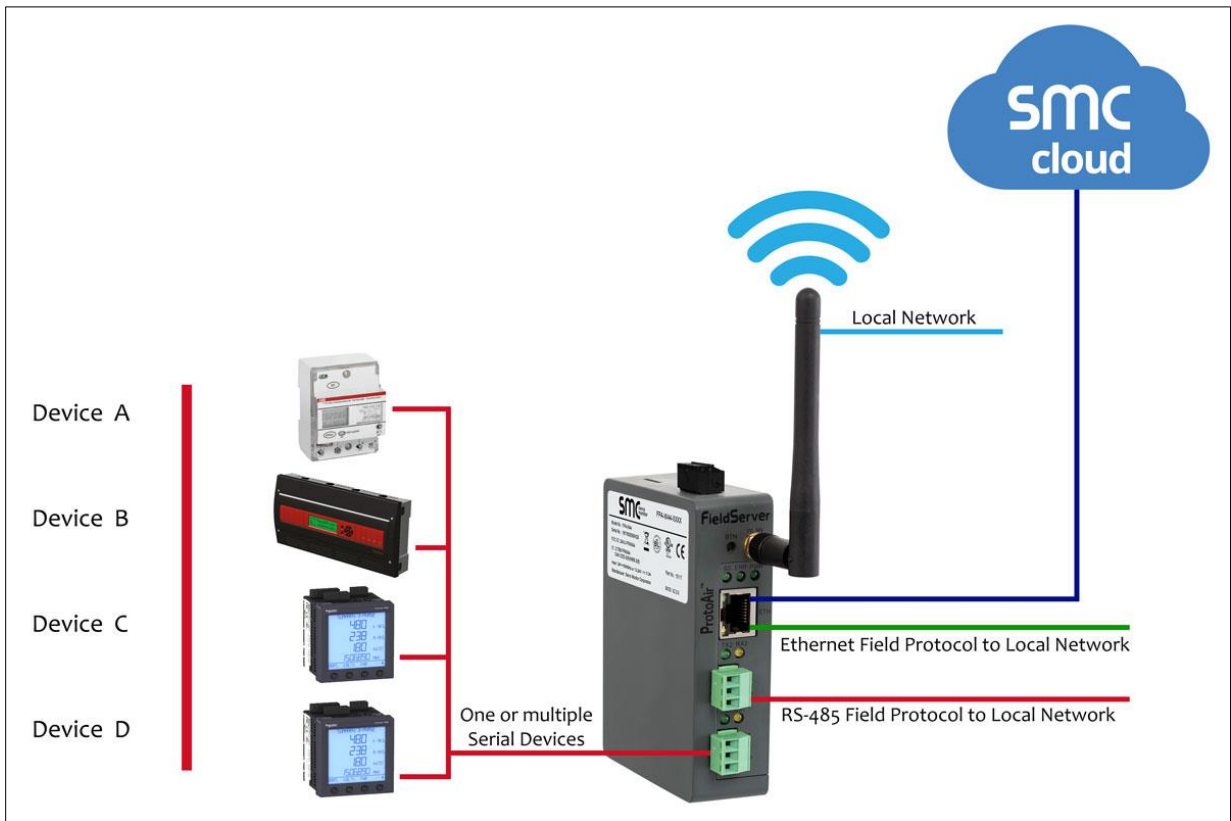

The ProtoAir can connect with the SMC Cloud. The SMC Cloud allows technicians, the OEM's support team and MSA Safety's support team to remotely connect to the ProtoAir. The SMC Cloud provides the following capabilities for any registered devices in the field:

- Remotely monitor and control devices.
- Collect device data and view it on the SMC Cloud Dashboard and the SMC Smart Phone App.
- Create user defined device notifications (alarm, trouble and warning) via SMS and/or Email.
- Generate diagnostic captures (as needed for troubleshooting) without going to the site.

For more information about the SMC Cloud, refer to the [SMC Cloud Start-up Guide](#).

² Metasys is a registered trademark of Johnson Controls Inc.

2.2 Methods of Configuration

The ProtoAir offers two methods of configuration:

- **Auto-Discovery:** Supported RS-485 devices can be automatically detected and identified for addition to the ProtoAir's configuration via the ProtoAir's Web Configurator. (**Section 6.3.1**)
- **Web Configurator:** Devices that cannot be identified by Auto-Discovery must be configured to the gateway by selecting profiles on the ProtoAir's Web Configurator. The Web Configurator shows all the stored profiles/devices on the ProtoAir. It will also show all the devices that were previously discovered or selected. To configure, select a device and enter the Station Address. Once all required device profiles are saved, the ProtoAir automatically builds and downloads the configuration for the desired protocol. (**Section 6.3.2**)

Devices	Communication	Connection Type	Type of Configuration
C_Platform	Modbus RTU	RS-485	Auto-Discovery
D_Platform (1 - 8 boilers)	Modbus RTU	RS-485/RS-232	Web-Configurator

Figure 1: Method of Configuration for the Devices

3 PROTOAIR SETUP

3.1 Record Identification Data

Each ProtoAir has a unique part number located on the side or the back of the unit. This number should be recorded, as it may be required for technical support. The numbers are as follows:

Model	Part Number
ProtoAir	FPA-W44-1726
Figure 2: ProtoAir Part Numbers	

- FPA-W44 units have the following 4 ports: Ethernet + Wi-Fi + RS-485 + RS-485/RS-232

3.2 Point Count Capacity

The total number of points presented the device(s) attached to the ProtoAir cannot exceed:

Part number	Total Points
FPA-W44-1726	1,500
Figure 3: Supported Point Count Capacity	

Devices	Points Per Device
C_Platform	154
D_Platform (1 - 8 boilers) ³	30 - 54 - 78 - 102 - 126 - 150 - 174 - 198
Figure 4: Points per Device	

³ The numbers in the D_Platform Points column are for 1 boiler, 2 boilers, 3 boilers, etc.

3.3 Configuring Device Communications

3.3.1 Confirm the Device and ProtoAir COM Settings Match

- Any connected serial device **MUST** have the same baud rate, data bits, stop bits, and parity settings as the ProtoAir.
- **Figure 5** specifies the device serial port settings required to communicate with the ProtoAir.

Port Setting	Device
Protocol	Modbus RTU
Baud Rate	9600
Parity	None
Data Bits	8
Stop Bits	2

Figure 5: COM Settings

3.3.2 Set the Station Address for Any Device Attached to the ProtoAir

- Set the Station Address for the device attached to ProtoAir. The Station Address needs to be uniquely assigned between 1 and 255.
- Document the Station Address that is assigned. The Station Address assigned is used for deriving the Device Instance for BACnet/IP and BACnet MS/TP. (**Section 6.5**)

NOTE: The Metasys N2 and Modbus TCP/IP field protocol Station Addresses are automatically set to be the same value as the Station Address of the device.

3.4 Attaching the Antenna

Wi-Fi Antenna:

Screw in the Wi-Fi antenna to the front of the unit as shown in **Figure 55**.

NOTE: Using an external antenna is also an option. An external antenna can be plugged into the SMA connector. The best antenna for the job depends on the range, topography and obstacles between the two radios.

4 INTERFACING PROTOAIR TO DEVICES

4.1 Device Connections to ProtoAir

The ProtoAir has a 3-pin Phoenix connector for connecting RS-485 or RS-232 devices on the R1 port.

NOTE: Use standard grounding principles for RS-485 or RS-232 GND.

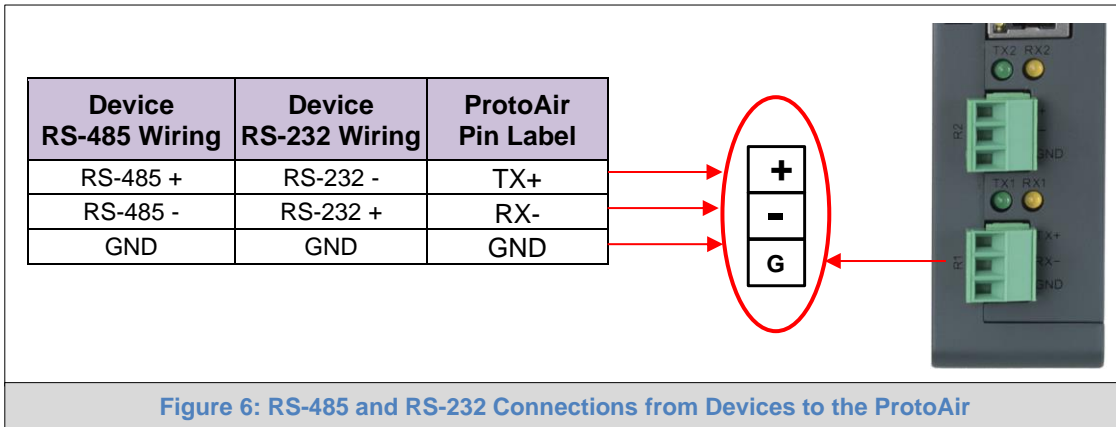

To switch the R1 port between RS-485 and RS-232, move the number 4 DIP Switch left for RS-485 and right for RS-232.

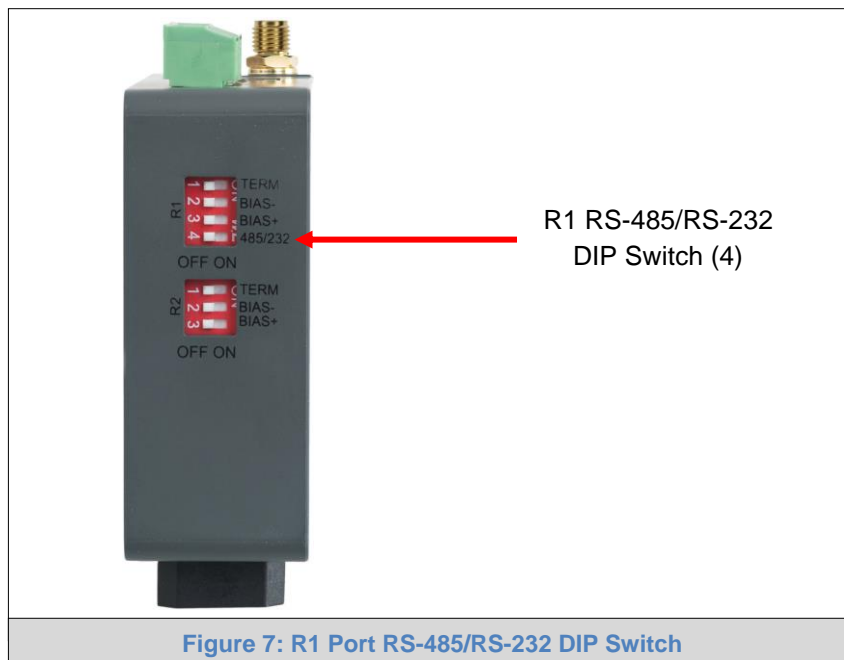

4.1.1 Wiring for C_Platform Cascade SSB 255, 399 & 512

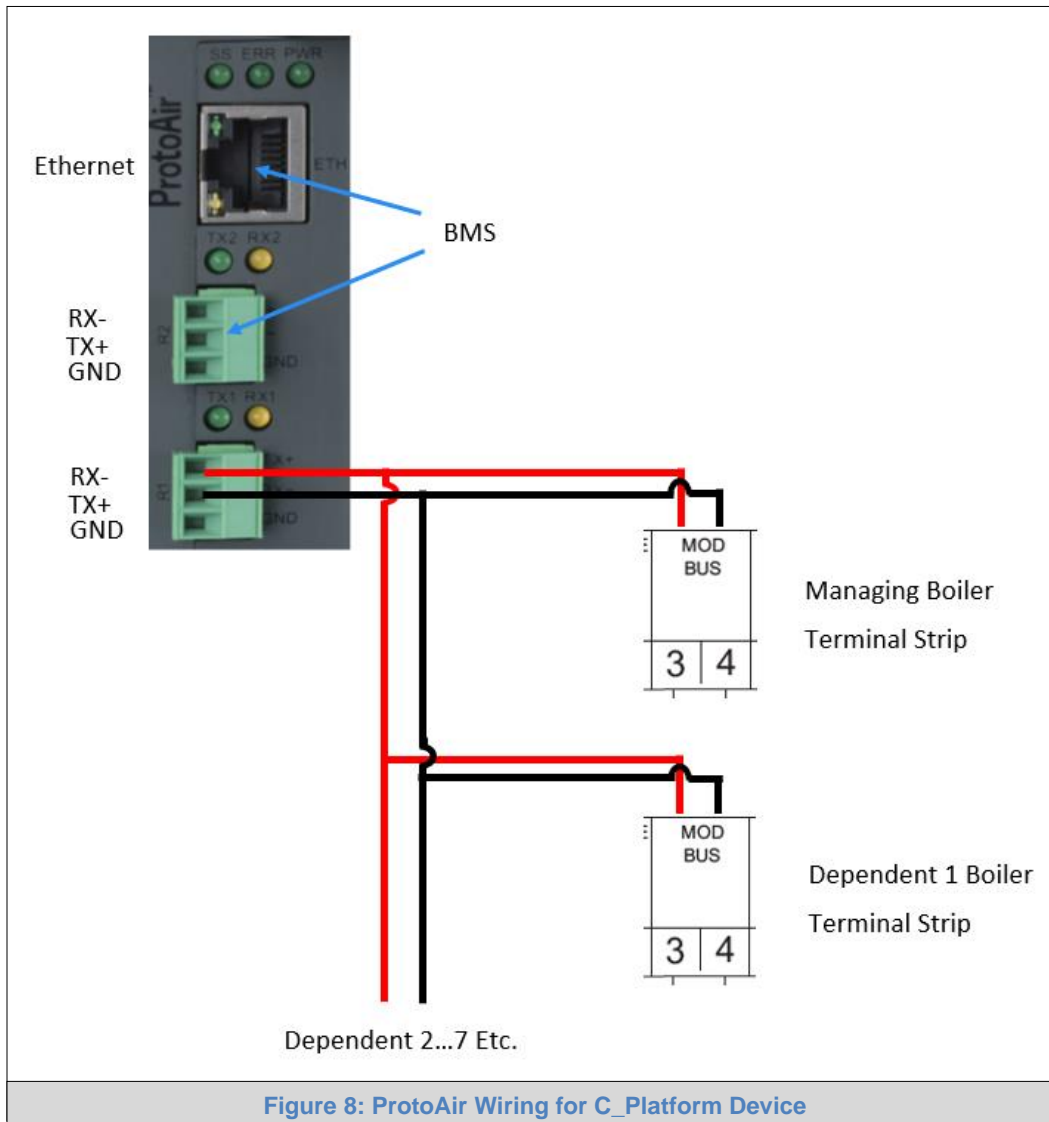

Figure 8: ProtoAir Wiring for C_Platform Device

In the ProtoAir Web Configurator, set Node-ID to 1 for Managing, 2 for Dependent 1, 3 for Dependent 2, etc. Change the Modbus Address for each Boiler Control to match the Node-ID.

Example (Bacnet/IP 3 Boiler Cascade):

Active profiles			
Nr	Node ID	Current profile	Parameters
1	1	BAC_IP_C_Platform	
2	2	BAC_IP_C_Platform	
3	3	BAC_IP_C_Platform	

Add

NOTE: To manually configure a profile that can be auto-discovered, just follow the Active Profile setup instruction in Section 6.3.2.

4.1.2 Wiring for D_Platform Cascade SSB 800 & 1000

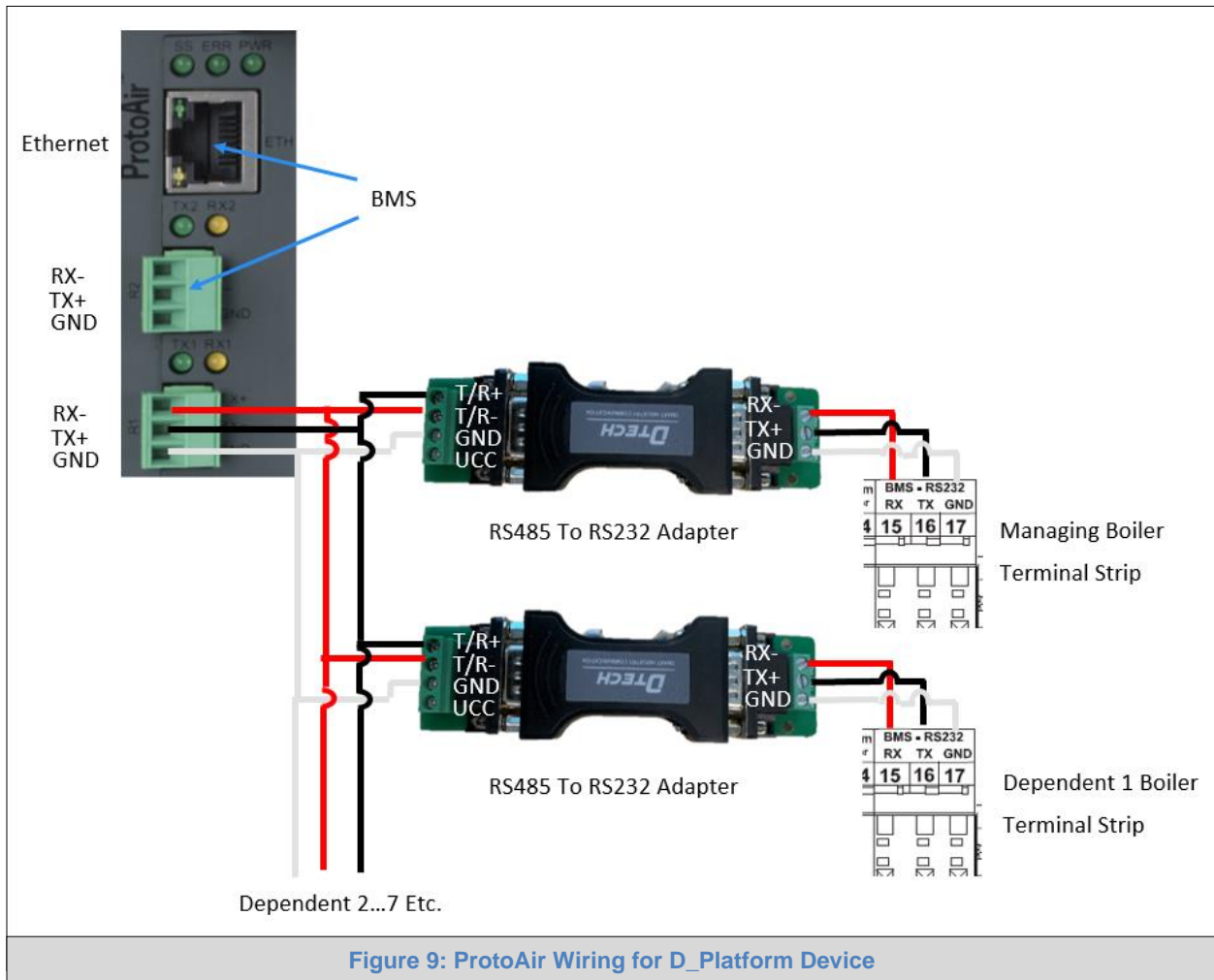

Figure 9: ProtoAir Wiring for D_Platform Device

In the ProtoAir Web Configurator, the Node-ID should always be set to 1. Do not change the Modbus Address in Boiler Control. See **Section 6.3.2**.

Example (Bacnet/IP 3 Boiler Cascade):

Active profiles		
Nr	Node ID	Current profile
1	1	BAC_IP_D_Plac_3_Blrs

Add

4.2 Wiring Field Port to RS-485 Serial Network

- Connect the RS-485 network wires to the 3-pin RS-485 connector on the R2 port. (Figure 10)
 - Use standard grounding principles for RS-485 GND
- See **Section 5** for information on connecting to an Ethernet network.

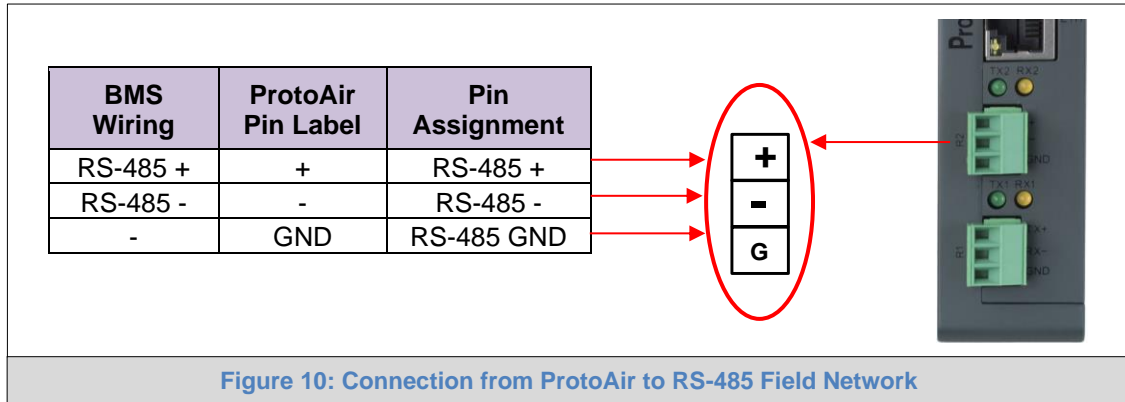

4.3 Bias Resistors

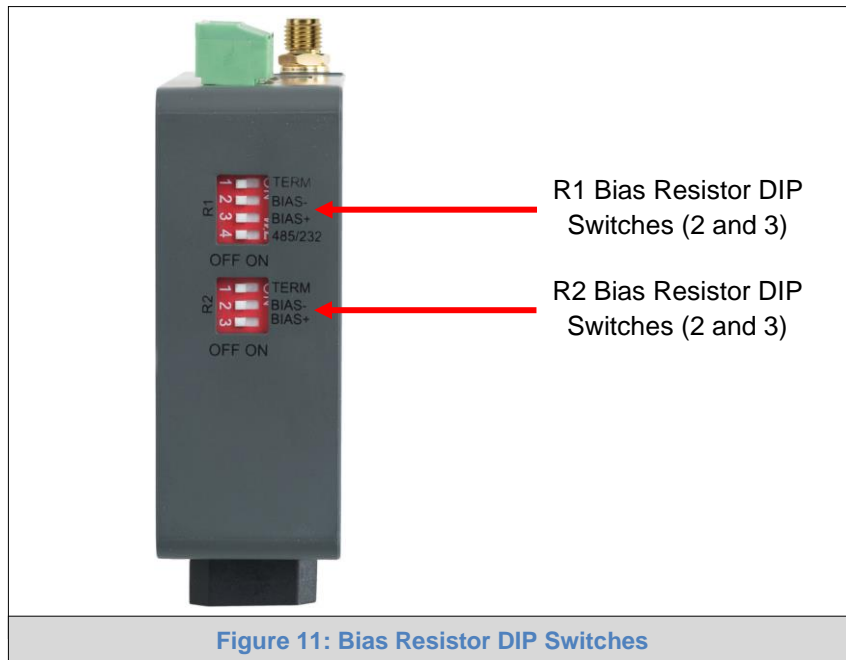

Figure 11: Bias Resistor DIP Switches

To enable Bias Resistors, move both the BIAS- and BIAS+ dip switches to the right as shown in Figure 11.

The ProtoAir bias resistors are used to keep the RS-485 bus to a known state, when there is no transmission on the line (bus is idling), to help prevent false bits of data from being detected. The bias resistors typically pull one line high and the other low - far away from the decision point of the logic.

The bias resistor is 510 ohms which is in line with the BACnet spec. It should only be enabled at one point on the bus (for example, on the field port where there are very weak bias resistors of 100k). Since there are no jumpers, many gateways can be put on the network without running into the bias resistor limit which is < 500 ohms.

NOTE: See www.ni.com/support/serial/resinfo.htm for additional pictures and notes.

NOTE: The R1 and R2 DIP Switches apply settings to the respective serial port.

NOTE: If the gateway is already powered on, DIP switch settings will not take effect unless the unit is power cycled.

4.4 Termination Resistor

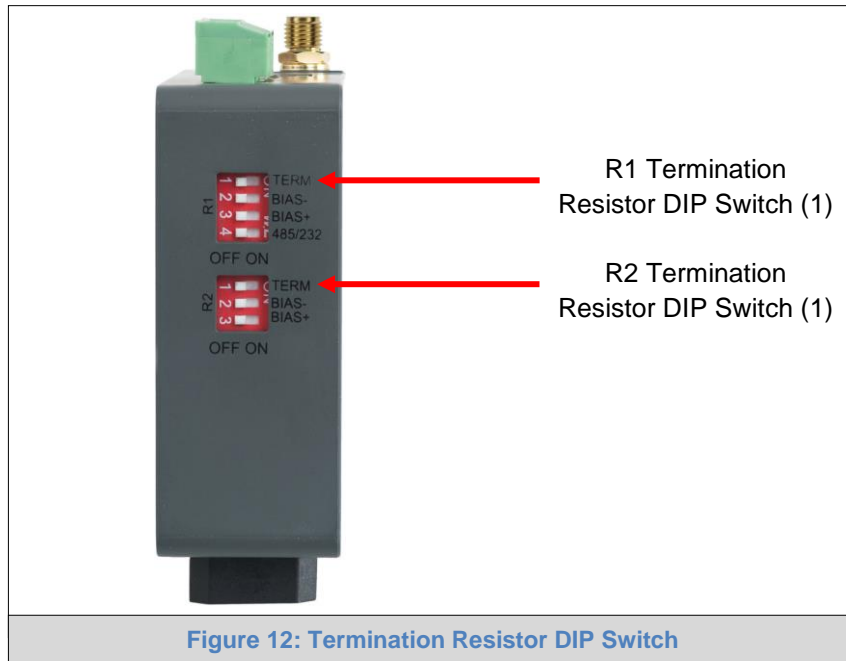

Figure 12: Termination Resistor DIP Switch

If the ProtoAir is the last device on the serial trunk, then the End-Of-Line Termination Switch needs to be enabled. **To enable the Termination Resistor, move the TERM dip switch to the right as shown in Figure 12.**

Termination resistor is also used to reduce noise. It pulls the two lines of an idle bus together. However, the resistor would override the effect of any bias resistors if connected.

NOTE: The R1 and R2 DIP Switches apply settings to the respective serial port.

NOTE: If the gateway is already powered on, DIP switch settings will not take effect unless the unit is power cycled.

4.5 Power-Up ProtoAir

Check power requirements in the table below:

Power Requirement for ProtoAir External Gateway		
	Current Draw Type	
ProtoAir Family	12VDC	24VDC/AC
FPA – W44 (Typical)	250mA	125mA
NOTE: These values are 'nominal' and a safety margin should be added to the power supply of the host system. A safety margin of 25% is recommended.		
Figure 13: Required Current Draw for the ProtoAir		

Apply power to the ProtoAir as shown below in [Figure 14](#). Ensure that the power supply used complies with the specifications provided in [Appendix D.1](#).

- The ProtoAir accepts 9-30VDC or 24VAC on pins L+ and N-.
- Frame GND should be connected.

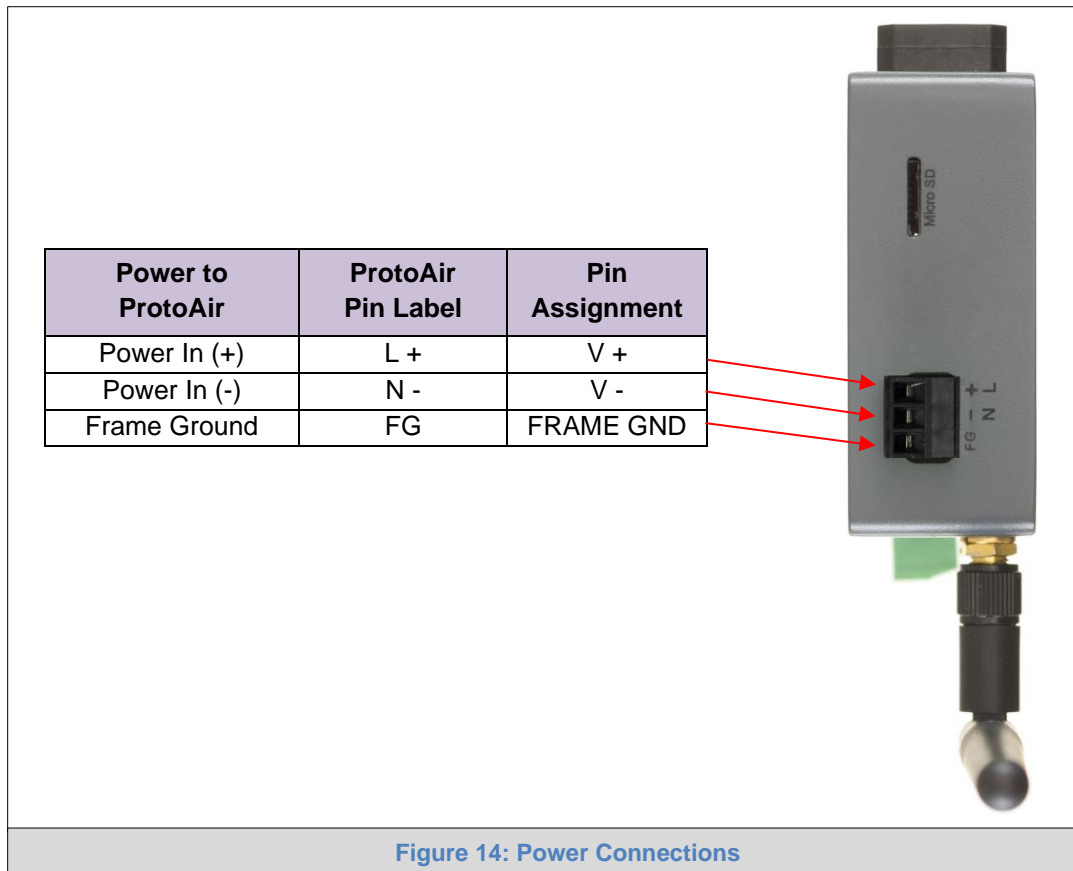

5 CONNECT THE PC TO THE PROTOAIR

5.1 Connecting to the ProtoAir via Ethernet

Connect a Cat-5 Ethernet cable (straight through or cross-over) between the local PC and ProtoAir.

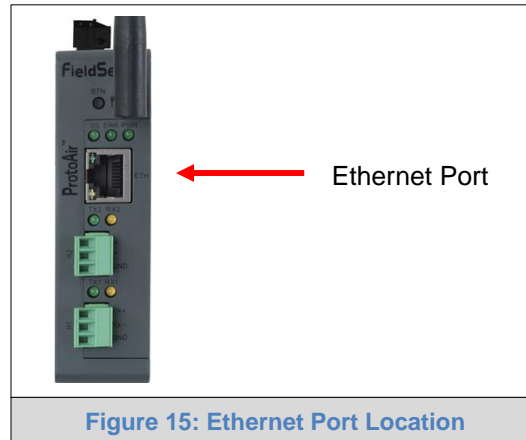

5.1.1 Changing the Subnet of the Connected PC

The default IP Address for the ProtoAir is **192.168.1.24**, Subnet Mask is **255.255.255.0**. If the PC and ProtoAir are on different IP networks, assign a static IP Address to the PC on the 192.168.1.xxx network.

For Windows 10:

- Find the search field in the local computer's taskbar (usually to the right of the windows icon ) and type in "Control Panel".
- Click "Control Panel", click "Network and Internet" and then click "Network and Sharing Center".
- Click "Change adapter settings" on the left side of the window.
- Right-click on "Local Area Connection" and select "Properties" from the dropdown menu.
- Highlight [Internet Protocol Version 4 \(TCP/IPv4\)](#) and then click the Properties button.
- Select and enter a static IP Address on the same subnet. For example:

Use the following IP address:

IP address:	<input type="text" value="192 . 168 . 1 . 11"/>
Subnet mask:	<input type="text" value="255 . 255 . 255 . 0"/>
Default gateway:	<input type="text" value=" . . ."/>

- Click the Okay button to close the Internet Protocol window and the Close button to close the Ethernet Properties window.

6 CONFIGURE THE PROTOAIR

6.1 Accessing the ProtoAir Web Configurator

- Navigate to the IP Address of the ProtoAir on the local PC by opening a web browser and entering the IP Address of the ProtoAir; the default Ethernet address is 192.168.1.24.

NOTE: If the IP Address of the ProtoAir has been changed, the IP Address can be discovered using the FS Toolbox utility. See Appendix A.1 for instructions.

- Once at the Web App splash page, click the Login button.

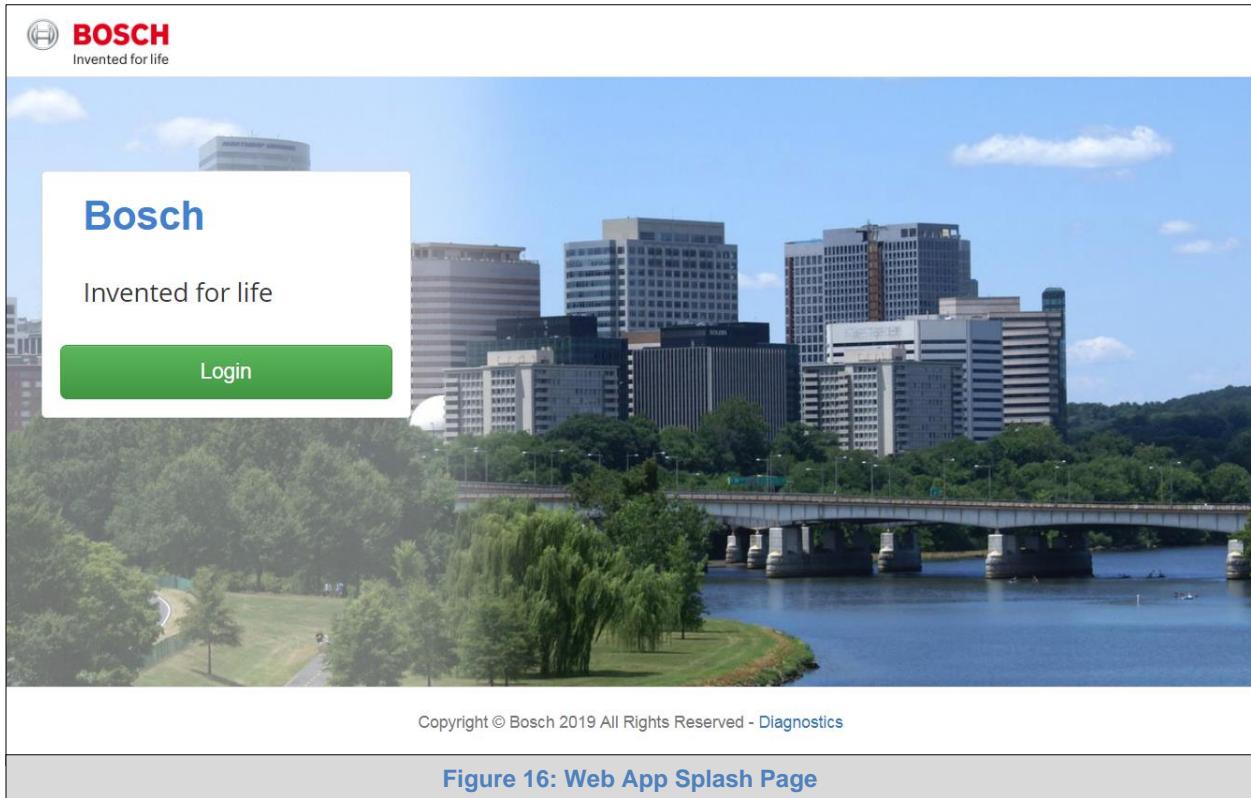

Figure 16: Web App Splash Page

- Enter the previously set up or default username and password.

NOTE: The default username is “admin”. The default password is “admin”.

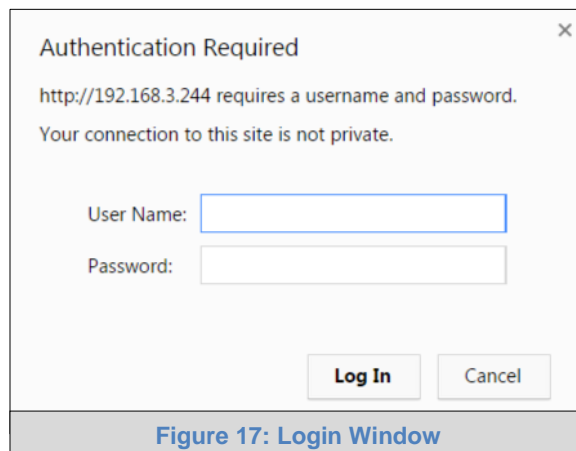

Figure 17: Login Window

- From the Web App landing page ([Figure 18](#)), click the Settings tab and then click Configuration.

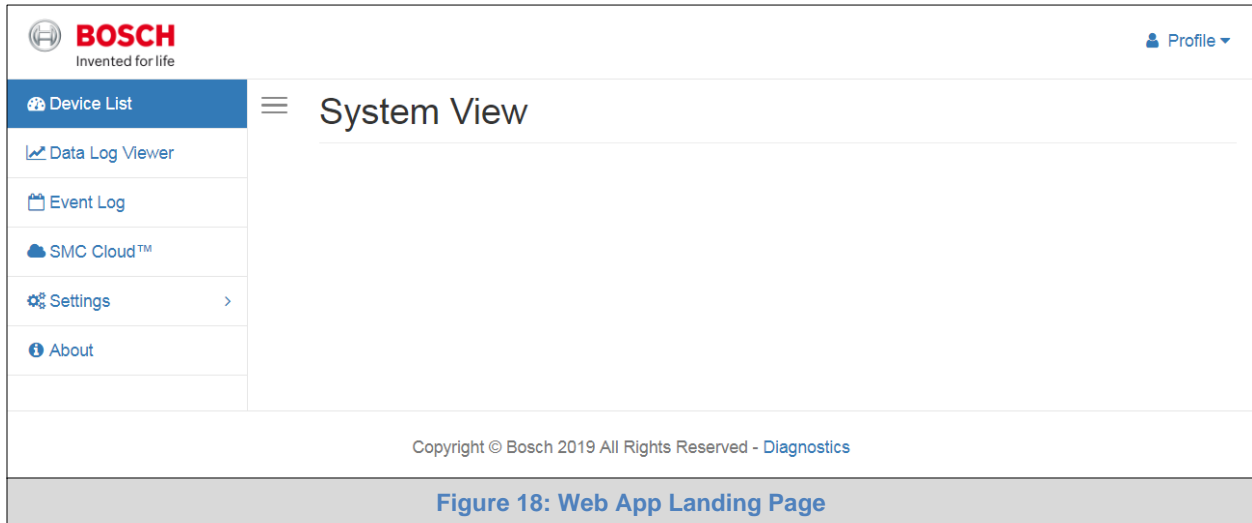

Figure 18: Web App Landing Page

- Then click the Profiles Configuration button to go to the Web Configurator page.

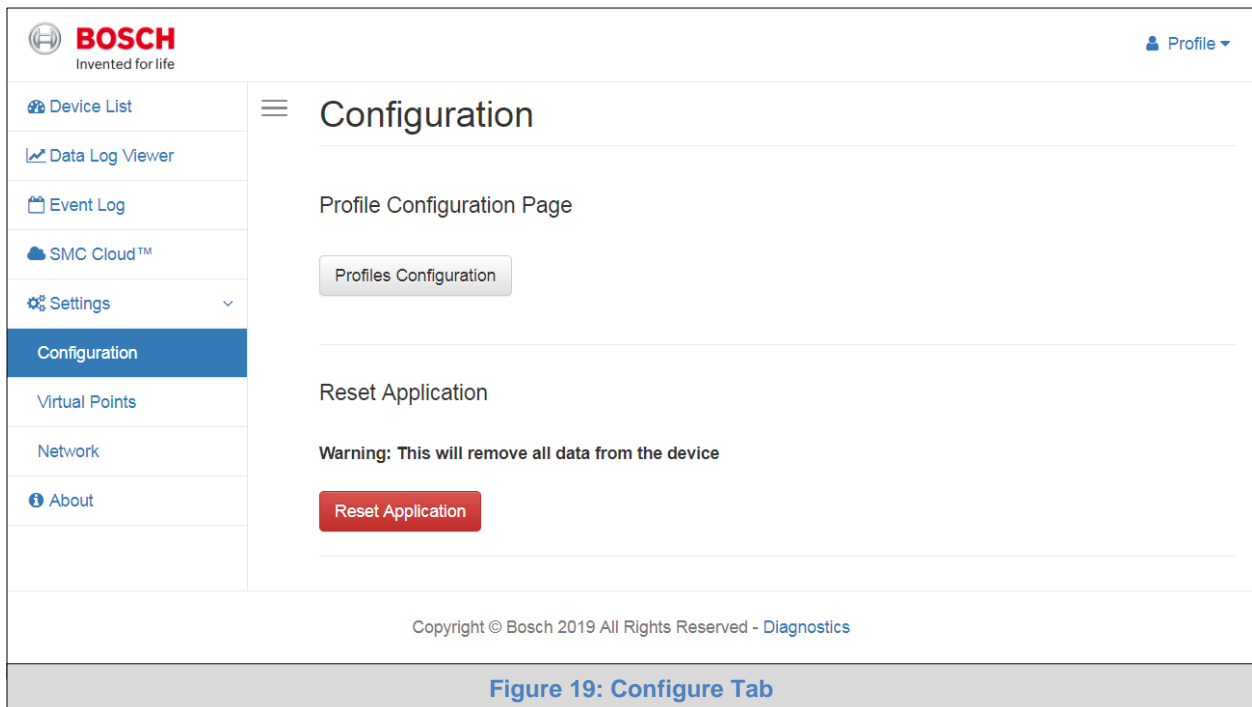



Figure 19: Configure Tab

NOTE: The SMC Cloud™ tab  (see [Figure 19](#)) allows users to connect to the SMC Cloud, MSA Safety’s device cloud solution for IIoT. The SMC Cloud enables secure remote connection to field devices through a FieldServer and its local applications for configuration, management, maintenance. For more information about the SMC Cloud, refer to the [SMC Cloud Start-up Guide](#).

NOTE: For Web App instructions to the System View, Historian, Event Logger and Virtual Points functions, see the [SMC Cloud Start-up Guide](#).

6.2 Select Field Protocol and Set Configuration Parameters

- On the Web Configurator page, the first configuration parameter is the Protocol Selector.

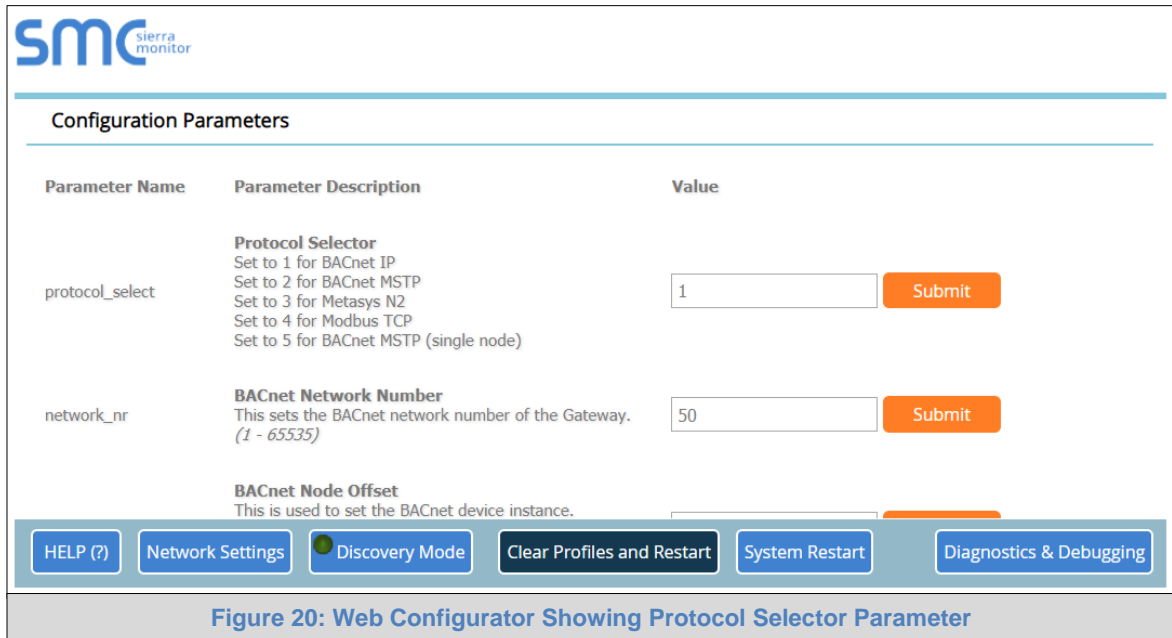

Figure 20: Web Configurator Showing Protocol Selector Parameter

- Select the field protocol by entering the appropriate number into the Protocol Selector Value. Click the Submit button. Click the System Restart button to save the updated configuration.

NOTE: Protocol specific parameters are only visible when the associated protocol is selected.

NOTE: If Modbus TCP/IP was selected and is used for the field protocol, skip Section 6.3. Device profiles are NOT used for Modbus TCP/IP.

- Ensure that all parameters are entered for successful operation of the gateway. Find the legal value options for each parameter under the Parameter Description in parentheses.

NOTE: If multiple devices are connected to the ProtoAir, set the BACnet Virtual Server Nodes field to “Yes”; otherwise leave the field on the default “No” setting.

6.3 Configure Devices Connected to the Gateway

6.3.1 Use Discovery Mode

This configuration method works only with devices set as Auto-Discovery in Section 2.2.

- Click the Discovery Mode button at the bottom of the screen.

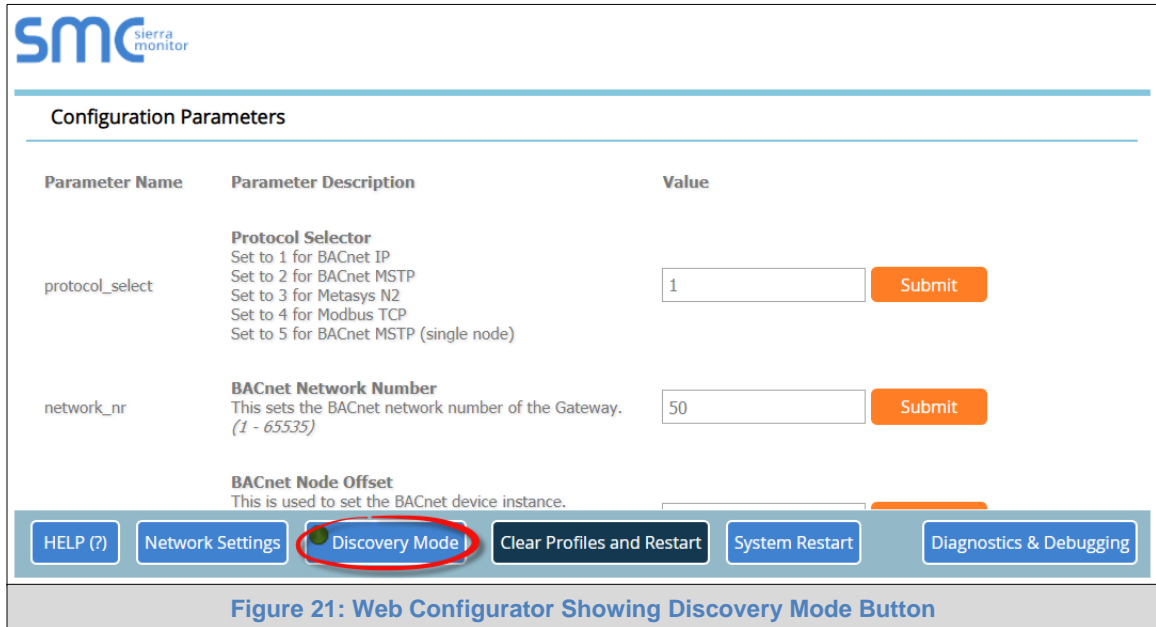

- Click the OK button in the window that appears to discover devices and restart the device.
- Wait for the ProtoAir to restart and the Discovery in Progress window to disappear.

NOTE: It may take about 3 minutes for all the devices to be discovered and the configuration file to be built.

- If the discovery is successful, the desired device profile should appear under the Active profiles title near the bottom of the screen.

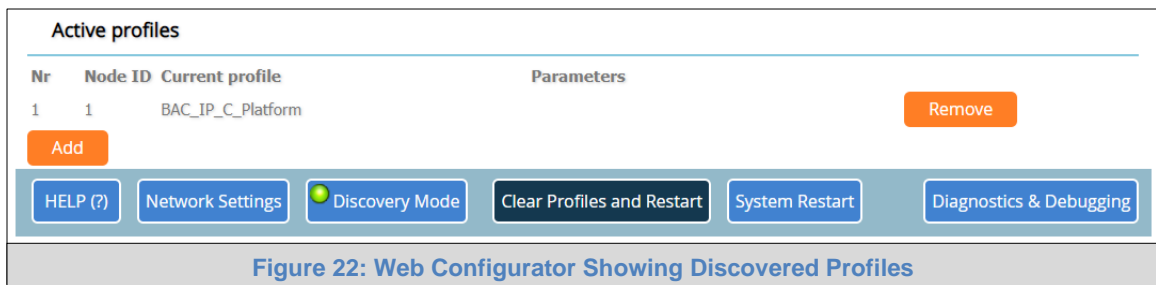

NOTE: Scroll down the page if the Active profiles header is not visible.

6.3.2 Set ProtoAir Active Profiles

This section applies to Web Configurator devices referenced in Section 2.2.

- In the Web Configurator, the Active Profiles are shown below the configuration parameters. The Active Profiles section lists the currently active device profiles, including previous Web Configurator additions and any devices identified by Auto-Discovery configuration methods. This list is empty for new installations, or after clearing all configurations. (Figure 23)

The screenshot displays the 'Configuration Parameters' section of the Web Configurator. It features a table with columns for 'Parameter Name', 'Parameter Description', and 'Value'. Each row includes a text input field and a 'Submit' button. Below the parameters is an 'Active profiles' section with a table listing profiles, including columns for 'Nr', 'Node ID', 'Current profile', and 'Parameters'. At the bottom, there is a navigation bar with buttons for 'HELP (?)', 'Network Settings', 'Discovery Mode', 'Clear Profiles and Restart', 'System Restart', and 'Diagnostics & Debugging'.

Parameter Name	Parameter Description	Value
protocol_select	Protocol Selector Set to 1 for BACnet IP Set to 2 for BACnet MSTP Set to 3 for Metasys N2 Set to 4 for Modbus TCP Set to 5 for BACnet MSTP (single node)	1
network_nr	BACnet Network Number This sets the BACnet network number of the Gateway. (1 - 65535)	50
node_offset	BACnet Node Offset This is used to set the BACnet device instance. The device instance will be sum of the Modbus device address and the node offset. (0 - 4194303)	50000
bac_ip_port	BACnet IP Port This sets the BACnet IP port of the Gateway. The default is 47808. (1 - 65535)	47808
bac_cov_option	BACnet COV This enables or disables COVs for the BACnet connection. Use COV_Enable to enable. Use COV_Disable to disable. (COV_Enable/COV_Disable)	COV_Disable
bac_bbmd_option	BACnet BBMD This enables BBMD on the BACnet IP connection. Use BBMD to enable. Use - to disable. The bdt.ini files also needs to be downloaded. (BBMD/-)	-
bac_virt_nodes	BACnet Virtual Server Nodes Set to NO if the unit is only converting 1 device to BACnet. Set to YES if the unit is converting multiple devices. (No/Yes)	No

Nr	Node ID	Current profile	Parameters
1	1	BAC_IP_C_Platform	

Figure 23: Web Configurator Showing no Active Profiles

- To add an active profile to support a device, click the Add button under the Active Profiles heading. This will present a drop-down menu underneath the Current profile column.
- Once the Profile for the device has been selected from the drop-down list, enter the value of the device’s Node-ID which was assigned in **Section 3.3.2**.

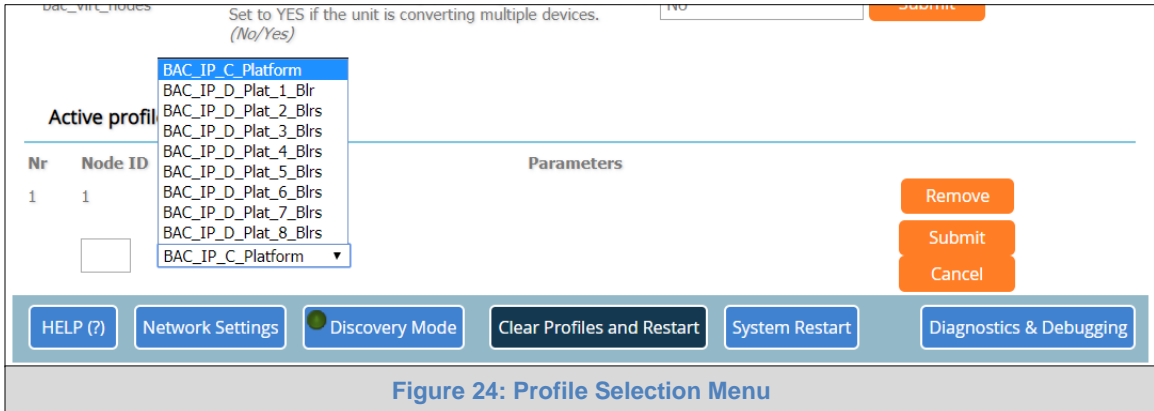

Figure 24: Profile Selection Menu

- Then press the “Submit” button to add the Profile to the list of devices to be configured.
- Repeat this process until all the devices have been added.
- Completed additions are listed under “Active profiles” as shown in **Figure 25**.

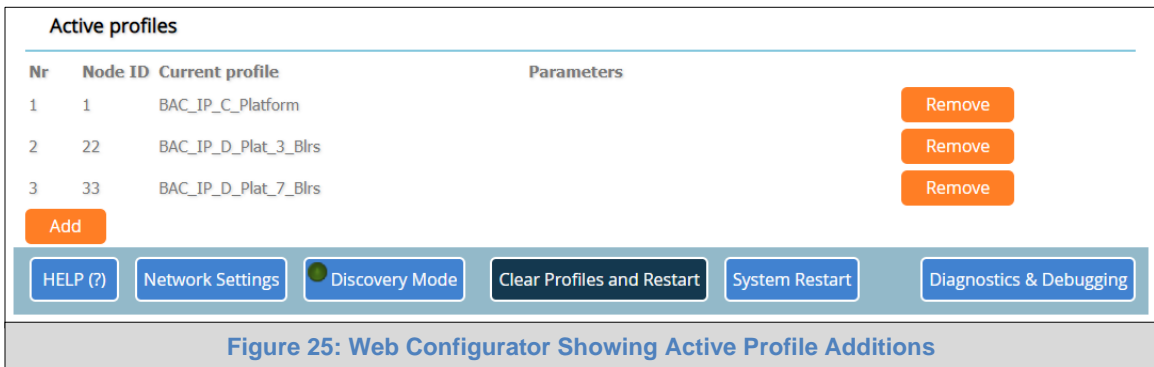

Figure 25: Web Configurator Showing Active Profile Additions

6.4 Verify Device Communications

- **Check that the port R1 TX1 and RX1 LEDs are rapidly flashing.** See **Appendix A.4** for additional information and images.
- Confirm the software shows communication without errors (**Appendix A.2**).

6.5 BACnet: Setting Node_Offset to Assign Specific Device Instances

- Follow the steps outlined in **Section 6.1** to access the ProtoAir Web Configurator.
- The Node_Offset field shows the current value (default = 50,000).
 - The values allowed for a BACnet Device Instance can range from 1 to 4,194,303
- To assign a specific Device Instance (or range); change the Node_Offset value as needed using the calculation below:

$$\text{Device Instance (desired)} = \text{Node_Offset} + \text{Node_ID}$$

For example, if the desired Device Instance for the device 1 is 50,001 and the following is true:

- Device 1 has a Node-ID of 1
- Device 2 has a Node-ID of 22
- Device 3 has a Node-ID of 33

Then plug the device 1's information into the formula to find the desired Node_Offset:

$$50,001 = \text{Node_Offset} + 1$$

➤ **50,000 = Node_Offset**

Once the Node_Offset value is input, it will be applied as shown below:

- Device 1 Instance = 50,000 + Node_ID = 50,000 + 1 = 50,001
- Device 2 Instance = 50,000 + Node_ID = 50,000 + 22 = 50,022
- Device 3 Instance = 50,000 + Node_ID = 50,000 + 33 = 50,033

- Click "Submit" once the desired value is entered.

Figure 26: Web Configurator Node Offset Field

Active profiles			
Nr	Node ID	Current profile	Parameters
1	1	BAC_IP_C_Platform	Remove
2	22	BAC_IP_D_Plat_3_Blrs	Remove
3	33	BAC_IP_D_Plat_7_Blrs	Remove

[Add](#)

[HELP \(?\)](#)
[Network Settings](#)
[Discovery Mode](#)
[Clear Profiles and Restart](#)
[System Restart](#)
[Diagnostics & Debugging](#)

Figure 27: Active Profiles

6.6 How to Start the Installation Over: Clearing Profiles

- Follow the steps outlined in **Section 6.1** to access the ProtoAir Web Configurator.
- At the bottom-left of the page, click the “Clear Profiles and Restart” button.
- Once restart is complete, all past profiles discovered and/or added via Web configurator are deleted. The unit can now be reinstalled.

7 NETWORK SETTINGS

7.1 Navigate to the FS-GUI Network Settings

- Open the FS-GUI page.
 - From the Web App landing page, click the word “Diagnostics” found in blue at the bottom of the screen

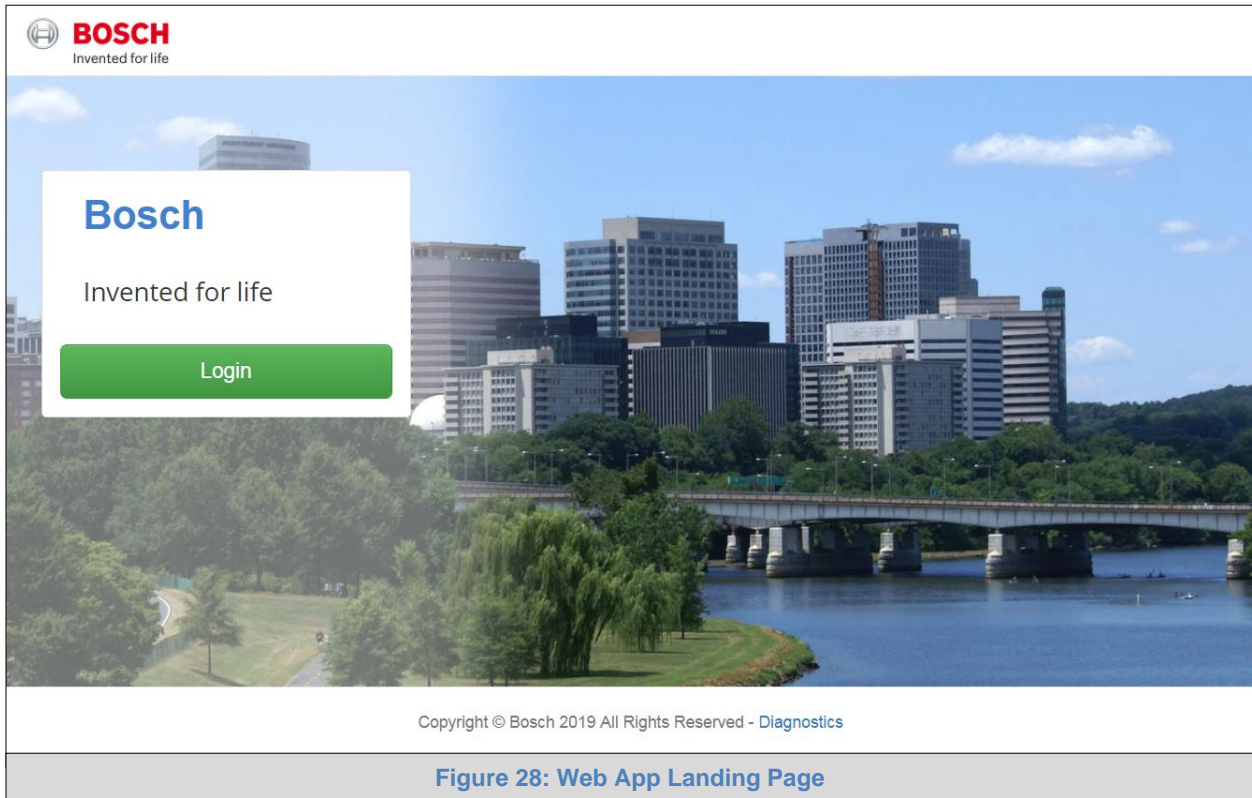

Figure 28: Web App Landing Page

- From the Web Configurator page, click on the blue “Diagnostics & Debugging” button in the bottom right corner of the screen

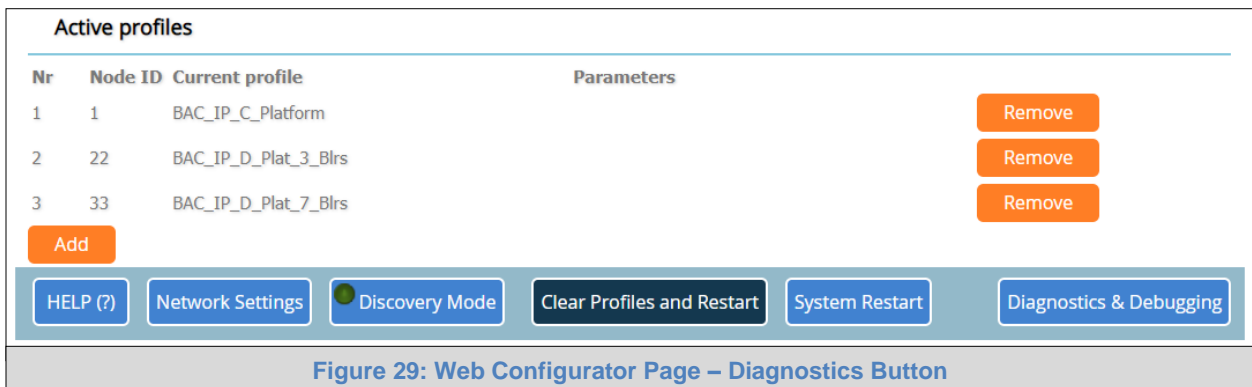

Figure 29: Web Configurator Page – Diagnostics Button

- Find the Navigation tree on the left side of the screen.

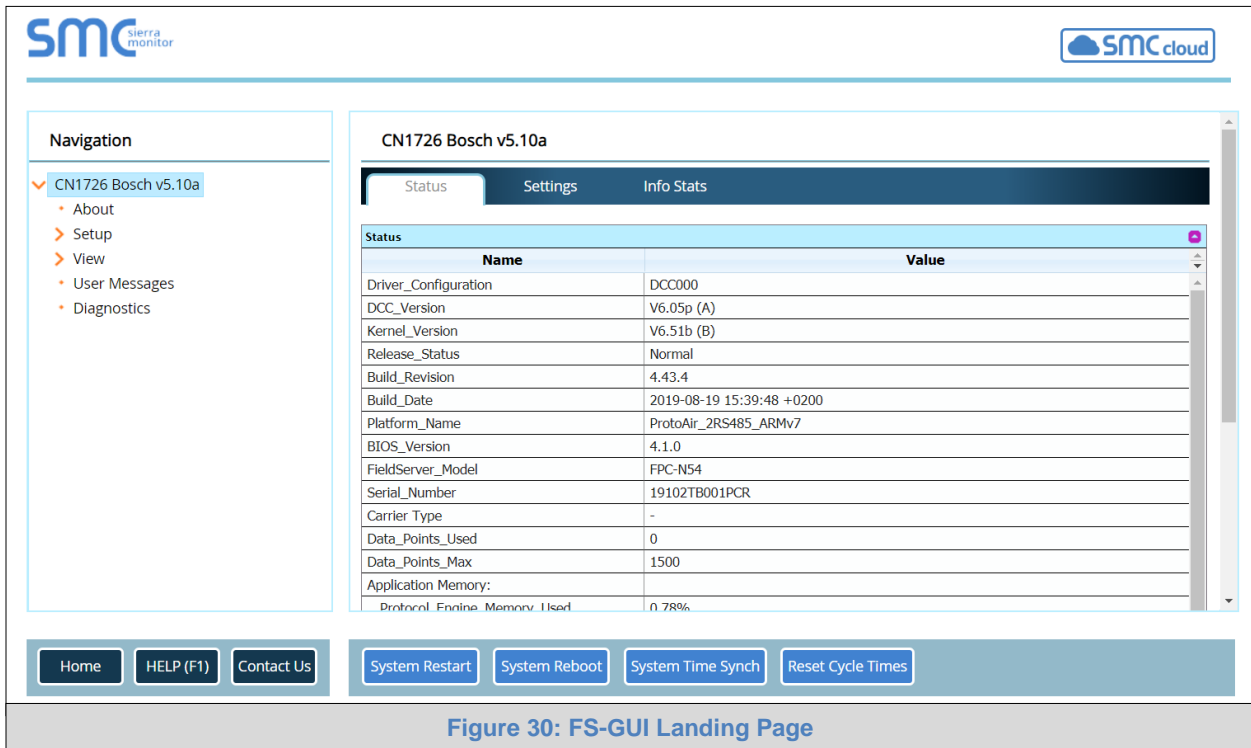

Figure 30: FS-GUI Landing Page

- Click the orange arrow next to the ProtoAir CN number and title to expand the tree.
- Click on the orange arrow next to Setup to expand the tree.
- Click on Network Settings.

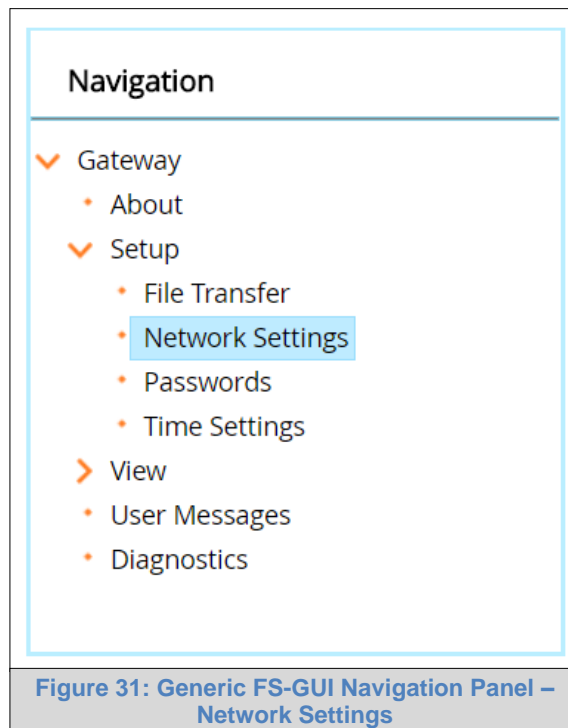

Figure 31: Generic FS-GUI Navigation Panel – Network Settings

7.2 Change the ProtoAir IP Address

Configure the IP settings of the ProtoAir using the following methods:

- When using the Ethernet port to connect to the local network (**Section 7.2.1**).
- When connecting the ProtoAir to a local wireless network, configure the Wi-Fi Client Settings in the ProtoAir (**Section 7.2.2**).

NOTE: For Wi-Fi Access Point network information see [Appendix B.4](#).

7.2.1 Update Wired Network Settings

IP Settings tab is the landing page when selecting Network Settings on the navigation tree. To change the IP settings, follow these instructions:

- Enable DHCP Client State to automatically assign IP Settings or modify the settings manually as needed, via these fields: IP Address, Netmask, Default Gateway and Domain Name Server1/2.

NOTE: If connected to a router, set the Default Gateway to the same IP Address as the router.

- Click Update IP Settings, then click on System Restart to restart the Gateway and activate the new IP Address.
- Connect the ProtoAir to the local network or router.

NOTE: If the FS-GUI was open in a browser, the browser will need to be pointed to the new IP Address of the ProtoAir before the FS-GUI will be accessible again.

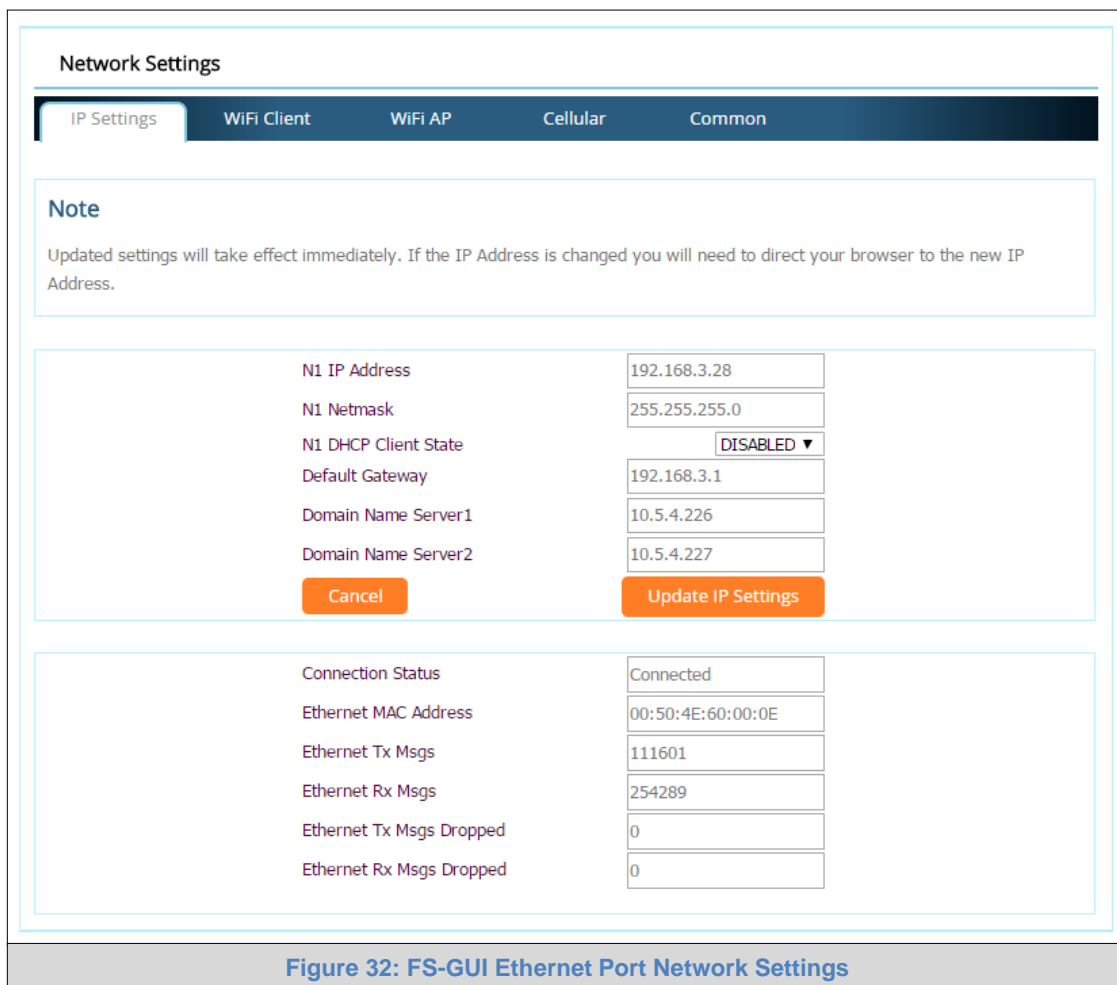

Figure 32: FS-GUI Ethernet Port Network Settings

IP Setting Fields	Definition
Connection Status	Status of connection
MAC Address	Ethernet MAC Address
Tx/Rx Msgs	Number of transmitted and received messages
Tx/Rx Msgs Dropped	Number of unanswered Tx or Rx messages

7.2.2 Update Wi-Fi Client Settings

From the FS-GUI Network Settings landing page, click on the Wi-Fi Client tab. To change the Wi-Fi client settings, follow these instructions:

- Set the Wi-Fi Status to ENABLED for the ProtoAir to communicate with other devices via Wi-Fi.
- Enter the Wi-Fi SSID and Wi-Fi Password for the local wireless network.
- Enable DHCP to automatically assign all Wi-Fi Client network settings or manually modify the setting using the fields immediately below (IP Address, Network, etc.).

NOTE: If connected to a router, set the IP gateway to the same IP Address as the router.

- Click Update Wi-Fi Settings, then click on System Restart to restart the gateway and activate Wi-Fi Client settings.
- **Go to Common settings (Section 7.2.3) to set the Primary Connection to Wi-Fi Client.**

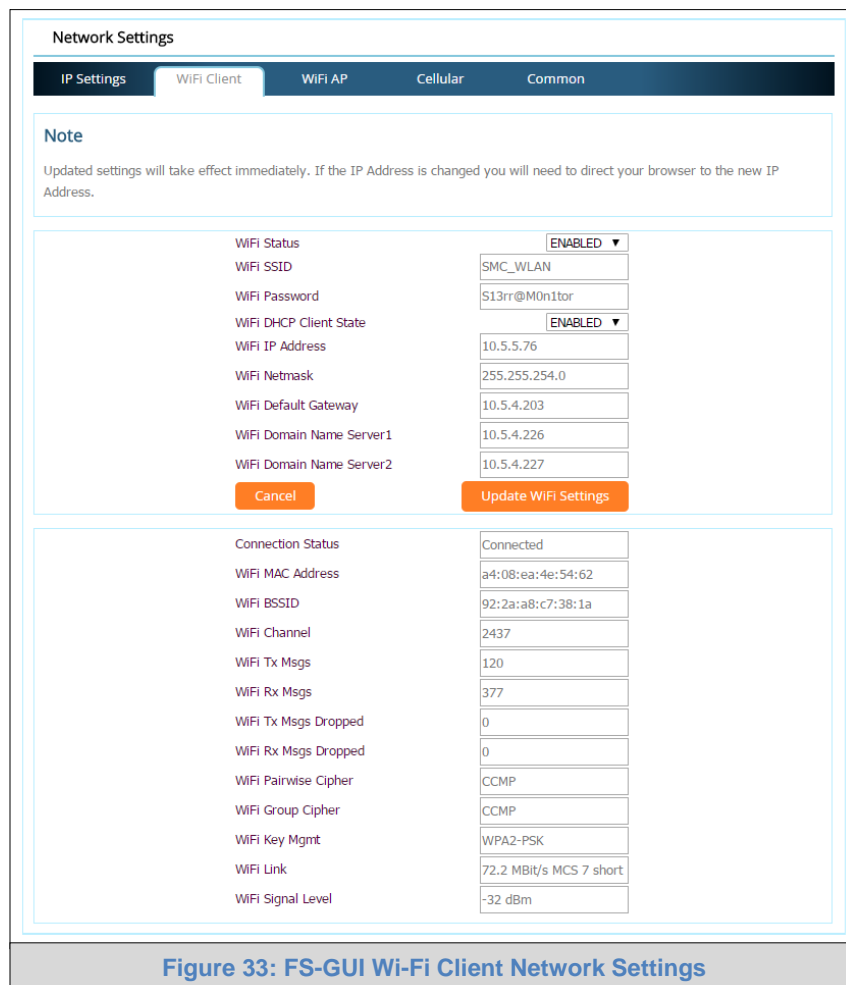

Figure 33: FS-GUI Wi-Fi Client Network Settings

Wi-Fi Client Fields	Definition
Connection Status	Status of connection
MAC Address, BSSID, Channel	Wi-Fi Client MAC Address, BSSID, and Channel
Tx/Rx Msgs	Number of transmitted and received messages
Tx/Rx Msgs Dropped	Number of unanswered Tx or Rx messages
Pairwise Cipher	Type of encryption used for unicast traffic
Group Cipher	Identifies the type of encryption used for multicast / broadcast traffic
Key Mgmt	Encryption type
Link	Connection speed
Signal Level	Signal level in dBm (see Appendix A.6)

7.2.3 Common Settings

The Common Settings make it possible to choose the primary connection when both Ethernet and Wi-Fi Client connections are available.

- From the FS-GUI Network Settings landing page, click on the Common tab.

NOTE: The default Primary Connection is Ethernet.

- Select the desired option from the drop-down menu on the right.
- Click Update Common Settings, then click on System Restart to restart the gateway and activate the new settings.

NOTE: If using Wi-Fi Client and not Ethernet, change Primary Connection to Wi-Fi.

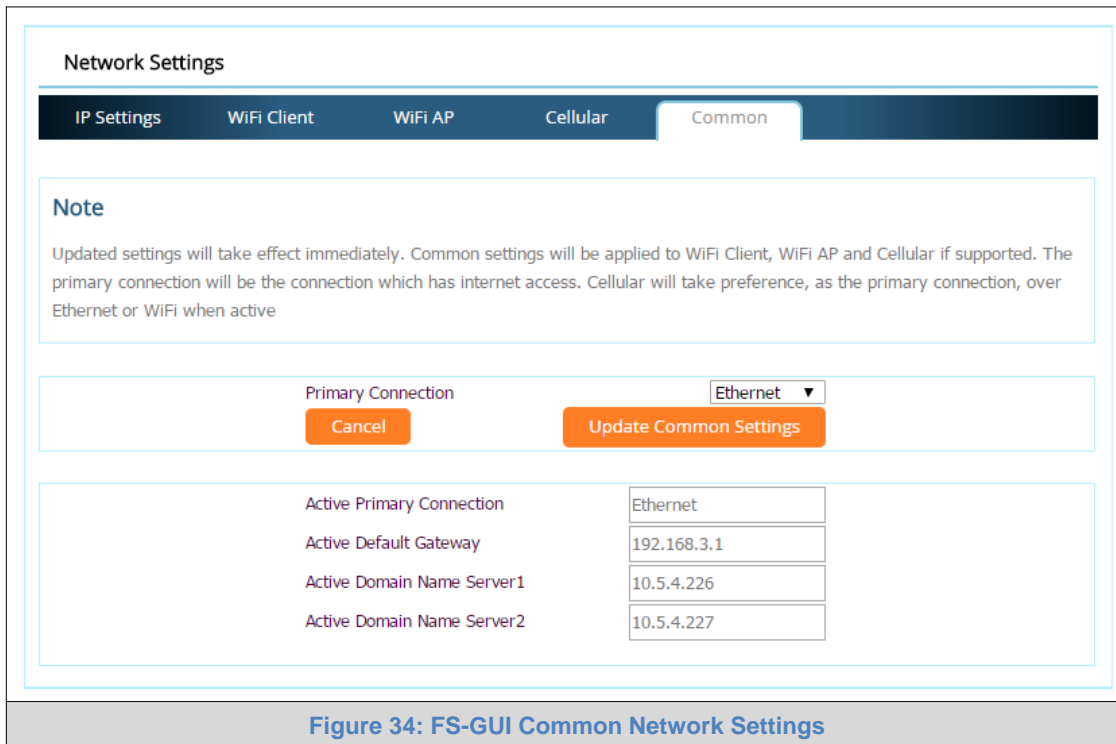

Figure 34: FS-GUI Common Network Settings

NOTE: The fields below the update button show the settings as they were set in the IP Settings or Wi-Fi Client pages. They are not editable on the Common page.

8 SMC CLOUD USER SETUP, REGISTRATION AND LOGIN

8.1 User Setup

Request an invitation to SMC Cloud from the manufacturer’s support team and follow the instructions below to set up login details:

- The “Welcome to SMC Cloud” email will appear as shown below.

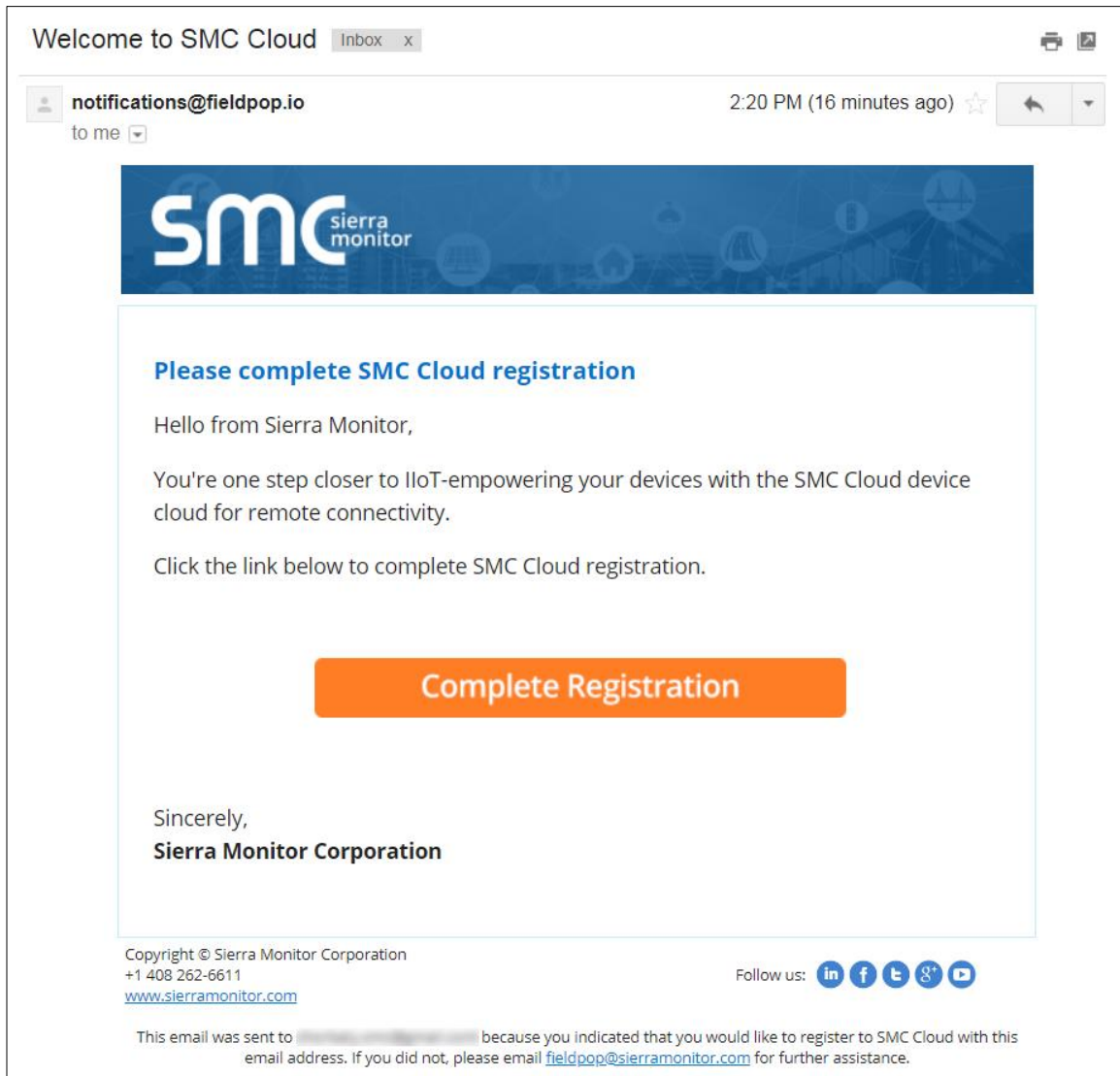

Figure 35: Welcome to SMC Cloud Email

NOTE: If no SMC Cloud email was received, check the spam/junk folder for an email from notification@fieldpop.io. Contact the manufacturer’s support team if the email cannot be found.

- Click the “Complete Registration” button and fill in user details accordingly.

The screenshot shows a registration form titled "Complete Your Registration". It contains the following fields and elements:

- Email Address:** A text input field containing "user@gmail.com".
- First Name:** A text input field with a red asterisk to its right, indicating it is mandatory.
- Last Name:** A text input field with a red asterisk to its right, indicating it is mandatory.
- Phone Number:** A text input field containing "(201) 555-5555" with a small US flag icon to the left. A red asterisk is to its right.
- New Password:** A text input field containing "password" with a red asterisk to its right and an eye icon to toggle visibility.
- Confirm Password:** A text input field containing "password" with a red asterisk to its right and an eye icon to toggle visibility.
- Terms and Service:** A checkbox followed by the text: "By registering my account with SMC, I understand that I am agreeing to the SMC Cloud [Terms of Service](#) and [Privacy Policy](#)". A red asterisk is to the right.
- Legend:** A red asterisk followed by the text "* Mandatory Fields".
- Buttons:** "Save" and "Cancel" buttons at the bottom.

Figure 36: Setting User Details

- Fill in the name, phone number, password fields and click the checkbox to agree to the privacy policy and terms of service.

NOTE: If access to data logs using RESTful API is needed, do not include “#” in the password.

- Click “Save” to save the user details.
- Click “OK” when the Success message appears.
- Record the email account used and password for future use.

8.2 Registration Process

Once SMC Cloud user credentials have been generated, the ProtoAir can be registered onto the SMC Cloud server.

- Click on the SMC Cloud™ tab on the left-hand side of the screen.

The screenshot shows the SMC Cloud web application interface. On the left is a sidebar with navigation options: Device List, Data Log Viewer, Event Log, SMC Cloud™, Settings, and About. The main content area is titled 'System View' and displays three data tables for different platform types.

Name	Address	Location	Description	Supply Temperature	Return Temperature	DHW Temperature	Flue Gas Temperature	System (Heat Exchanger) Temperature	Outside Temperature
LON_C_Platform_1_	1	TBD	TBD	0	0	0	0	0	0

Name	Address	Location	Description	Wr_Sys_SP	Sys_OAT	Sys_Firing_Rate	Sys_SP	Sys_Temp
LON_D_Platform_3_Blrs_22_	22	TBD	TBD	0	0	0	0	0

Name	Address	Location	Description	Wr_Sys_SP	Sys_OAT	Sys_Firing_Rate	Sys_SP	Sys_Temp
LON_D_Platform_7_Blrs_33_	33	TBD	TBD	0	0	0	0	0

Copyright © Bosch 2019 All Rights Reserved - Diagnostics

Figure 37: Web App Landing Page – SMC Cloud Tab

- The following informational splash page will appear, click Close to view the registration page.

The splash page features the following text and elements:

Securely access your FieldServer from anywhere with the **SMC Cloud™ device cloud**

Your One Stop for Managing Your Devices and Users

- **Secure Remote Access**
Securely connect your field devices SMC Cloud™
- **Device Management**
Manage all your FieldServers and connected devices from SMC Cloud™ and upgrade firmware remotely
- **User Management**
Set up your user personnel with the right security permissions and device assignments for users to diagnose, configure, and better support the field installation.

For more information about SMC Cloud™, visit [our website](#).

Close

Do not show this page again

The page includes a map of North America and the Caribbean with several location pins. The SMC Cloud logo is in the bottom left corner of the map area.

Figure 38: Registration Information Page

- If a warning message appears instead of the splash page, follow the suggestion that appears on screen.
- If the ProtoAir cannot reach the SMC Cloud server, the following message will appear.

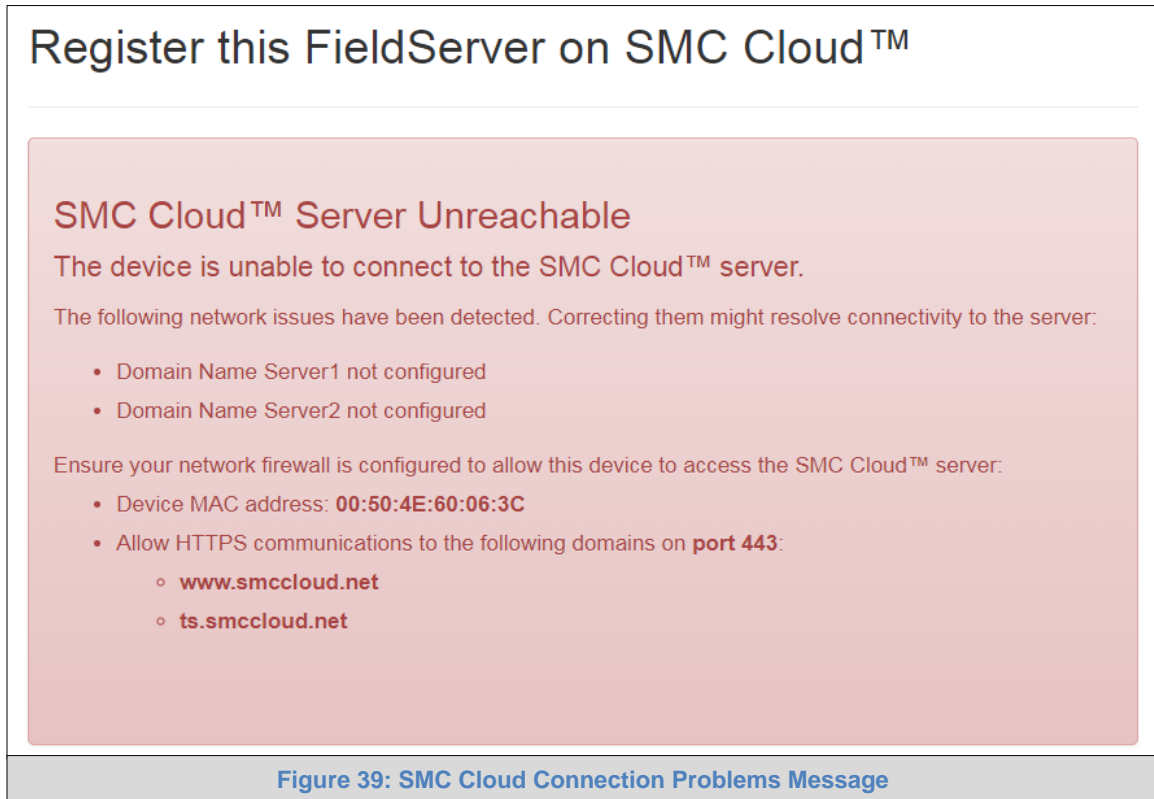

- Follow the directions presented in the warning message and check that the DNS settings are set up with the following Domain Name Server (DNS) settings:
 - DNS1=8.8.8.8
 - DNS2=8.8.4.4
- Ensure that the ProtoAir is properly connected to the Internet

NOTE: If changes to the network settings are done, remember to click “Update IP Settings” and then power cycle the ProtoAir.

- On the registration page, fill in user credentials and all other device information fields for registration of each individual ProtoAir in the field.

Figure 40: SMC Cloud Registration Page

- To input the device location, do one of the following:
 - Enter the address in the address field
 - Click the “Get Current Location” button to auto-populate

NOTE: This button will only work if location services have been enabled on the local browser. If using the Chrome browser and connected via LAN, this method will not work.

- Drop a location directly on the Google map
- Enter the latitude and longitude manually
- Click Register Device.

- Once the device has successfully been registered, the following screen will appear listing the device details and additional information auto-populated by the ProtoAir.



8.3 Login to SMC Cloud

After the ProtoAir is registered, go to www.smccloud.net and type in the appropriate login information as per registration credentials.

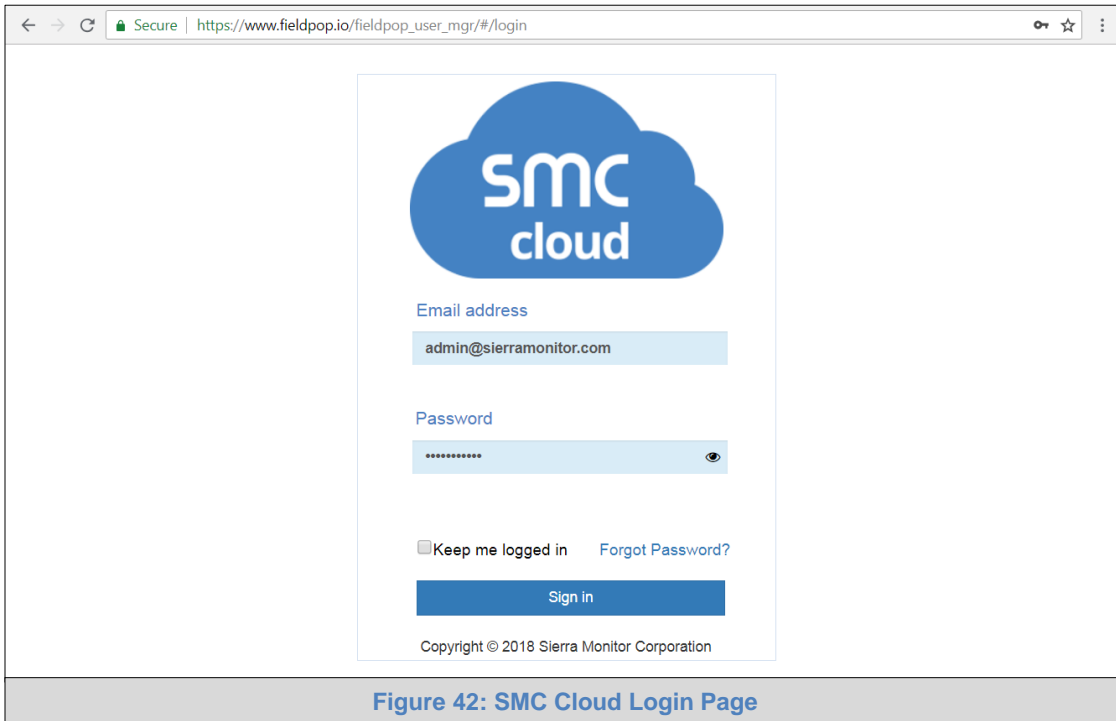

Figure 42: SMC Cloud Login Page

NOTE: If the login password is lost, see the [SMC Cloud Start-up Guide](#) for recovery instructions.

On first login, the Privacy Policy window will appear. Read the Terms of Service, click the checkbox to accept the terms and then click the Continue button to access SMC Cloud.

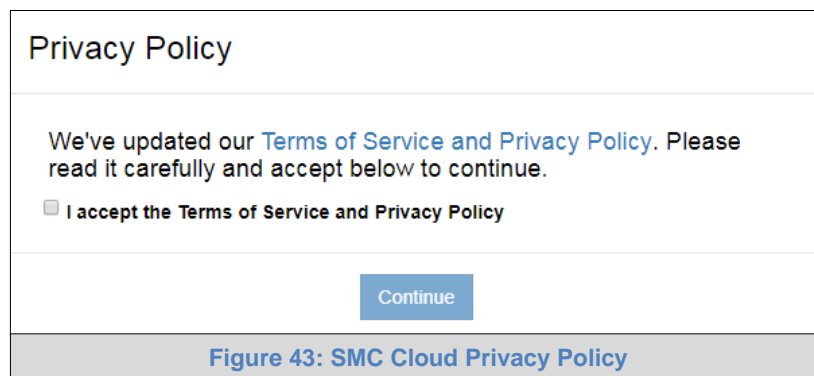

Figure 43: SMC Cloud Privacy Policy

NOTE: For additional SMC Cloud instructions see the [SMC Cloud Start-up Guide](#).

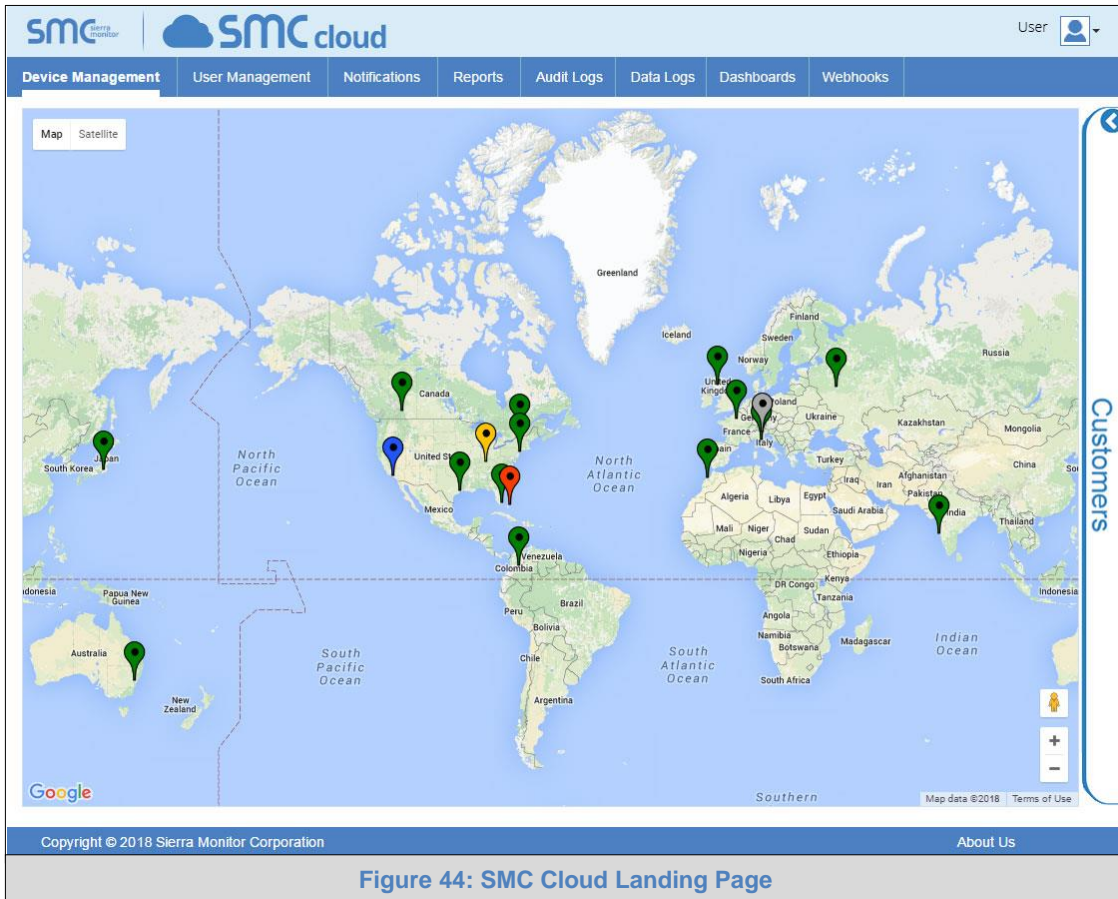
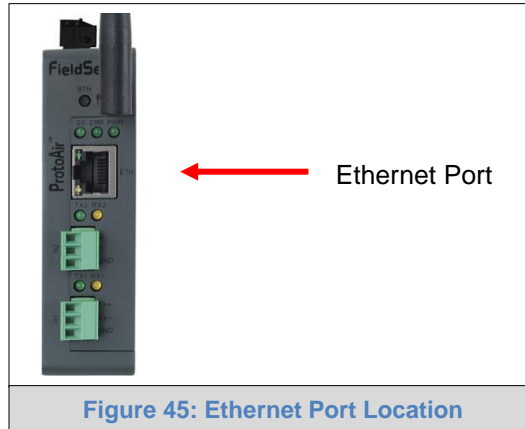

Figure 44: SMC Cloud Landing Page

Appendix A Troubleshooting

Appendix A.1 Lost or Incorrect IP Address

- Ensure that FieldServer Toolbox is loaded onto the local PC. Otherwise, download the FieldServer-Toolbox.zip via the Sierra Monitor website's [Software Downloads](#).
- Extract the executable file and complete the installation.



- Connect a standard Cat-5 Ethernet cable between the user's PC and ProtoAir.
- Double click on the FS Toolbox Utility and click Discover Now on the splash page.
- Check for the IP Address of the desired gateway.

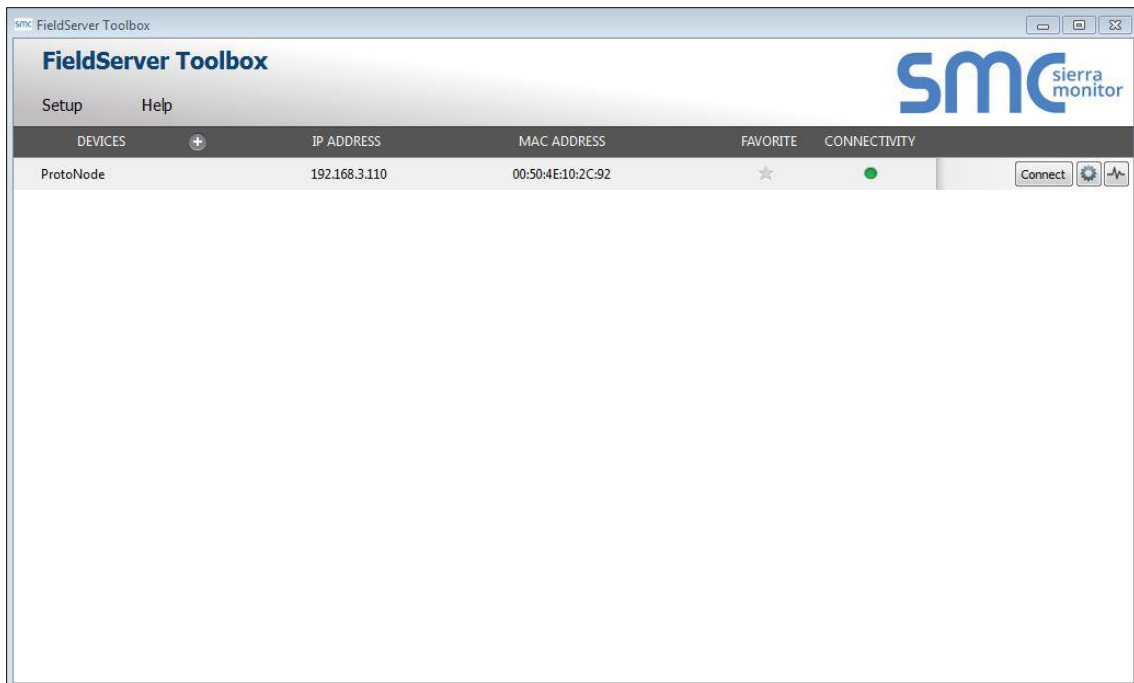

- If correcting the IP Address of the gateway: click the settings icon  on the same row as the gateway, then click Network Settings, change the IP Address and click Update IP Settings to save.

Appendix A.2 Viewing Diagnostic Information

- Type the IP Address of the ProtoAir into the web browser or use the FieldServer Toolbox to connect to the ProtoAir.
- Click on Diagnostics Button, then click on view, and then on connections.
- If there are any errors showing on the Connections page, refer to [Appendix A.3](#) to check the wiring and settings.

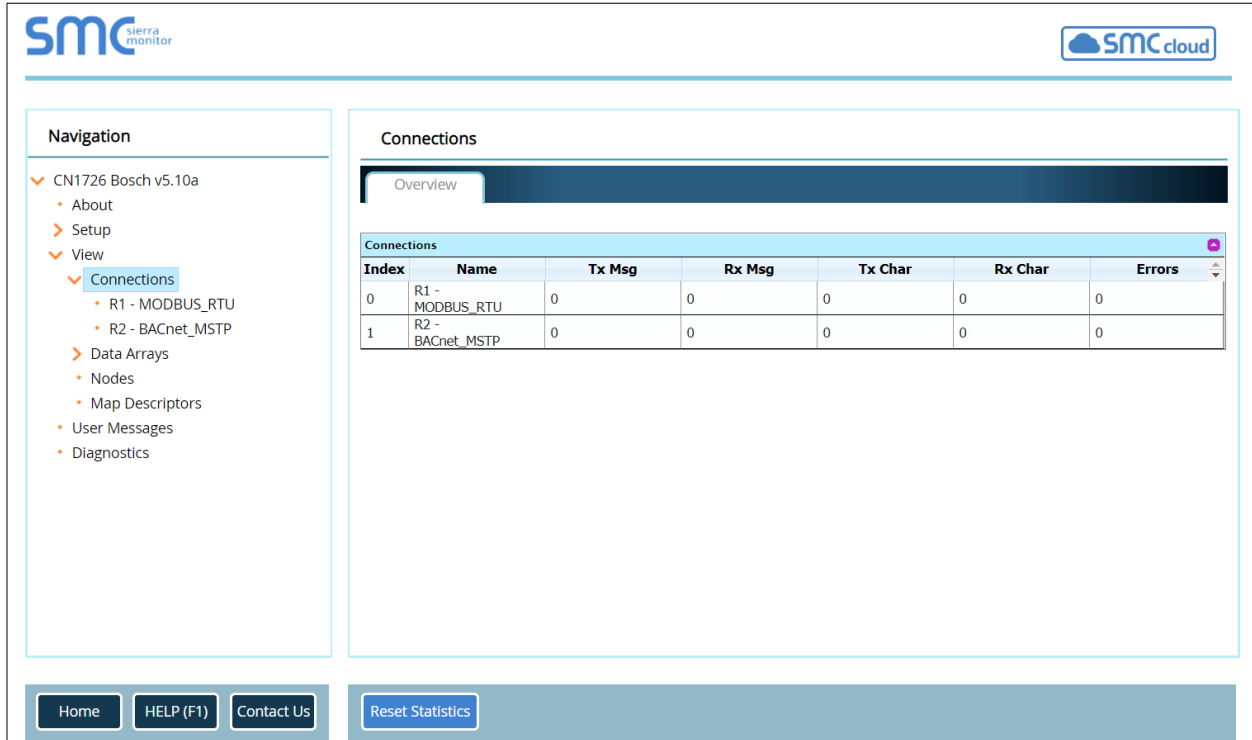

Figure 46: Error Messages Screen

Appendix A.3 Checking Wiring and Settings

- No COMS on Modbus RTU side. If the Tx/Rx LEDs are not flashing rapidly then there is a COM issue. To fix this, check the following:
 - Visual observations of LEDs on ProtoAir ([Appendix A.4](#))
 - Check baud rate, parity, data bits, stop bits
 - Check Detector ID matches the correct device
 - Verify wiring
 - Verify the device was listed under the Web Configurator Active Profiles ([Section 6.3](#))
- Field COM problems:
 - Visual observations of LEDs on the ProtoAir ([Appendix A.4](#))
 - Verify IP Address setting
 - Verify wiring

NOTE: If the problem still exists, a Diagnostic Capture needs to be taken and sent to technical support. ([Appendix A.5](#))

Appendix A.4 LED Diagnostics for Communications Between ProtoAir and Devices

See the diagram below for ProtoAir FPA-W44 LED Locations.

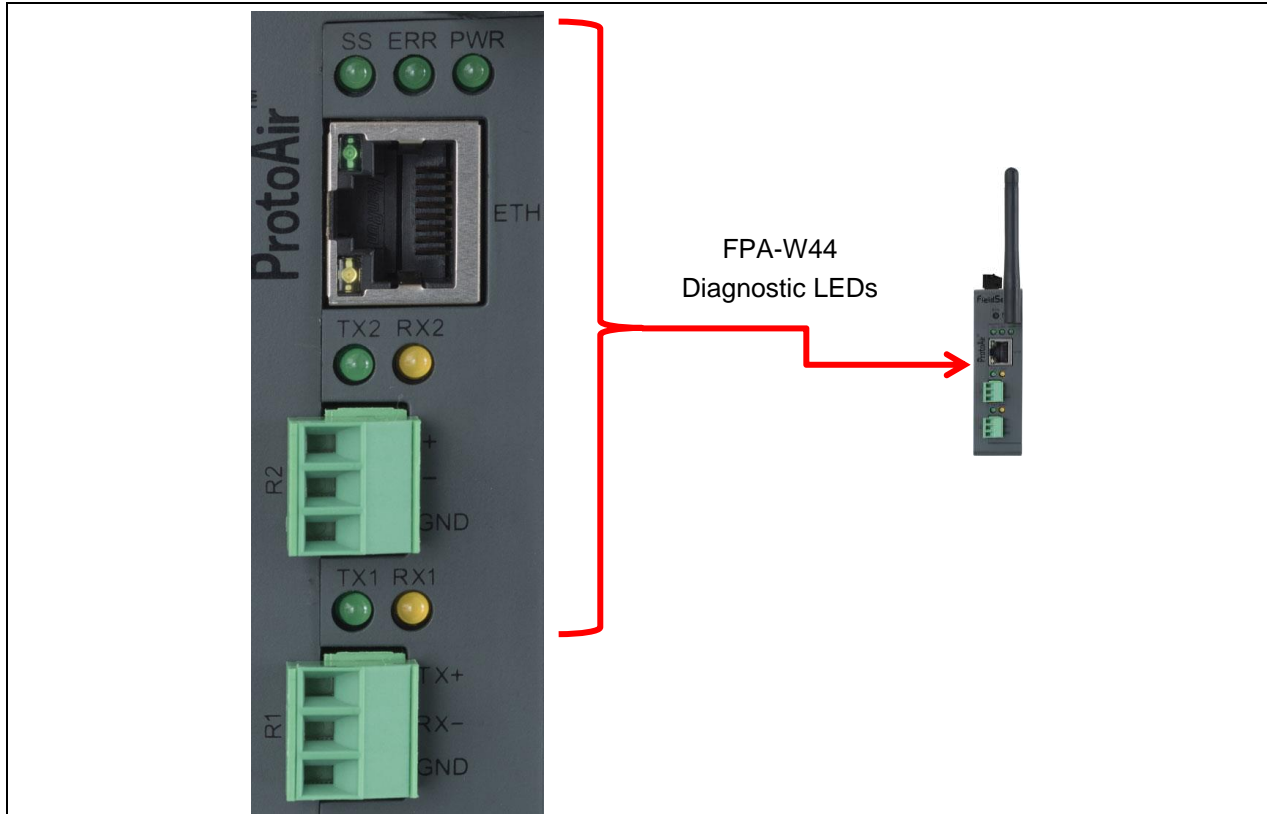

Tag	Description
SS	The SS LED will flash once a second to indicate that the bridge is in operation.
ERR	The SYS ERR LED will go on solid indicating there is a system error. If this occurs, immediately report the related "system error" shown in the error screen of the FS-GUI interface to support for evaluation.
PWR	The power light should always show steady green when connected to a functioning power source.
RX	The RX LED will flash when a message is received on the serial port on the 3-pin connector. If the serial port is not used, this LED is non-operational. RX1 applies to the R1 connection while RX2 applies to the R2 connection.
TX	The TX LED will flash when a message is sent on the serial port on the 3-pin connector. If the serial port is not used, this LED is non-operational. TX1 applies to the R1 connection while TX2 applies to the R2 connection.

Figure 47: Diagnostic LEDs

Appendix A.5 Taking a FieldServer Diagnostic Capture

When there is a problem on-site that cannot easily be resolved, perform a diagnostic capture before contacting support so that support can quickly solve the problem. There are two methods for taking diagnostic captures:

- **FieldServer Toolbox:**

This method requires installation of the FS Toolbox program. A FS Toolbox diagnostic capture takes a snapshot of the loaded configuration files and a log of all the communications on the serial ports over a specified period of time. If the problem occurs over an Ethernet connection, then take a Wire Shark capture.

- **Gateway's FS-GUI Page:**

This method doesn't require downloading software. The diagnostic capture utilities are embedded in the FS-GUI web interface. Starting a diagnostic capture takes a snapshot of the loaded configuration files and a log of all the communications over a specified period of time. This works for both serial and Ethernet connections.

NOTE: The information in the zipped files contains everything support needs to quickly resolve problems that occur on-site.

Appendix A.5.1 Using the FieldServer Toolbox

Once the Diagnostic Capture is complete, email it to technical support. The Diagnostic Capture will accelerate diagnosis of the problem.

- Ensure that FieldServer Toolbox is loaded onto the local PC. Otherwise, download the FieldServer-Toolbox.zip via the Sierra Monitor website's [Software Downloads](#).
- Extract the executable file and complete the installation.

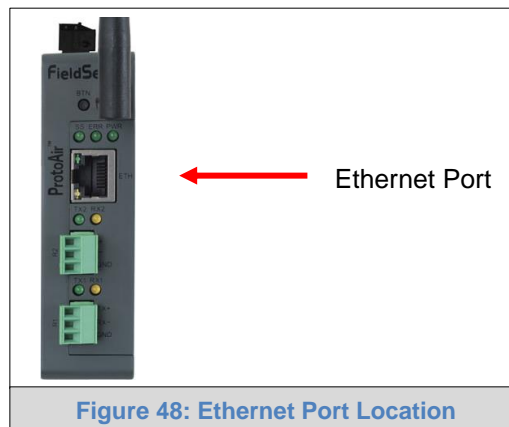
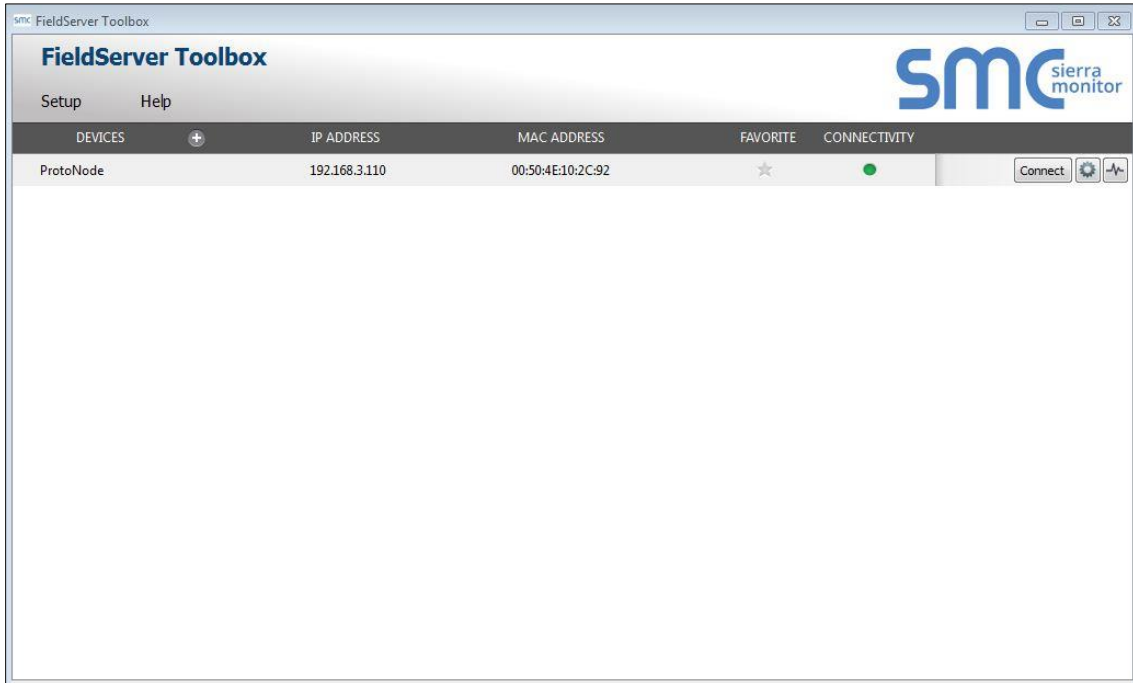

Figure 48: Ethernet Port Location

- Connect a standard Cat-5 Ethernet cable between the PC and ProtoAir.
- Double click on the FS Toolbox Utility.

- **Step 1: Take a Log**

- Click on the diagnose icon  of the desired device



- Ensure "Full Diagnostic" is selected (this is the default)

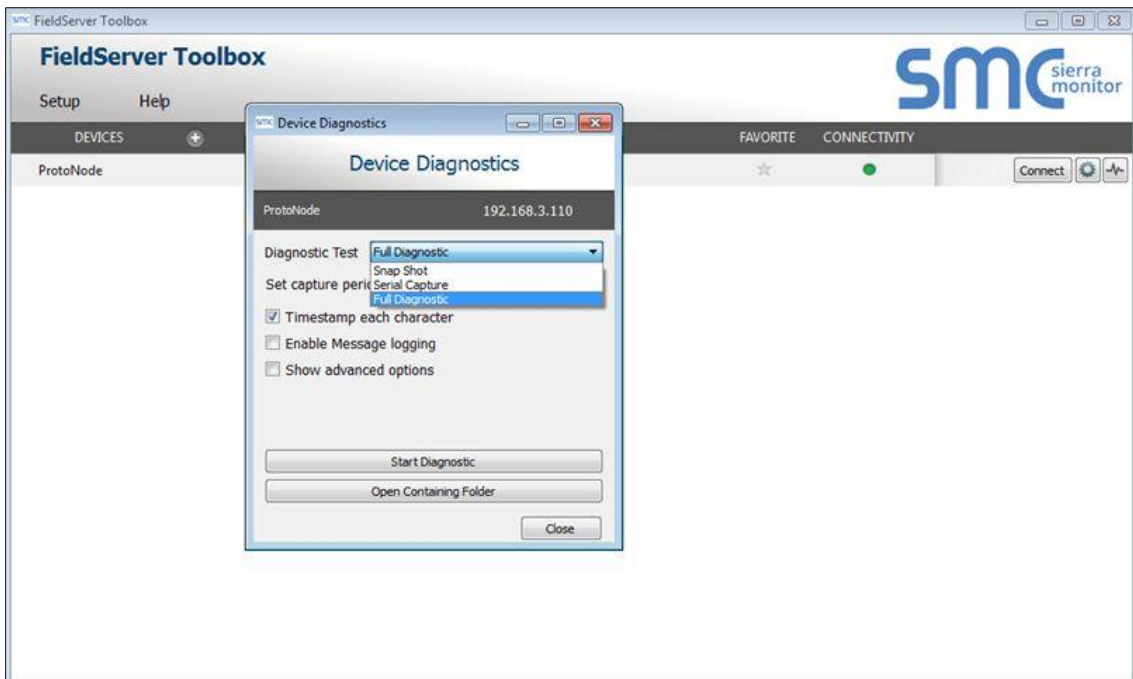

NOTE: If desired, the default capture period can be changed.

- Click on “Start Diagnostic”

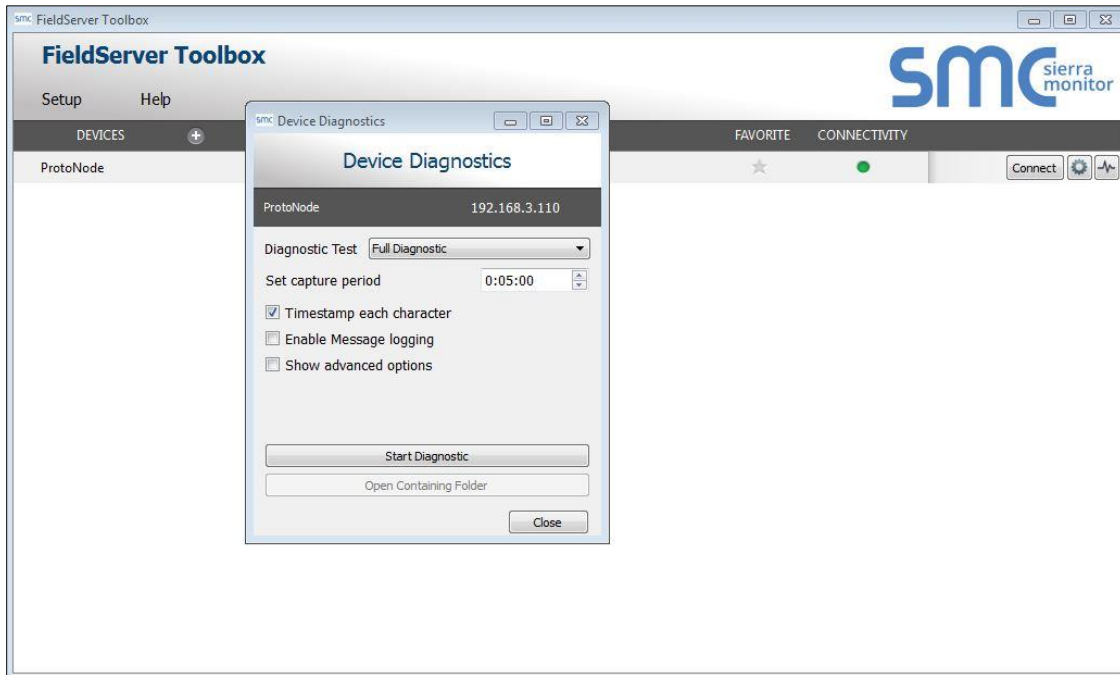

- Wait for Capture period to finish, then the Diagnostic Test Complete window will appear
- **Step 2: Send Log**
 - Once the Diagnostic test is complete, a .zip file is saved on the PC

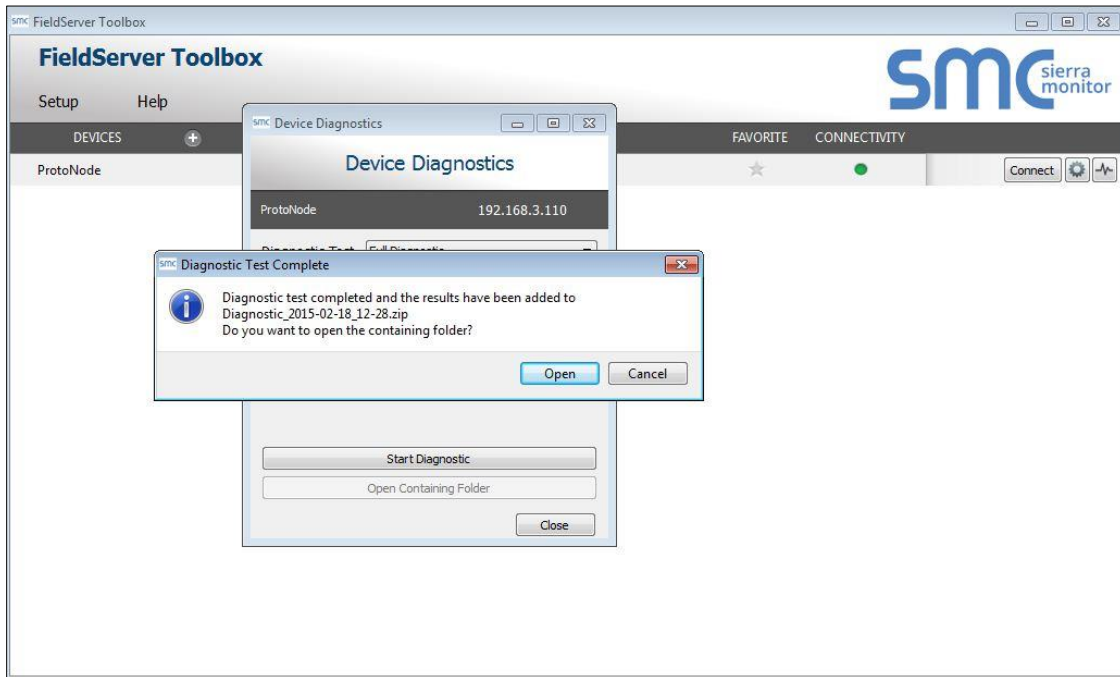

- Choose “Open” to launch explorer and have it point directly at the correct folder
- Send the Diagnostic zip file to technical support



Appendix A.5.2 Using FS-GUI

Diagnostic Capture via FS-GUI is only available on FieldServers with a bios updated/released on November 2017 or later. Completing a Diagnostic Capture through the FieldServer allows network connections (such as Ethernet and Wi-Fi) to be captured.

Once the Diagnostic Capture is complete, email it to technical support. The Diagnostic Capture will accelerate diagnosis of the problem.

- Open the FieldServer FS-GUI page.
- Click on Diagnostics in the Navigation panel.

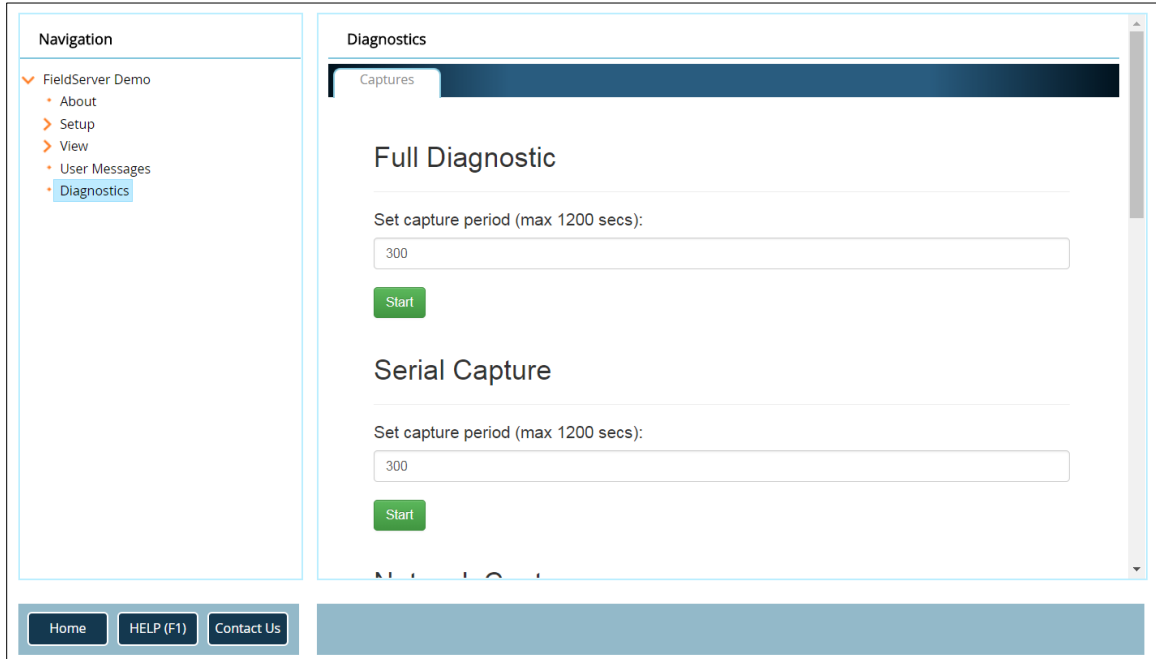

- Go to Full Diagnostic and select the capture period.
- Click the Start button under the Full Diagnostic heading to start the capture.
 - When the capture period is finished, a Download button will appear next to the Start button

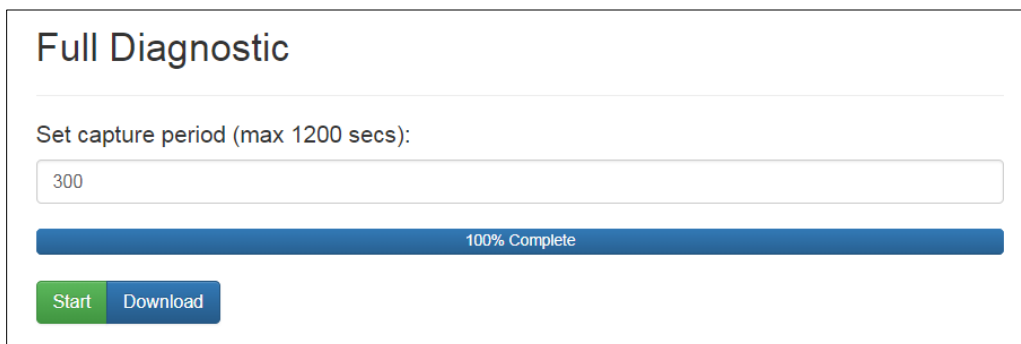

- Click Download for the capture to be downloaded to the local PC.
- Send the diagnostic zip file to technical support.

NOTE: Diagnostic captures of BACnet MS/TP communication are output in a “.PCAP” file extension which is compatible with Wireshark.

Appendix A.6 Wi-Fi Signal Strength

Wi-Fi
<60dBm – Excellent
<70dBm – Very good
<80dBm – Good
>80dBm – Weak
Figure 49: Wi-Fi Signal Strength Listing

NOTE: If the signal is weak or spotty, try to improve the signal strength by checking the antenna and the ProtoAir position.

Appendix A.7 Factory Reset Instructions

For instructions on how to reset a FieldServer back to its factory released state, see [ENOTE - FieldServer Next Gen Recovery](#).

Appendix A.8 Internet Browsers Not Supported

- Internet Explorer

NOTE: Internet Explorer is no longer supported as recommended by Microsoft. Please use the latest version of Chrome, Firefox or Edge.

Appendix B Additional Information

Appendix B.1 Updating Firmware

To load a new version of the firmware, follow these instructions:

1. Extract and save the new file onto the local PC.
2. Open a web browser and type the IP Address of the FieldServer in the address bar.
 - o Default IP Address is 192.168.1.24
 - o Use the FS Toolbox utility if the IP Address is unknown ([Appendix A.1](#))
3. Click on the “Diagnostics & Debugging” button.
4. In the Navigation Tree on the left-hand side, do the following:
 - a. Click on “Setup”
 - b. Click on “File Transfer”
 - c. Click on the “General” tab
5. In the General tab, click on “Choose Files” and select the web.img file extracted in step 1.
6. Click on the orange “Submit” button.
7. When the download is complete, click on the “System Restart” button.

Appendix B.2 BACnet: Setting Network_Number for More Than One ProtoAir on the Subnet

For both BACnet MS/TP and BACnet/IP, if more than one ProtoAir is connected to the same subnet, they must be assigned unique Network_Number values.

On the main Web Configuration screen, update the BACnet Network Number field and click submit. The default value is 50.

network_nr	BACnet Network Number This sets the BACnet network number of the Gateway. (1 - 65535)	<input type="text" value="50"/>	<input type="button" value="Submit"/>
------------	--	---------------------------------	---------------------------------------

Figure 50: Web Configurator – Network Number Field

Appendix B.3 Securing ProtoAir with Passwords

Access to the ProtoAir can be restricted by enabling a password on the FS-GUI Passwords page – click Setup and then Passwords in the navigation panel. There are 2 access levels defined by 2 account names: Admin and User.

- The Admin account has unrestricted access to the ProtoAir.
- The User account can view any ProtoAir information but cannot make any changes or restart the ProtoAir.

The password needs to be a minimum of eight characters and **is case sensitive**.

If the password is lost, click cancel on the password authentication popup window, and email the password recovery token to technical support to receive a temporary password from the customer support team. Access the ProtoAir to set a new password.

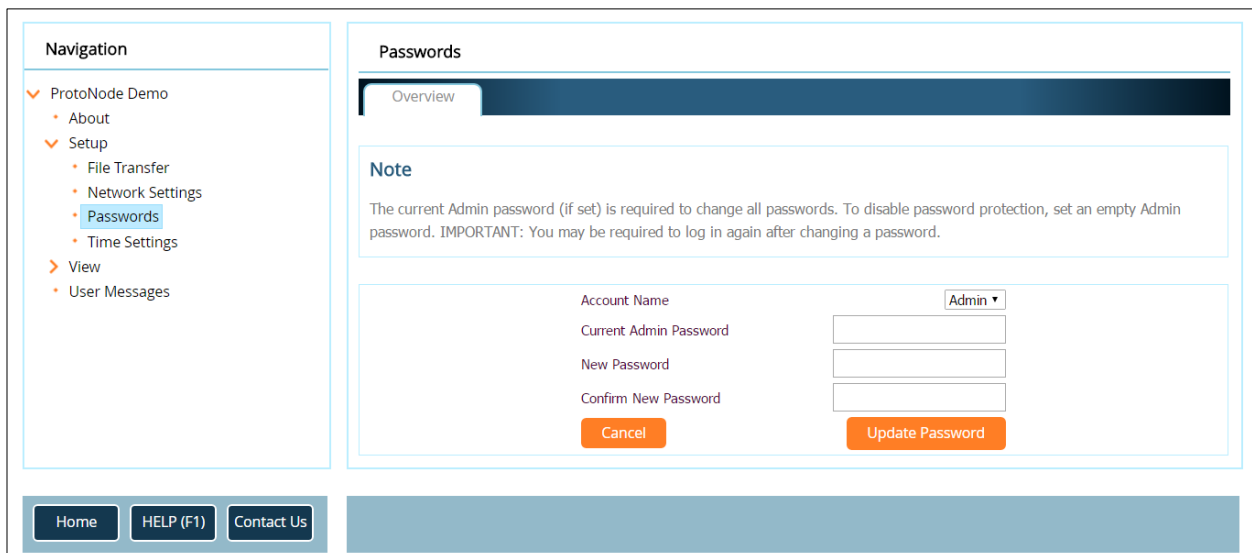

Figure 51: FS-GUI Passwords Page

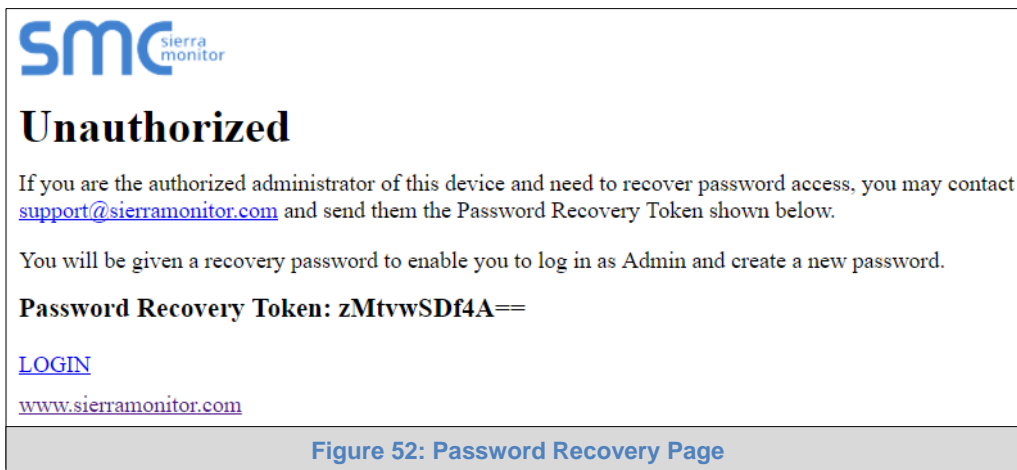

Figure 52: Password Recovery Page

Appendix B.4 Wi-Fi Access Point Network Settings

From the FS-GUI Network Settings landing page, click on the Wi-Fi AP tab. To change the Wi-Fi AP settings, follow these instructions:

- The Access Point Status Field must be ENABLED to allow connecting to the ProtoAir via Wi-Fi.
- Modify the Settings manually as needed, via these fields: Access Point SSID, Access Point Password, SSID Broadcast, and Channel.

NOTE: The default channel is 11. The default IP Address is 192.168.50.1.

- Click Update Wi-Fi Settings, then click on the System Restart to restart the Gateway and activate the Wi-Fi settings.

NOTE: If the FS-GUI was open in a browser via Wi-Fi, the browser will need to be updated with the new Wi-Fi details before the ProtoAir FS-GUI will be accessible again.

The screenshot shows the 'Network Settings' interface with the 'WiFi AP' tab selected. A note indicates that settings take effect immediately and that SSID broadcast must be enabled for discovery. The configuration fields are as follows:

Field	Value
Access Point Status	ENABLED
Access Point SSID	ProtoAir-60000E
Access Point Password	12345678
SSID Broadcast	ENABLED
Channel	11
Access Point IP Address	192.168.50.1
Access Point Netmask	255.255.255.0
Access Point IP Pool Address Start	192.168.50.120
Access Point IP Pool Address End	192.168.50.130
Connection Status	Enabled
Access Point MAC Address	a4:08:ea:4e:54:62
Access Point Tx Msgs	0
Access Point Rx Msgs	0
Access Point Tx Msgs Dropped	0
Access Point Rx Msgs Dropped	0

Figure 53: FS-GUI Wi-Fi AP Network Settings

Wi-Fi AP Fields	Definition
Connection Status	Status of connection
MAC Address	Access point's MAC Address
Tx/Rx Msgs	Number of transmitted and received messages
Tx/Rx Msgs Dropped	Number of unanswered Tx or Rx messages

Appendix B.5 Mounting

The ProtoAir can be mounted using the DIN rail mounting bracket on the back of the unit.

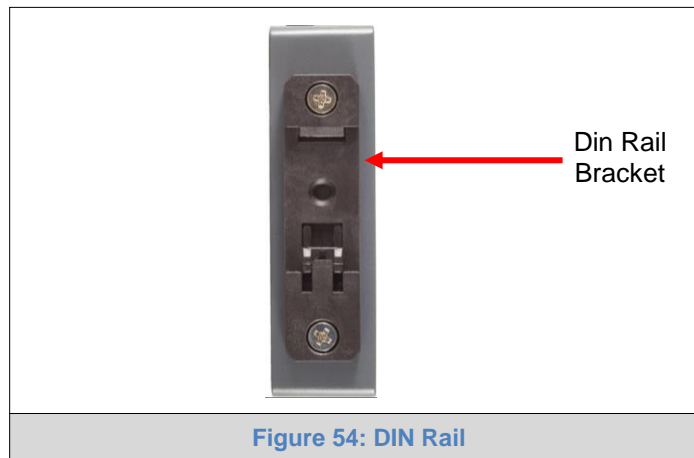

Appendix B.6 Physical Dimension Drawing

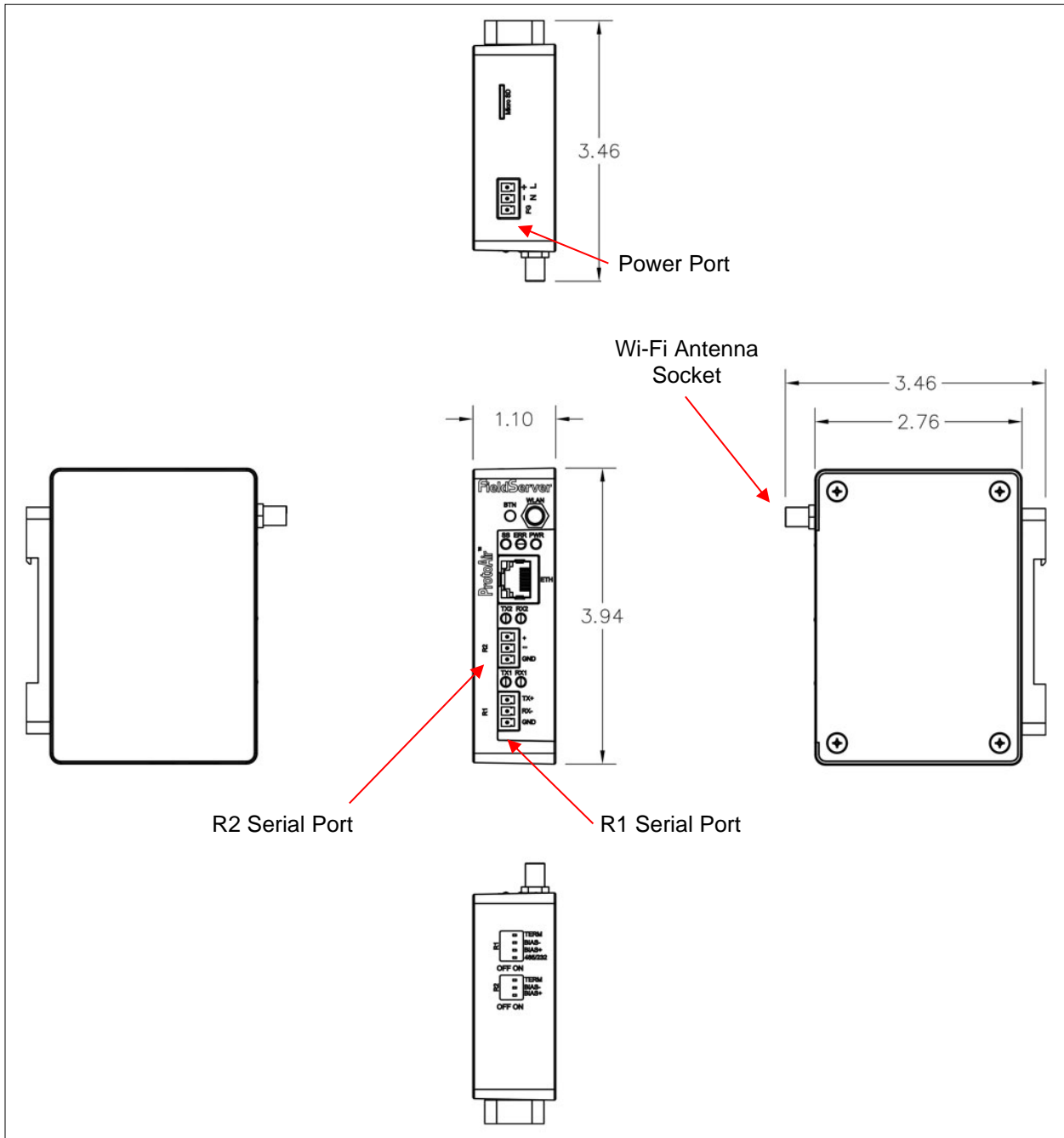

Figure 55: ProtoAir FPA-W44 Dimensions

Appendix C Vendor Information – Bosch

NOTE: All Modbus TCP/IP points are the same as the Modbus RTU points for the serial device. If this point list is needed, contact Bosch technical support. The Modbus TCP/IP node address of the device is also the same as the Modbus RTU node address.

Appendix C.1 C_Platform Modbus RTU Mappings to BACnet, Modbus TCP/IP and Metasys N2

Point Name	BACnet Object Type	BACnet Object ID	N2 Data Type	N2 Address
Unit Selection	AV	1	AO	1
Control Register	AV	2	AO	2
State	AI	3	AI	3
Status	AI	4	AI	4
Error Code	AI	5	AI	5
CH Pump	AI	6	AI	6
DHW Pump	AI	7	AI	7
General Pump	AI	8	AI	8
Supply Temperature	AI	9	AI	9
Return Temperature	AI	10	AI	10
DHW Temperature	AI	11	AI	11
Flue Gas Temperature	AI	12	AI	12
System (Heat Exchanger) Temperature	AI	13	AI	13
Outside Temperature	AI	14	AI	14
Firing Rate	AI	15	AI	15
Flame (Ionization) Current	AI	16	AI	16
Successful Ignition Counter	AI	18	AI	18
Failed Ignition Counter	AI	19	AI	19
Flame Failure Counter	AI	20	AI	20
Burn Hours CH	AI	21	AI	21
Burn Hours DHW	AI	22	AI	22
1st Lockout In History	AI	23	AI	23
2nd Lockout In History	AI	24	AI	24
3rd Lockout In History	AI	25	AI	25
4th Lockout In History	AI	26	AI	26
5th Lockout In History	AI	27	AI	27
6th Lockout In History	AI	28	AI	28
7th Lockout In History	AI	29	AI	29
8th Lockout In History	AI	30	AI	30
9th Lockout In History	AI	31	AI	31
10th Lockout In History	AI	32	AI	32
11th Lockout In History	AI	33	AI	33
12th Lockout In History	AI	34	AI	34
13th Lockout In History	AI	35	AI	35
14th Lockout In History	AI	36	AI	36
15th Lockout In History	AI	37	AI	37
16th Lockout In History	AI	38	AI	38
Time After 1st Lockout	AI	39	AI	39
Time After 2nd Lockout	AI	40	AI	40
Time After 3rd Lockout	AI	41	AI	41
Time After 4th Lockout	AI	42	AI	42
Time After 5th Lockout	AI	43	AI	43
Time After 6th Lockout	AI	44	AI	44
Time After 7th Lockout	AI	45	AI	45
Time After 8th Lockout	AI	46	AI	46
Time After 9th Lockout	AI	47	AI	47
Time After 10th Lockout	AI	48	AI	48
Time After 11th Lockout	AI	49	AI	49
Time After 12th Lockout	AI	50	AI	50
Time After 13th Lockout	AI	51	AI	51
Time After 14th Lockout	AI	52	AI	52
Time After 15th Lockout	AI	53	AI	53

Time After 16th Lockout	AI	54	AI	54
1st Blocking In History	AI	55	AI	55
2nd Blocking In History	AI	56	AI	56
3rd Blocking In History	AI	57	AI	57
4th Blocking In History	AI	58	AI	58
5th Blocking In History	AI	59	AI	59
6th Blocking In History	AI	60	AI	60
7th Blocking In History	AI	61	AI	61
8th Blocking In History	AI	62	AI	62
9th Blocking In History	AI	63	AI	63
10th Blocking In History	AI	64	AI	64
11th Blocking In History	AI	65	AI	65
12th Blocking In History	AI	66	AI	66
13th Blocking In History	AI	67	AI	67
14th Blocking In History	AI	68	AI	68
15th Blocking In History	AI	69	AI	69
16th Blocking In History	AI	70	AI	70
Time After 1st Blocking	AI	71	AI	71
Time After 2nd Blocking	AI	72	AI	72
Time After 3rd Blocking	AI	73	AI	73
Time After 4th Blocking	AI	74	AI	74
Time After 5th Blocking	AI	75	AI	75
Time After 6th Blocking	AI	76	AI	76
Time After 7th Blocking	AI	77	AI	77
Time After 8th Blocking	AI	78	AI	78
Time After 9th Blocking	AI	79	AI	79
Time After 10th Blocking	AI	80	AI	80
Time After 11th Blocking	AI	81	AI	81
Time After 12th Blocking	AI	82	AI	82
Time After 13th Blocking	AI	83	AI	83
Time After 14th Blocking	AI	84	AI	84
Time After 15th Blocking	AI	85	AI	85
Time After 16th Blocking	AI	86	AI	86
Dependent 01 State	AI	87	AI	87
Dependent 01 Error Code	AI	88	AI	88
Dependent 01 Firing Rate	AI	89	AI	89
Dependent 02 State	AI	90	AI	90
Dependent 02 Error Code	AI	91	AI	91
Dependent 02 Firing Rate	AI	92	AI	92
Dependent 03 State	AI	93	AI	93
Dependent 03 Error Code	AI	94	AI	94
Dependent 03 Firing Rate	AI	95	AI	95
Dependent 04 State	AI	96	AI	96
Dependent 04 Error Code	AI	97	AI	97
Dependent 04 Firing Rate	AI	98	AI	98
Dependent 05 State	AI	99	AI	99
Dependent 05 Error Code	AI	100	AI	100
Dependent 05 Firing Rate	AI	101	AI	101
Dependent 06 State	AI	102	AI	102
Dependent 06 Error Code	AI	103	AI	103
Dependent 06 Firing Rate	AI	104	AI	104
Dependent 07 State	AI	105	AI	105
Dependent 07 Error Code	AI	106	AI	106
Dependent 07 Firing Rate	AI	107	AI	107
Dependent 08 State	AI	108	AI	108
Dependent 08 Error Code	AI	109	AI	109
Dependent 08 Firing Rate	AI	110	AI	110
Dependent 09 State	AI	111	AI	111
Dependent 09 Error Code	AI	112	AI	112
Dependent 09 Firing Rate	AI	113	AI	113
Dependent 10 State	AI	114	AI	114
Dependent 10 Error Code	AI	115	AI	115
Dependent 10 Firing Rate	AI	116	AI	116
Dependent 11 State	AI	117	AI	117

Dependent 11 Error Code	AI	118	AI	118
Dependent 11 Firing Rate	AI	119	AI	119
Dependent 12 State	AI	120	AI	120
Dependent 12 Error Code	AI	121	AI	121
Dependent 12 Firing Rate	AI	122	AI	122
Dependent 13 State	AI	123	AI	123
Dependent 13 Error Code	AI	124	AI	124
Dependent 13 Firing Rate	AI	125	AI	125
Dependent 14 State	AI	126	AI	126
Dependent 14 Error Code	AI	127	AI	127
Dependent 14 Firing Rate	AI	128	AI	128
Dependent 15 State	AI	129	AI	129
Dependent 15 Error Code	AI	130	AI	130
Dependent 15 Firing Rate	AI	131	AI	131
CH Mode	AI	132	AI	132
DHW Mode	AI	133	AI	133
CH Setpoint	AI	134	AI	134
DHW Setpoint	AI	135	AI	135
Reset Curve Boiler Design	AI	136	AI	136
Reset Curve Boiler Mild Weather	AI	137	AI	137
Reset Curve Outdoor Mild Weather	AI	138	AI	138
Reset Curve Outdoor Design	AI	139	AI	139
Warm Weather Shutdown	AI	140	AI	140
Reset Curve Boiler Maximum	AI	141	AI	141
Reset Curve Boiler Minimum	AI	142	AI	142
Night Setback	AI	143	AI	143
CH Mode	AV	144	AO	144
DHW Mode	AV	145	AO	145
CH Setpoint	AV	146	AO	146
DHW Setpoint	AV	147	AO	147
Reset Curve Boiler Design	AV	148	AO	148
Reset Curve Boiler Mild Weather	AV	149	AO	149
Reset Curve Outdoor Mild Weather	AV	140	AO	140
Reset Curve Outdoor Design	AV	151	AO	151
Warm Weather Shutdown	AV	152	AO	152
Reset Curve Boiler Maximum	AV	153	AO	153
Reset Curve Boiler Minimum	AV	154	AO	154
Night Setback	AV	155	AO	155

Appendix C.2 D_Platform Modbus RTU Mappings to BACnet, Modbus TCP/IP and Metasys N2

Point Name	BACnet Object Type	BACnet Object ID	N2 Data Type	N2 Address
Sys_SP	AV	11	AI	11
Sys_OAT	AI	1	AI	1
Sys_Firing_Rate	AI	2	AI	2
Sys_SP	AI	3	AI	3
Sys_Temp	AI	4	AI	4
Sys_PmpSts	BI	1	DI	1
BLR1_Running	BI	5	DI	5
BLR1_Error	BI	6	DI	6
BLR1_Firing_Rate	AI	7	AI	7
BLR1_SP	AI	8	AI	8
BLR1_Supp_Temp	AI	9	AI	9
BLR1_Hours	AI	10	AI	10
BLR1mod1_State	AI	14	AI	14
BLR1mod1_ErrCode	AI	15	AI	15
BLR1mod1_Setpoint	AI	16	AI	16
BLR1mod1_FiringRate	AI	17	AI	17
BLR1mod1_WtrFlow	AI	18	AI	18

BLR1mod1_SuppTemp	AI	19	AI	19
BLR1mod1_RtrnTemp	AI	20	AI	20
BLR1mod1_FlueTemp	AI	21	AI	21
BLR1mod1_Hours	AI	22	AI	22
BLR1mod2_State	AI	23	AI	23
BLR1mod2_ErrCode	AI	24	AI	24
BLR1mod2_Setpoint	AI	25	AI	25
BLR1mod2_FiringRate	AI	26	AI	26
BLR1mod2_WtrFlow	AI	27	AI	27
BLR1mod2_SuppTemp	AI	28	AI	28
BLR1mod2_RtrnTemp	AI	29	AI	29
BLR1mod2_FlueTemp	AI	30	AI	30
BLR1mod2_Hours	AI	31	AI	31
BLR2_Running	BI	10	DI	10
BLR2_Error	BI	11	DI	11
BLR2_Firing_Rate	AI	107	AI	107
BLR2_SP	AI	108	AI	108
BLR2_Supp_Temp	AI	109	AI	109
BLR2_Hours	AI	110	AI	110
BLR2mod1_State	AI	114	AI	114
BLR2mod1_ErrCode	AI	115	AI	115
BLR2mod1_Setpoint	AI	116	AI	116
BLR2mod1_FiringRate	AI	117	AI	117
BLR2mod1_WtrFlow	AI	118	AI	118
BLR2mod1_SuppTemp	AI	119	AI	119
BLR2mod1_RtrnTemp	AI	120	AI	120
BLR2mod1_FlueTemp	AI	121	AI	121
BLR2mod1_Hours	AI	122	AI	122
BLR2mod2_State	AI	123	AI	123
BLR2mod2_ErrCode	AI	124	AI	124
BLR2mod2_Setpoint	AI	125	AI	125
BLR2mod2_FiringRate	AI	126	AI	126
BLR2mod2_WtrFlow	AI	127	AI	127
BLR2mod2_SuppTemp	AI	128	AI	128
BLR2mod2_RtrnTemp	AI	129	AI	129
BLR2mod2_FlueTemp	AI	130	AI	130
BLR2mod2_Hours	AI	131	AI	131
BLR3_Running	BI	15	DI	15
BLR3_Error	BI	16	DI	16
BLR3_Firing_Rate	AI	207	AI	207
BLR3_SP	AI	208	AI	208
BLR3_Supp_Temp	AI	209	AI	209
BLR3_Hours	AI	210	AI	210
BLR3mod1_State	AI	214	AI	214
BLR3mod1_ErrCode	AI	215	AI	215
BLR3mod1_Setpoint	AI	216	AI	216
BLR3mod1_FiringRate	AI	217	AI	217
BLR3mod1_WtrFlow	AI	218	AI	218
BLR3mod1_SuppTemp	AI	219	AI	219
BLR3mod1_RtrnTemp	AI	220	AI	220
BLR3mod1_FlueTemp	AI	221	AI	221
BLR3mod1_Hours	AI	222	AI	222
BLR3mod2_State	AI	223	AI	223
BLR3mod2_ErrCode	AI	224	AI	224
BLR3mod2_Setpoint	AI	225	AI	225
BLR3mod2_FiringRate	AI	226	AI	226
BLR3mod2_WtrFlow	AI	227	AI	227
BLR3mod2_SuppTemp	AI	228	AI	228
BLR3mod2_RtrnTemp	AI	229	AI	229
BLR3mod2_FlueTemp	AI	230	AI	230

BLR3mod2_Hours	AI	231	AI	231
BLR4_Running	BI	20	DI	20
BLR4_Error	BI	21	DI	21
BLR4_Firing_Rate	AI	307	ADI	30
BLR4_SP	AI	308	ADI	31
BLR4_Supp_Temp	AI	309	ADI	32
BLR4_Hours	AI	310	ADI	33
BLR4mod1_State	AI	314	ADI	34
BLR4mod1_ErrCode	AI	315	ADI	35
BLR4mod1_Setpoint	AI	316	ADI	36
BLR4mod1_FiringRate	AI	317	ADI	37
BLR4mod1_WtrFlow	AI	318	ADI	38
BLR4mod1_SuppTemp	AI	319	ADI	39
BLR4mod1_RtrnTemp	AI	320	ADI	40
BLR4mod1_FlueTemp	AI	321	ADI	41
BLR4mod1_Hours	AI	322	ADI	42
BLR4mod2_State	AI	323	ADI	43
BLR4mod2_ErrCode	AI	324	ADI	44
BLR4mod2_Setpoint	AI	325	ADI	45
BLR4mod2_FiringRate	AI	326	ADI	46
BLR4mod2_WtrFlow	AI	327	ADI	47
BLR4mod2_SuppTemp	AI	328	ADI	48
BLR4mod2_RtrnTemp	AI	329	ADI	49
BLR4mod2_FlueTemp	AI	330	ADI	50
BLR4mod2_Hours	AI	331	ADI	51
BLR5_Running	BI	405	DI	22
BLR5_Error	BI	406	DI	23
BLR5_Firing_Rate	AI	407	ADI	106
BLR5_SP	AI	408	ADI	107
BLR5_Supp_Temp	AI	409	ADI	108
BLR5_Hours	AI	410	ADI	109
BLR5mod1_State	AI	414	ADF	152
BLR5mod1_ErrCode	AI	415	ADF	153
BLR5mod1_Setpoint	AI	416	ADI	110
BLR5mod1_FiringRate	AI	417	ADI	111
BLR5mod1_WtrFlow	AI	418	ADI	112
BLR5mod1_SuppTemp	AI	419	ADI	113
BLR5mod1_RtrnTemp	AI	420	ADI	114
BLR5mod1_FlueTemp	AI	421	ADI	115
BLR5mod1_Hours	AI	422	ADI	116
BLR5mod2_State	AI	423	ADI	117
BLR5mod2_ErrCode	AI	424	ADI	118
BLR5mod2_Setpoint	AI	425	ADI	119
BLR5mod2_FiringRate	AI	426	ADI	120
BLR5mod2_WtrFlow	AI	427	ADI	121
BLR5mod2_SuppTemp	AI	428	ADI	122
BLR5mod2_RtrnTemp	AI	429	ADI	123
BLR5mod2_FlueTemp	AI	430	ADI	124
BLR5mod2_Hours	AI	431	ADI	125
BLR6_Running	BI	30	DI	30
BLR6_Error	BI	31	DI	31
BLR6_Firing_Rate	AI	507	ADI	180
BLR6_SP	AI	508	ADI	181
BLR6_Supp_Temp	AI	509	ADI	182
BLR6_Hours	AI	510	ADI	183
BLR6mod1_State	AI	514	ADI	184
BLR6mod1_ErrCode	AI	515	ADI	185
BLR6mod1_Setpoint	AI	516	ADI	186

BLR6mod1_FiringRate	AI	517	ADI	187
BLR6mod1_WtrFlow	AI	518	ADI	188
BLR6mod1_SuppTemp	AI	519	ADI	189
BLR6mod1_RtrnTemp	AI	520	ADI	190
BLR6mod1_FlueTemp	AI	521	ADI	191
BLR6mod1_Hours	AI	522	ADI	192
BLR6mod2_State	AI	523	ADI	193
BLR6mod2_ErrCode	AI	524	ADI	194
BLR6mod2_Setpoint	AI	525	ADI	195
BLR6mod2_FiringRate	AI	526	ADI	196
BLR6mod2_WtrFlow	AI	527	ADI	197
BLR6mod2_SuppTemp	AI	528	ADI	198
BLR6mod2_RtrnTemp	AI	529	ADI	199
BLR6mod2_FlueTemp	AI	530	ADI	200
BLR6mod2_Hours	AI	531	ADI	201
BLR7_Running	BI	35	DI	35
BLR7Error	BI	36	DI	36
BLR7_Firing_Rate	AI	607	ADI	256
BLR7_SP	AI	608	ADF	1
BLR7_Supp_Temp	AI	609	ADF	2
BLR7_Hours	AI	610	ADF	3
BLR7mod1_State	AI	614	ADF	4
BLR7mod1_ErrCode	AI	615	ADF	5
BLR7mod1_Setpoint	AI	616	ADF	6
BLR7mod1_FiringRate	AI	617	ADF	7
BLR7mod1_WtrFlow	AI	618	ADF	8
BLR7mod1_SuppTemp	AI	619	ADF	9
BLR7mod1_RtrnTemp	AI	620	ADF	10
BLR7mod1_FlueTemp	AI	621	ADF	11
BLR7mod1_Hours	AI	622	ADF	12
BLR7mod2_State	AI	623	ADF	13
BLR7mod2_ErrCode	AI	624	ADF	14
BLR7mod2_Setpoint	AI	625	ADF	15
BLR7mod2_FiringRate	AI	626	ADF	16
BLR7mod2_WtrFlow	AI	627	ADF	17
BLR7mod2_SuppTemp	AI	628	ADF	18
BLR7mod2_RtrnTemp	AI	629	ADF	19
BLR7mod2_FlueTemp	AI	630	ADF	20
BLR7mod2_Hours	AI	631	ADF	21
BLR8_Running	BI	40	DI	40
BLR8_Error	BI	41	DI	41
BLR8_Firing_Rate	AI	707	ADF	76
BLR8_SP	AI	708	ADF	77
BLR8_Supp_Temp	AI	709	ADF	78
BLR8_Hours	AI	710	ADF	79
BLR8mod1_State	AI	714	ADF	80
BLR8mod1_ErrCode	AI	715	ADF	81
BLR8mod1_Setpoint	AI	716	ADF	82
BLR8mod1_FiringRate	AI	717	ADF	83
BLR8od1_WtrFlow	AI	718	ADF	84
BLR8mod1_SuppTemp	AI	719	ADF	85
BLR8mod1_RtrnTemp	AI	720	ADF	86
BLR8mod1_FlueTemp	AI	721	ADF	87
BLR8mod1_Hours	AI	722	ADF	88
BLR8mod2_State	AI	723	ADF	89
BLR8mod2_ErrCode	AI	724	ADF	90
BLR8mod2_Setpoint	AI	725	ADF	91
BLR8mod2_FiringRate	AI	726	ADF	92
BLR8mod2_WtrFlow	AI	727	ADF	93
BLR8mod2_SuppTemp	AI	728	ADF	94

BLR8mod2_RtrnTemp	AI	729	ADF	95
BLR8mod2_FlueTemp	AI	730	ADF	96
BLR8mod2_Hours	AI	731	ADF	97

Appendix E Limited 2 Year Warranty

MSA Safety warrants its products to be free from defects in workmanship or material under normal use and service for two years after date of shipment. MSA Safety will repair or replace any equipment found to be defective during the warranty period. Final determination of the nature and responsibility for defective or damaged equipment will be made by MSA Safety personnel.

All warranties hereunder are contingent upon proper use in the application for which the product was intended and do not cover products which have been modified or repaired without MSA Safety's approval or which have been subjected to accident, improper maintenance, installation or application, or on which original identification marks have been removed or altered. This Limited Warranty also will not apply to interconnecting cables or wires, consumables or to any damage resulting from battery leakage.

In all cases MSA Safety's responsibility and liability under this warranty shall be limited to the cost of the equipment. The purchaser must obtain shipping instructions for the prepaid return of any item under this warranty provision and compliance with such instruction shall be a condition of this warranty.

Except for the express warranty stated above, MSA Safety disclaims all warranties with regard to the products sold hereunder including all implied warranties of merchantability and fitness and the express warranties stated herein are in lieu of all obligations or liabilities on the part of MSA Safety for damages including, but not limited to, consequential damages arising out of/or in connection with the use or performance of the product.