

KBR-3

120-280 kW

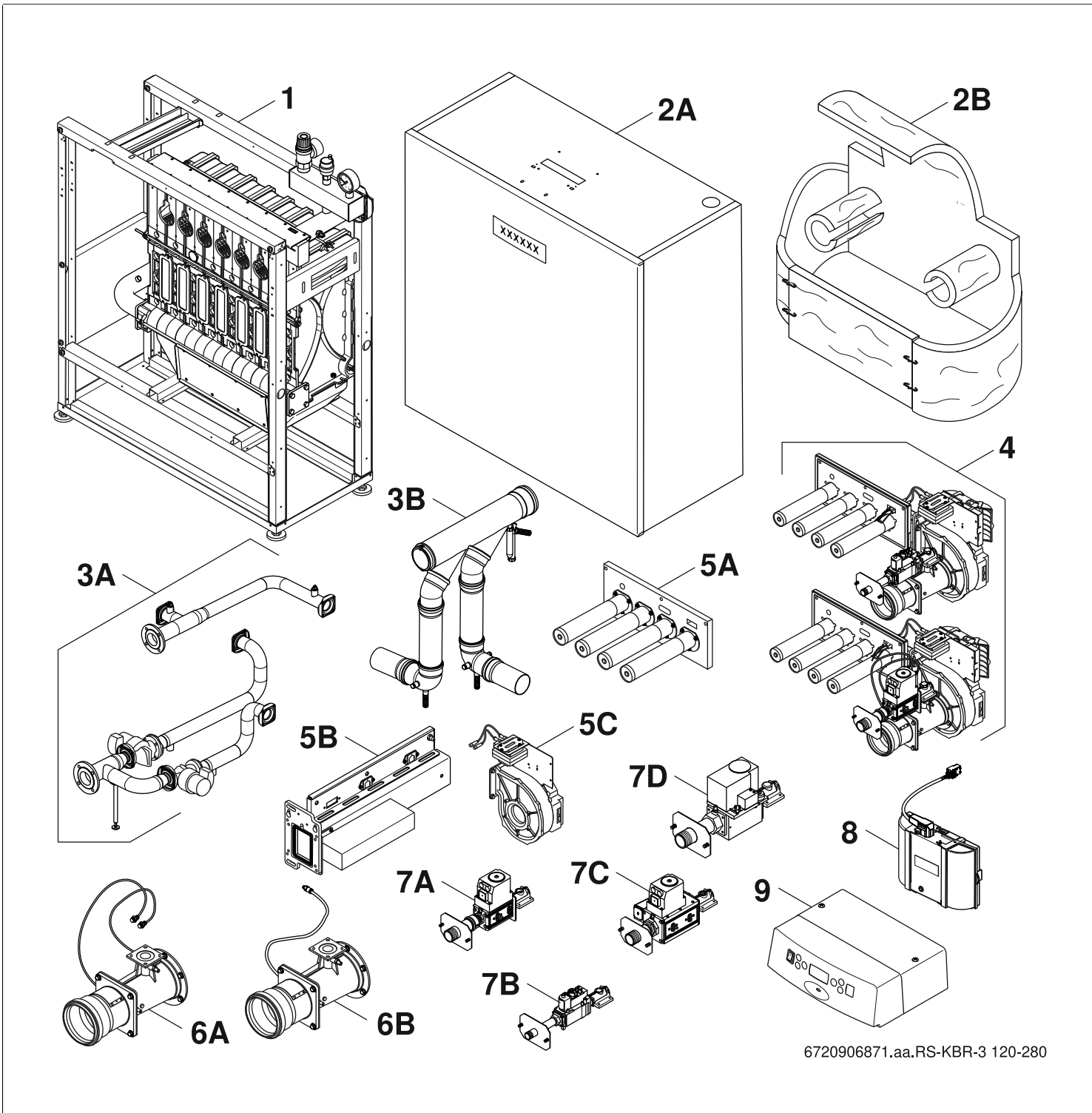

6720906871.aa.RS-KBR-3 120-280

[de] Wichtige Hinweise zur Installation/Montage

Die Installation/Montage muss durch eine für die Arbeiten zugelassene Fachkraft unter Beachtung der geltenden Vorschriften erfolgen.

[en] Important notes on installation/assembly

The installation/assembly must be carried out by a qualified contractor, following these instructions and in compliance with the applicable regulations.

[fr] Instructions importantes pour l'installation/le montage

L'installation/le montage doit être effectué(e) par un spécialiste qualifié pour les opérations concernées et dans le respect de la présente notice et des prescriptions applicables.

[bg] Важни указания във връзка с инсталацията/монтажа

Инсталацията/монтажът трябва да се извършва от лицензиран за работите специалист в съответствие с настоящото ръководство и с приложените разпоредби.

[cs] Důležité pokyny k instalaci/montáži

Instalaci/montáž musí při dodržení pokynů uvedených v tomto návodu a platných předpisů provést odborný pracovník s příslušným oprávněním pro tyto práce.

[da] Vigtige anvisninger til installationen/monteringen

Installationen/monteringen skal foretages af en godkendt installatør under overholdelse af denne vejledning og de gældende forskrifter.

[el] Σημαντικές υποδείξεις για την εγκατάσταση/συναρμολόγηση

Η εγκατάσταση/τοποθέτηση πρέπει να ανατίθεται σε εκπαιδευμένο για τις συγκεκριμένες εργασίες τεχνικό προσωπικό με τήρηση αυτών των οδηγιών καθώς και των σχετικών προδιαγραφών.

[es] Indicaciones importantes para instalación/montaje

La instalación/el montaje debe realizarla personal especializado que esté autorizado para realizar estos trabajos y que tenga en cuenta estas instrucciones y la normativa vigente.

[et] Olulised juhised paigaldamiseks/montaažiks

Paigaldamist/montaaži tohib läbi viia vaid selleks volitusi omav spetsialist, arvestades kehtivaid nõudeid.

[nl-BE] Belangrijke aanwijzingen betreffende de installatie/montage

De installatie/montage moet worden uitgevoerd door een voor de werkzaamheden geautoriseerde installateur rekening houdend met deze handleiding en de geldende voorschriften.

[fi] Tärkeitä asennus- ja kokoonpano-ohjeita

Näihin töihin hyväksytyt ammattiasentajan pitää suorittaa asennus- ja kokoonpanotyöt voimassa olevien määräysten mukaisesti.

[hu] Fontos tudnivalók az installálás/szereléshez

A telepítést/szerelést egy, a munkálatokra felhatalmazott szakembernek kell végeznie, jelen utasítás és az érvényes előírások figyelembevételével.

[it] Avvertenze importanti per l'installazione/il montaggio

L'installazione/il montaggio deve aver luogo ad opera di una ditta specializzata ed autorizzata in osservanza di queste istruzioni e delle direttive vigenti.

[ka] მნიშვნელოვანი მითითებები ინსტალაციისთვის/მონტაჟისთვის

ინსტალაცია/მონტაჟი უნდა განხორციელდეს სამუშაოებისთვის დაშვებული კვალიფიციური პერსონალის მიერ, მოქმედი განაცხადის დაცვით.

[it] Svarbios instaliavimo ir (arba) montavimo nuorodos

Instaliavimo/montavimo darbus, laikydamiesi šios instrukcijos reikalavimų ir galiojančių taisyklių, privalo atlikti šiems darbams įgalioti specialistai.

[sq] Shënime të rëndësishme për instalimin/montimin

Instalimi/montimi duhet të bëhet nga një kontraktues i kualifikuar, duke ndjekur këto udhëzime dhe në përputhje me rregulloret në fuqi.

[lv] Svarīgi norādījumi par iekārtas uzstādīšanu / montāžu

Uzstādīšanu/montāžu jāveic atbilstošajiem darbiem sertificētam speciālistam, ievērojot šo instrukciju un spēkā esošos noteikumus.

[nl] Belangrijke aanwijzingen betreffende de installatie/montage

De installatie/montage moet door een erkend installateur volgens de geldende voorschriften worden uitgevoerd.

[no] Viktig informasjon om installasjon/montering

Installasjonen/monteringen skal gjennomføres av autoriserte installatører, og installasjonsanvisningen samt gjeldende forskrifter skal følges.

[pl] Ważne wskazówki dotyczące instalacji/montażu

Instalację/montaż powinien wykonać specjalista uprawniony do tego typu prac z uwzględnieniem informacji podanych w niniejszej instrukcji oraz aktualnie obowiązujących przepisów.

[pt] Indicações importantes relativas à instalação/montagem

A instalação/montagem deve ser efectuada por um técnico autorizado para os trabalhos, respeitando este manual e as prescrições válidas.

[ro] Indicații importante privind instalarea/montajul

Instalarea/montajul trebuie realizate de către un specialist autorizat pentru lucrările respective, respectându-se prezentele instrucțiuni și prescripțiile valabile.

[ru] Важные указания по подключению/монтажу

Подключение/монтаж должны выполнять только специалисты, имеющие допуск к выполнению таких работ, при соблюдении требований этой инструкции и действующих норм и правил.

[sk] Dôležité pokyny týkajúce sa inštalácie/montáže

Inštaláciu/montáž musí vykonať odborný personál, ktorý má oprávnenie pre výkon týchto prác, pričom musí dodržiavať pokyny uvedené v tomto návode a platné predpisy.

[sl] Pomembni napotki za namestitvev/montažo

Inštalacijo/montažo lahko izvede samo pooblaščen strokovnjak ob upoštevanju teh navodil in veljavnih predpisov.

[sr] Važna uputstva za ugradnju i montažu

Ovu instalaciju/montažu moraju da obave stručna lica koja su ovlašćena za obavljanje takvih radova u skladu sa ovim uputstvom i važećim propisima.

[sv] Viktiga anvisningar för installation/montering

Installationen/monteringen måste utföras av en behörig och tekniskt utbildad person enligt denna anvisning samt gällande föreskrifter.

[tr] Kurulum/Montaj ile ilgili önemli uyarılar

Kurulum/montaj, bu çalışmalarını yapmasına müsaade edilen uzman kişiler tarafından işbu kılavuz ve geçerli yönetmelikler dikkate alınarak yapılmalıdır.

[uk] Важливі вказівки щодо установки/монтажу

Встановлення/монтаж повинні виконувати фахівці, що допущені до виконання таких робіт, із дотриманням цієї інструкції та діючих приписів.

[zh] 安装方面的重要提示

安装和组装工作必须由经过许可的专业人员进行，同时必须遵守本说明书和现行法规的相关要求

[ar] ملاحظات هامة للتثبيت/التجميع
يجب أن يتم التثبيت/التجميع من قبل متخصص مصرح له بالعمل، مع مراعاة اللوائح السارية.

[fa] تذکرات مهم درباره نصب/مونتاژ
نصب/مونتاژ باید توسط فردی حرفه ای که مجاز به انجام این کار است، و همچنین با توجه کامل به مقررات مربوطه انجام شود.

[az] Quraşdırılma

Quraşdırılma işinin yerinə yetirilməsi səlahiyyətli bir mütəxəssis tərəfindən və müvafiq qaydalara uyğun olaraq aparılmalıdır.

Ersatzteilliste
Spare parts list

Liste des pièces de rechange
Lista parti di ricambio

Onderdelenlijst
Lista de repuestos

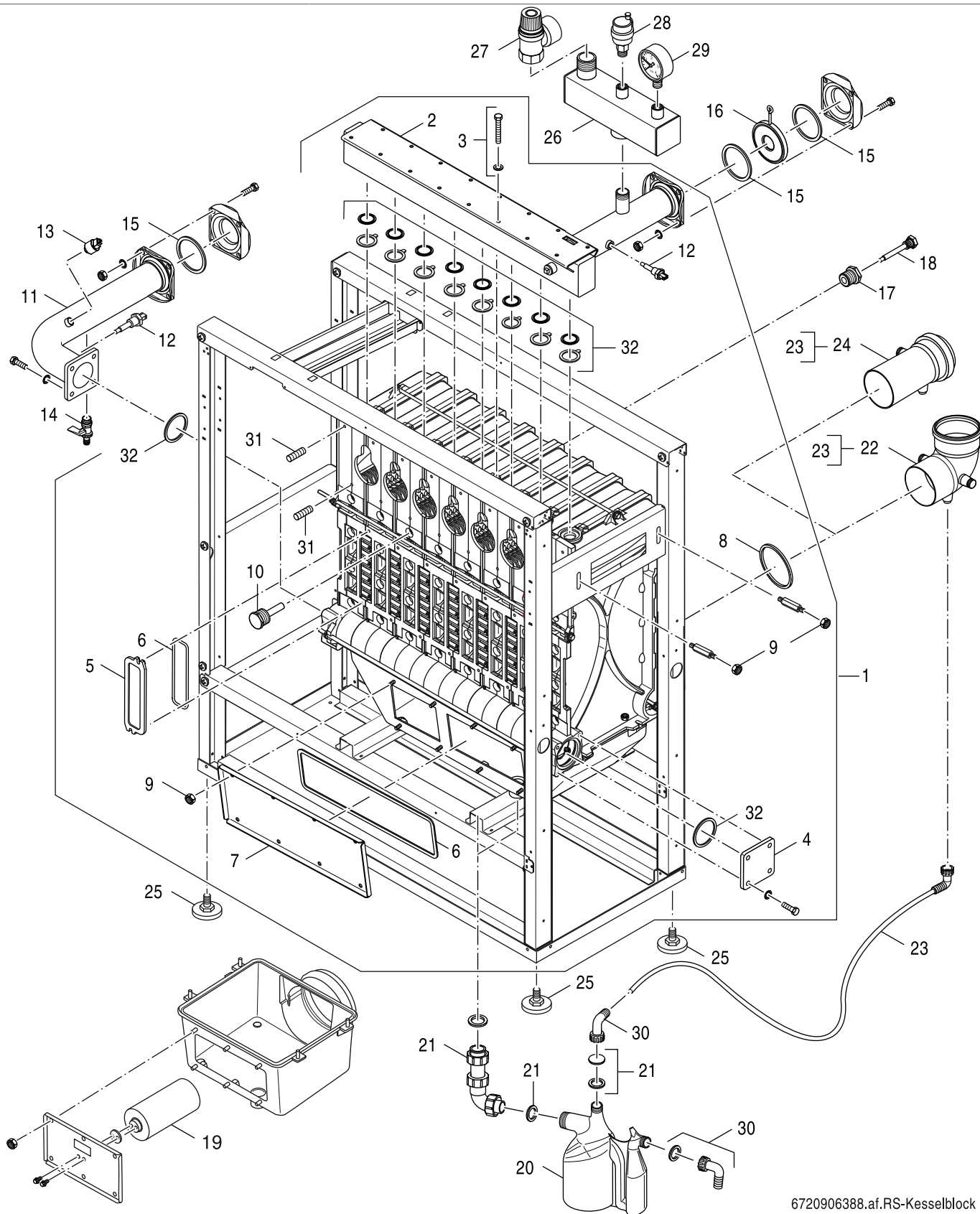

6720906388.af.RS-Kesselblock

1

Kesselblock
Boiler block
Bloc chaudière
Corpo caldaia
Ketelblok
Cuerpo de caldera

KBR-3
120-280 kW

Ersatzteilliste
Spare parts list

Liste des pièces de rechange
Lista parti di ricambio

Onderdelenlijst
Lista de repuestos

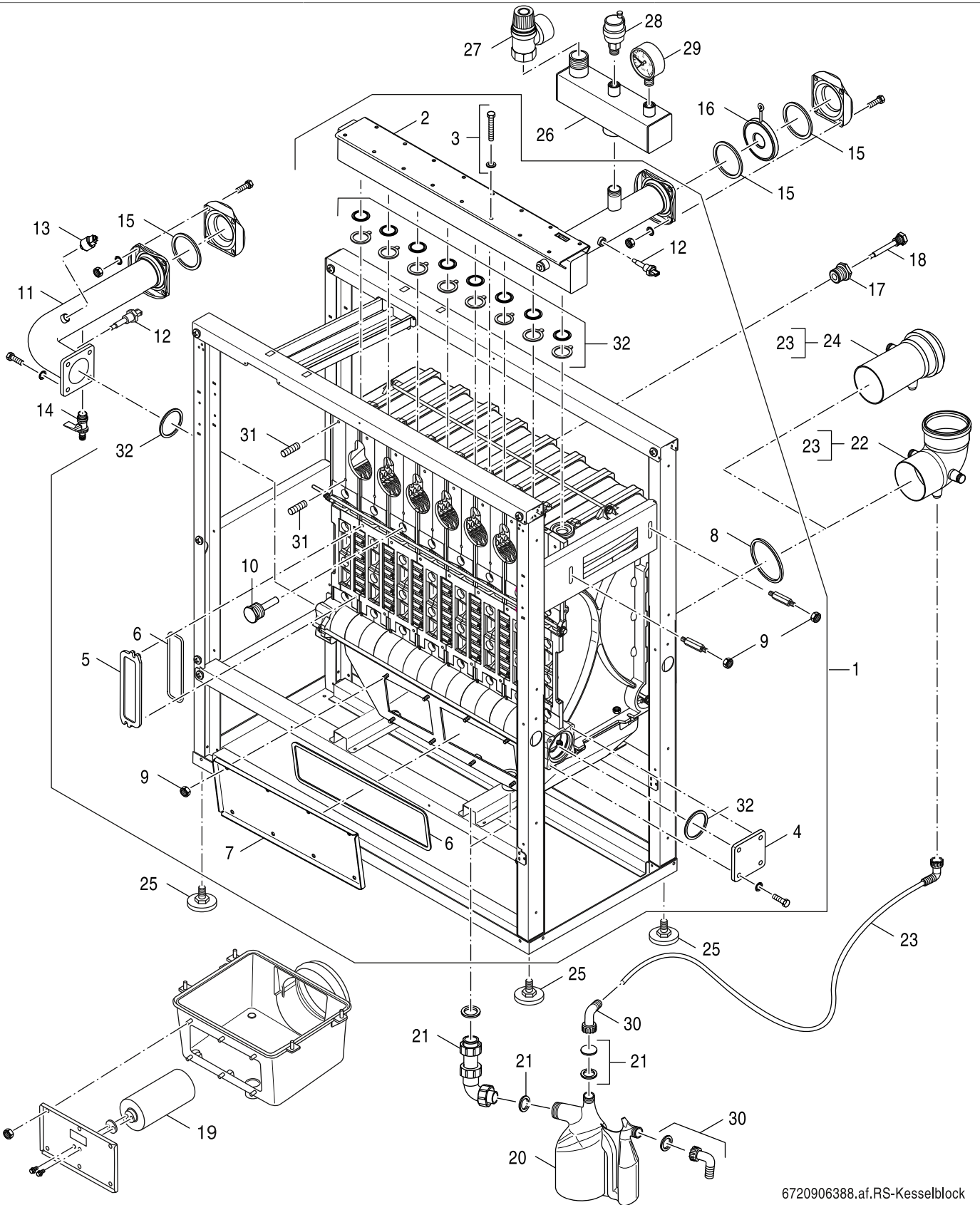

6720906388.af.RS-Kesselblock

1

Kesselblock
Boiler block
Bloc chaudière
Corpo caldaia
Ketelblok
Cuerpo de caldera

KBR-3
120-280 kW

Pos	Bezeichnung Description Dénomination Descrizioni Benaming Descripción		KBR-3 120 A21	KBR-3 120 A23	KBR-3 160 A21	KBR-3 160 A23	KBR-3 200 A21	KBR-3 200 A23	KBR-3 240 A21	KBR-3 240 A23	KBR-3 280 A21	KBR-3 280 A23							Bemerkungen Remarks Remarques Osservazioni Opmerkingen Observaciones
30	Schlauchtülle G3/4x20 gewinkelt everp	8 738 803 123	■	■	■	■	■	■	■	■	■	■							
31	Stiftschr. DIN939 M8x35 5,6 everp (4x)	8 718 584 607	■	■	■	■	■	■	■	■	■	■							
32	Dichtungssatz Kesselblock GB312 everp	6 303 729 1	■	■	■	■	■	■	■	■	■	■							
	Mont-Mat Druckausdf V2 everp	6 302 850 7	■	■	■	■	■	■	■	■	■	■							
	Silikon Wezilil EV-300 rot 300°C everp	8 718 590 462	■	■	■	■	■	■	■	■	■	■							

KBR-3 120-280 kW	Kesselblock Boiler block Bloc chaudière Corpo caldaia Ketelblok Cuerpo de caldera	1
-----------------------------------	--	----------

Ersatzteilliste
Spare parts list

Liste des pièces de rechange
Lista parti di ricambio

Onderdelenlijst
Lista de repuestos

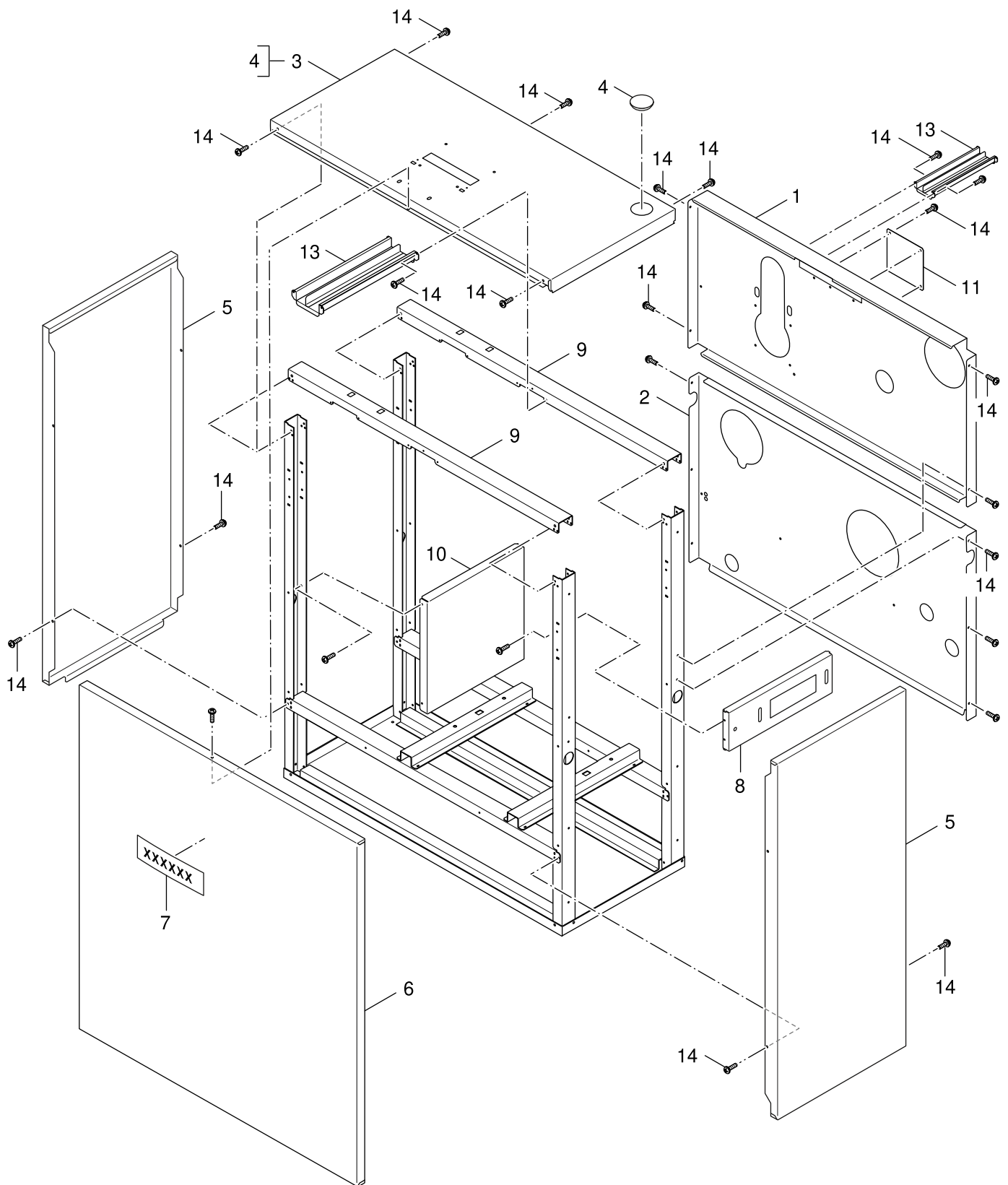

8738890143.aa.RS-Verkleidung KBR-3 120-180kW

2A
Verkleidung
Housing
Carénage
Rivestimento
Bekleding
Revestimiento

KBR-3
120-280 kW

Ersatzteilliste
Spare parts list

Liste des pièces de rechange
Lista parti di ricambio

Onderdelenlijst
Lista de repuestos

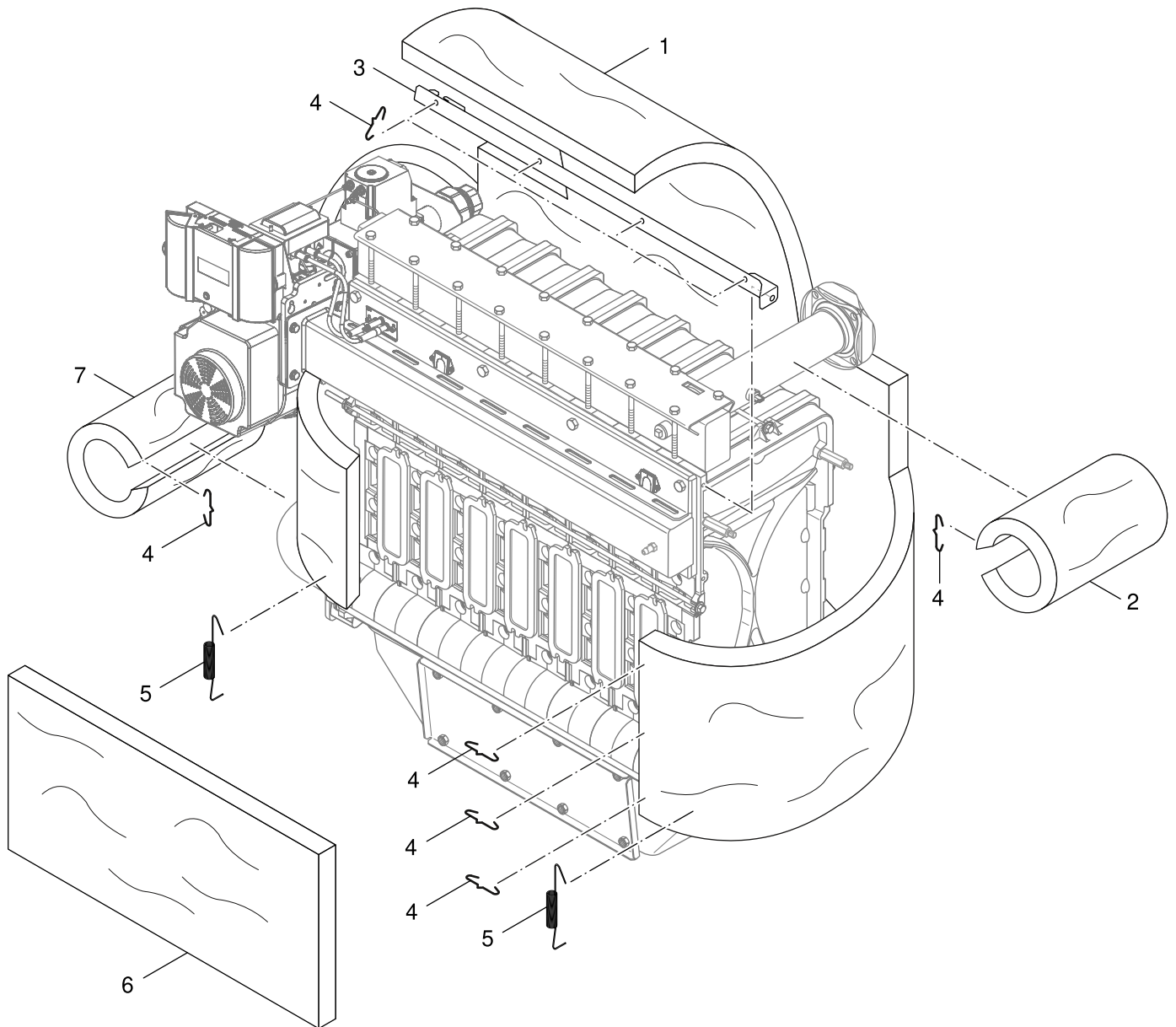

6720906390.aa.RS-Wärmeschutz

2B
Wärmeschutz
Heat insulation
Thermiqueprotection
Termicoprotezione
Warmtebescherming
Aislamiento térmico

KBR-3
120-280 kW

Ersatzteilliste
Spare parts list

Liste des pièces de rechange
Lista parti di ricambio

Onderdelenlijst
Lista de repuestos

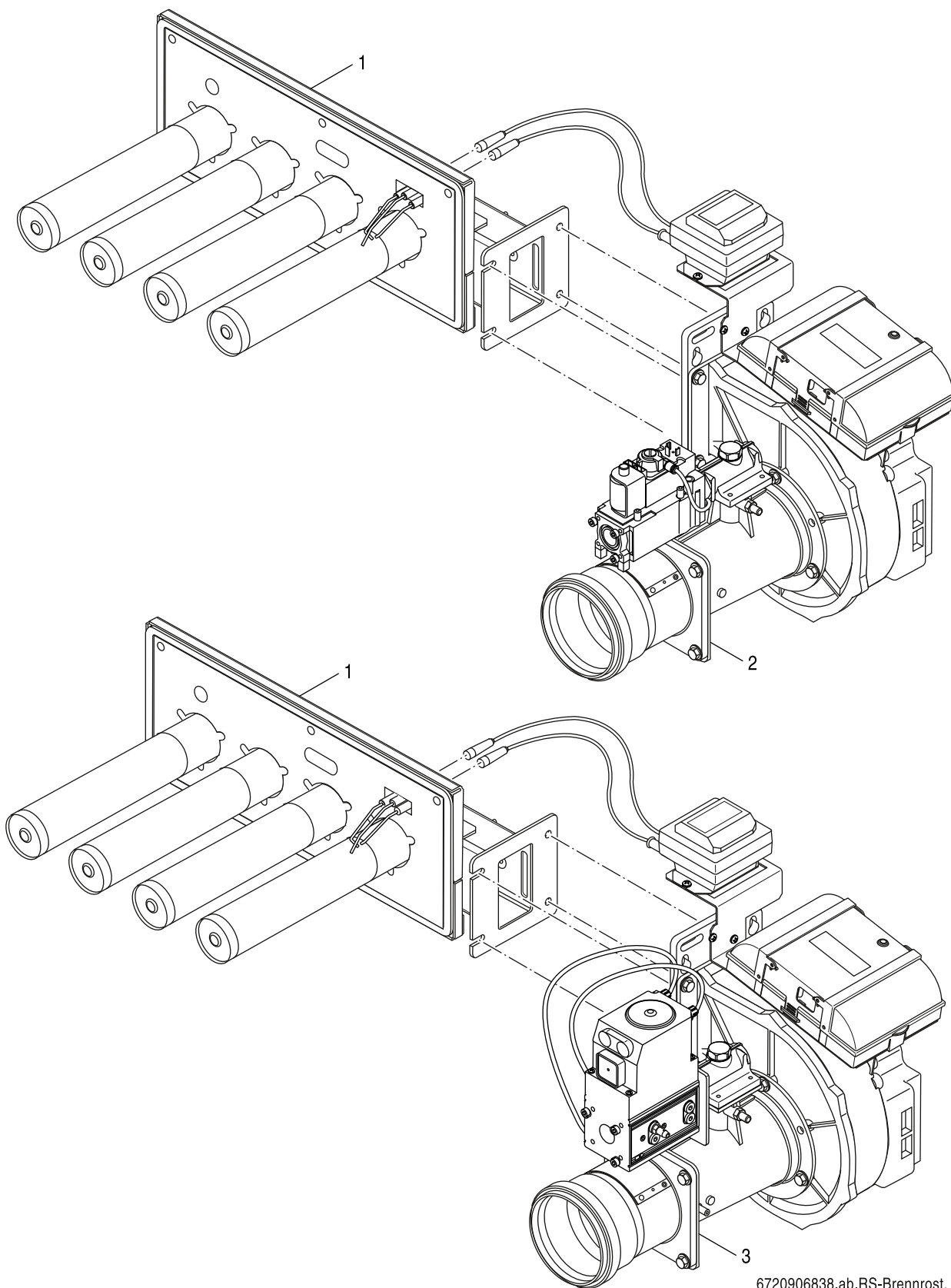

6720906838.ab.RS-Brennrost, Gebl seeinheit

4

Brennrost, Gebläseeinheit GB312
Burner grate, Fan GB312
Grille de combustion, Ventilateur GB312
Griglia, Ventilatore GB312
Branderrooster, Ventilator GB312
Óxido de combustión, Ventilador GB312

KBR-3
120-280 kW

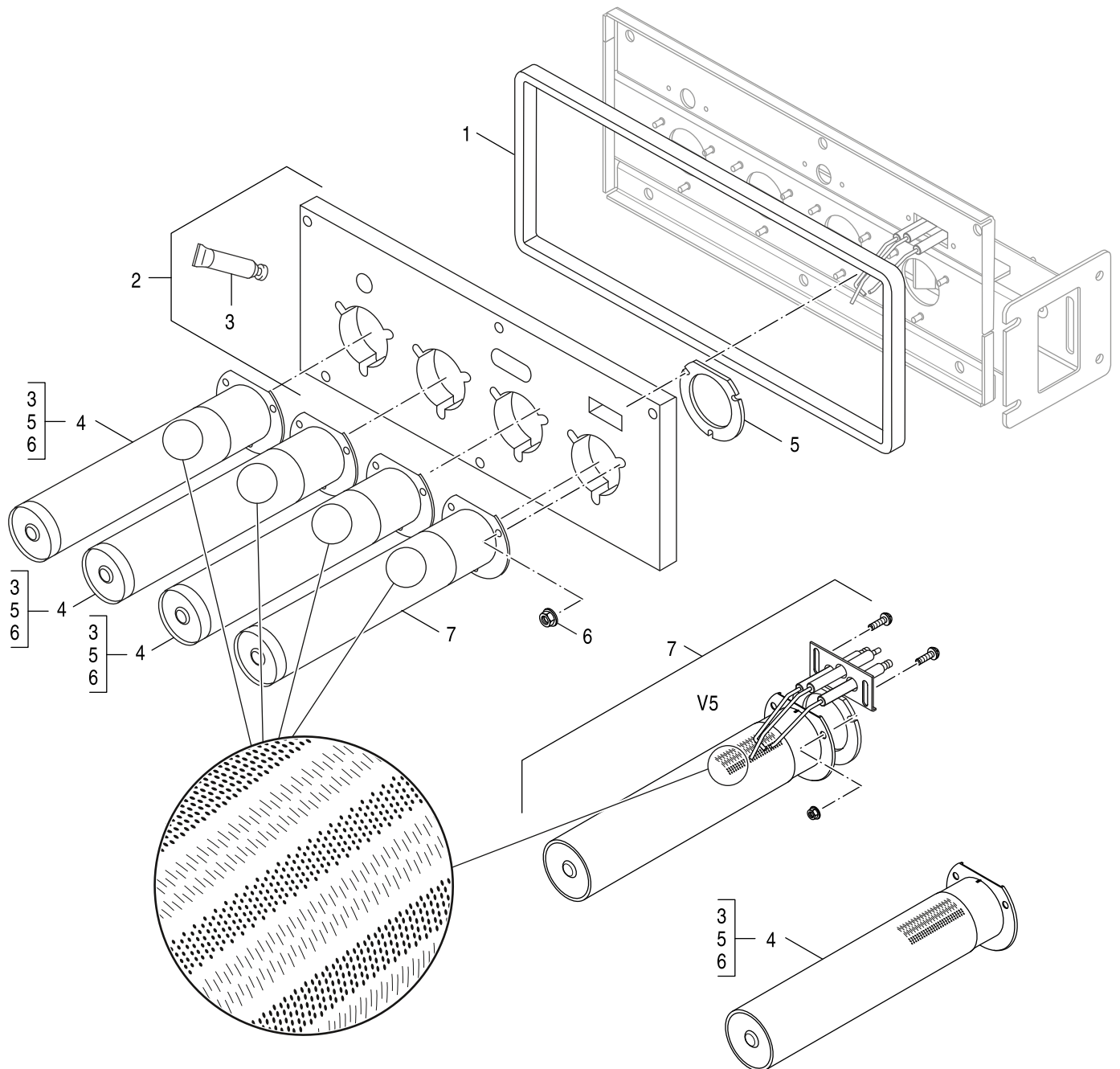

6720906393.ac.RS-Brennstab

5A
Brennstab
Burner rod
Rampe de combustion
Torcia del bruciatore
Staafterander
Barra combustible

KBR-3
120-280 kW

Pos	Bezeichnung Description Dénomination Descrizioni Benaming Descripción		KBR-3 120 A21	KBR-3 120 A23	KBR-3 160 A21	KBR-3 160 A23	KBR-3 200 A21	KBR-3 200 A23	KBR-3 240 A21	KBR-3 240 A23	KBR-3 280 A21	KBR-3 280 A23							Bemerkungen Remarks Remarques Osservazioni Opmerkingen Observaciones
1	Dichtprofil 120 everp	8 718 598 182	■	■															
1	Dichtprofil 160 everp	8 718 598 183			■	■													
1	Dichtprofil 200 everp	8 718 598 184					■	■											
1	Dichtprofil 240 everp	8 718 598 185							■	■									
1	Dichtprofil 280 everp	8 718 598 186									■	■							
2	Wärmeschutz 120	6 303 610 7	■	■															
2	Wärmeschutz 160	6 303 610 8			■	■													
2	Wärmeschutz 200	6 303 610 9					■	■											
2	Wärmeschutz 240	6 303 611 0							■	■									
2	Wärmeschutz 280	6 303 611 1									■	■							
3	Keramikleber 115gr Tube everp	8 718 576 016 0	■	■	■	■	■	■	■	■	■	■							
4	Brennstab V5 everp	7 736 616 427	■	■	■	■	■	■	■	■	■	■							
5	Dichtung Brennstab everp	6 303 611 9	■	■	■	■	■	■	■	■	■	■							
6	6kt-Mutter EN1661 M5 10 A3K Sperrverz ev	8 718 584 465	■	■	■	■	■	■	■	■	■	■							
7	Zündset VM312 V5	8 718 593 669	■	■	■	■	■	■	■	■	■	■							

**KBR-3
120-280 kW**

Brennstab
Burner rod
Rampe de combustion
Torcia del bruciatore
Staafterander
Barra combustible

5A

Ersatzteilliste
Spare parts list

Liste des pièces de rechange
Lista parti di ricambio

Onderdelenlijst
Lista de repuestos

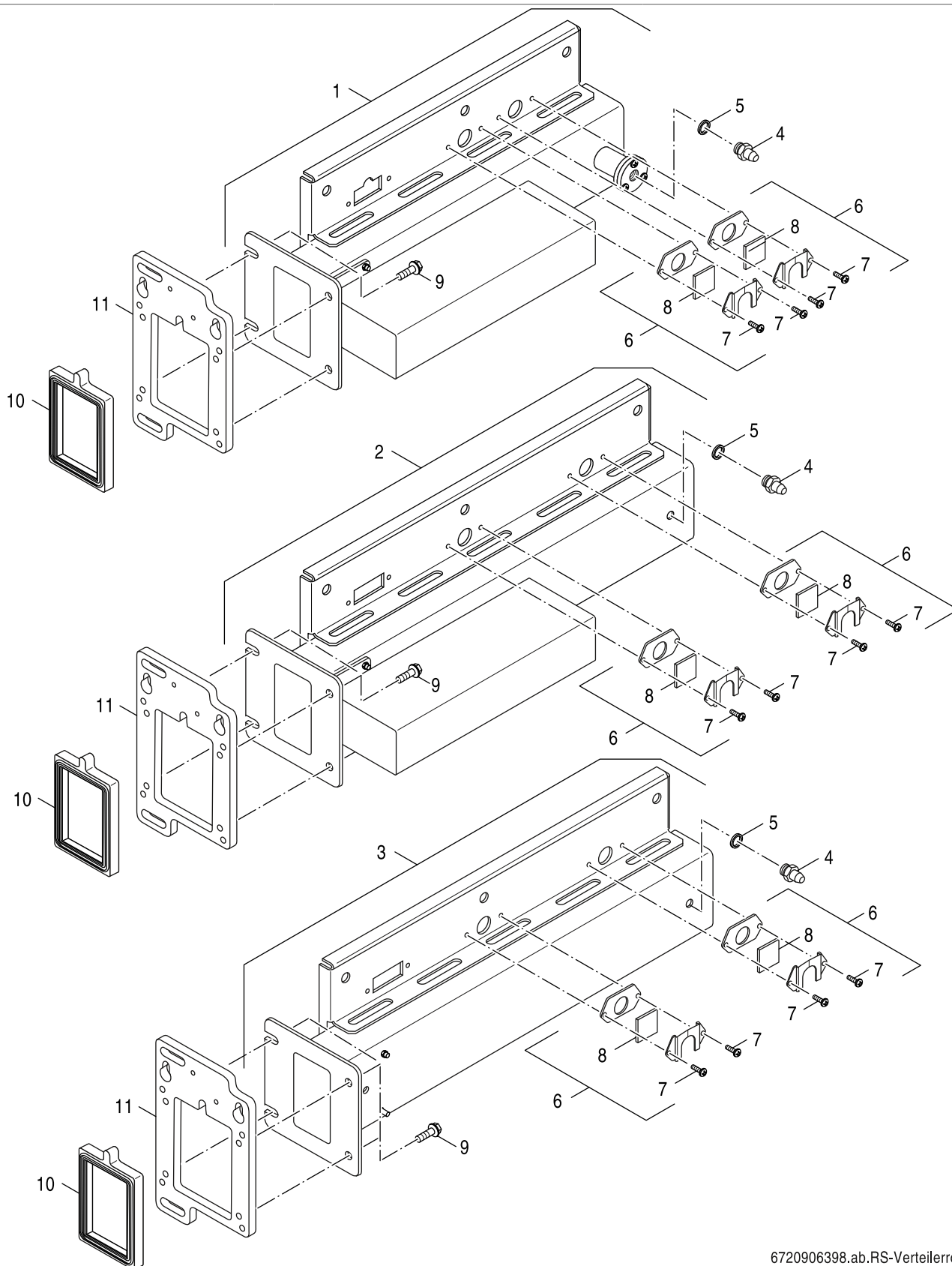

6720906398.ab.RS-Verteilerrohr

5B

Verteilerrohr
Tube distributor
Rampe injecteur
Tubo di distribuzione
Verdeelbuis
Tubo distribución

KBR-3
120-280 kW

Ersatzteilliste
Spare parts list

Liste des pièces de rechange
Lista parti di ricambio

Onderdelenlijst
Lista de repuestos

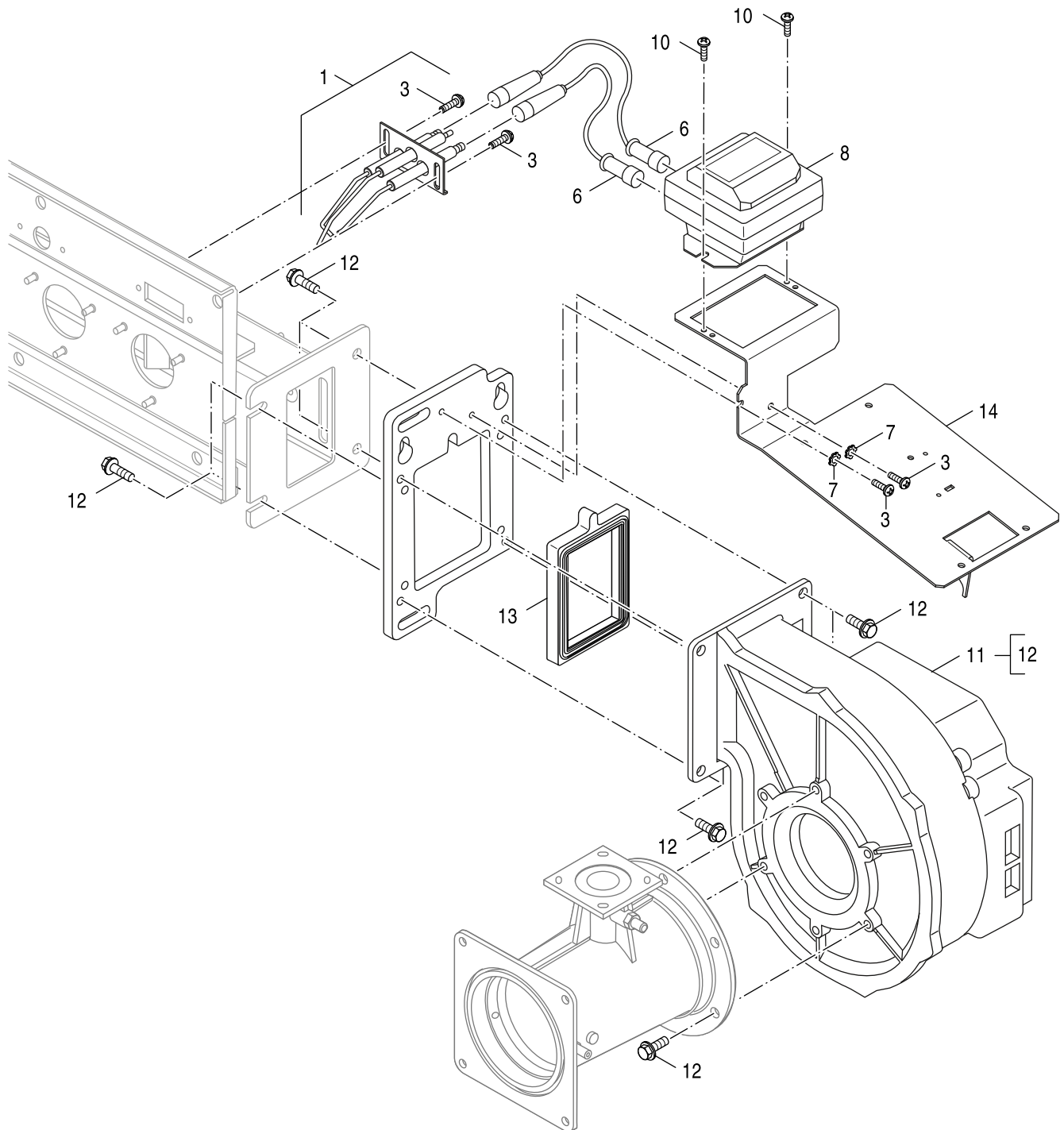

6720906841.aa.RS-Z ündeinrichtung

5C
Zünderinrichtung
ignition device
dispositif d'allumage
dispositivo di accensione
ontstekingsunit
dispositivo de encendido

KBR-3
120-280 kW

Ersatzteilliste
Spare parts list

Liste des pièces de rechange
Lista parti di ricambio

Onderdelenlijst
Lista de repuestos

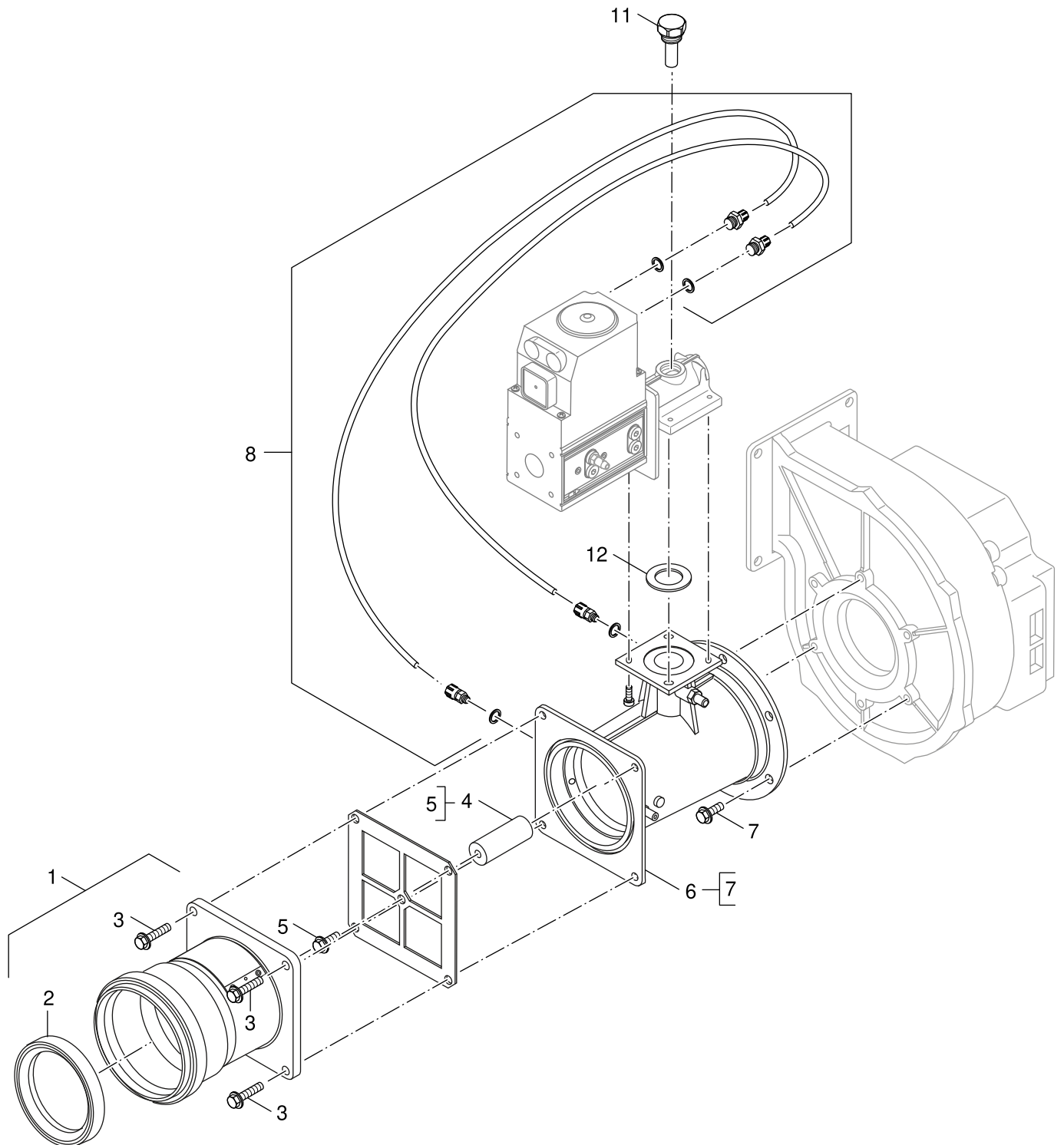

6720906400.aa.RS-Verbrennungsluftzufuhr CG

6A
Verbrennungsluftzufuhr CG
Combustion air supply CG
Alimentation en air de combustion
Adduzione dell'aria comburente
Verbrandingsluchttoevoer
Entrada de aire de combustión

KBR-3
120-280 kW

Ersatzteilliste
Spare parts list

Liste des pièces de rechange
Lista parti di ricambio

Onderdelenlijst
Lista de repuestos

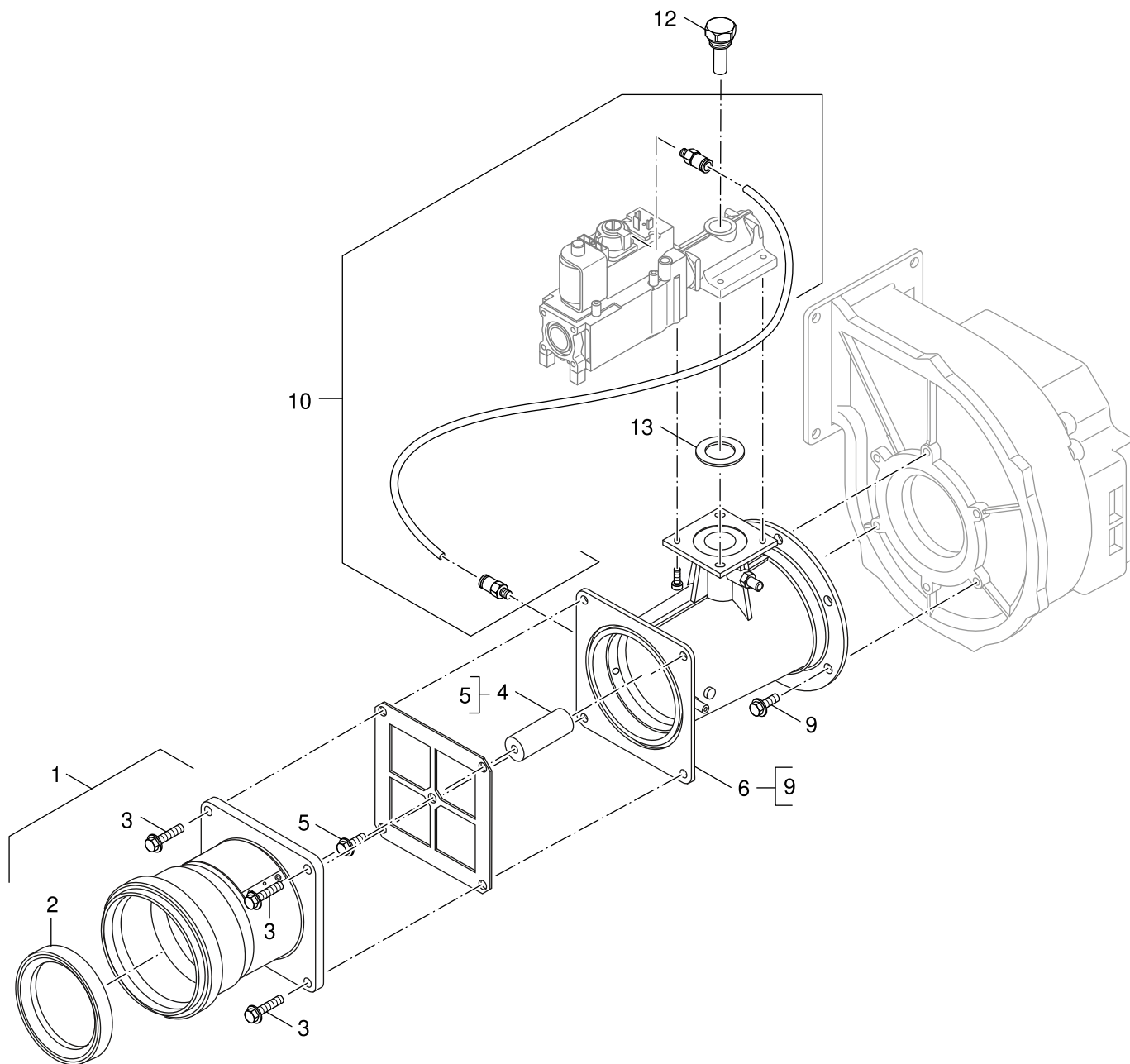

6720906401.aa.RS-Verbrennungsluftzufuhr VR

6B
Verbrennungsluftzufuhr VR
Combustion air supply VR
Alimentation en air de combustion
Adduzione dell'aria comburente
Verbrandingsluchttoevoer
Entrada de aire de combustión

KBR-3
120-280 kW

Pos	Bezeichnung Description Dénomination Descrizioni Benaming Descripción		KBR-3 120 A21	KBR-3 120 A23	KBR-3 160 A21	KBR-3 160 A23	KBR-3 200 A21	KBR-3 200 A23	KBR-3 240 A21	KBR-3 240 A23	KBR-3 280 A21	KBR-3 280 A23							Bemerkungen Remarks Remarques Osservazioni Opmerkingen Observaciones
1	Anschlussstück Zuluft everp	6 303 606 6	■	■	■														
2	Lippendichtung DN110	8 737 711 689	■	■	■														
3	Schraube M8x25 A3K selbstfur everp (5x)	8 718 589 161	■	■	■														
6	Venturi VMU150 V2 (VR) 90/120kW	7 747 002 323	■	■															
6	Venturi VMU185 V2 (VR) 160kW	7 747 002 325			■	■													
9	6kt-Schraube DIN6921 M8x12 (12x)	6 303 612 2	■	■	■														
10	Messleitungen Set V2 (Armatür VR)	7 747 002 340	■	■	■														
12	Gasdrossel D14,50 (VR) 90/120kW	7 747 002 385	■																Schwachgas
12	Gasdrossel D15,00(VR) DE 90/120kW	7 747 002 387	■																EG(G25)
12	Gasdrossel D15,70 (VR) 90/120kW	7 747 002 388		■															EG(G20)
13	Dichtung Venturi everp	6 304 017 9	■	■	■														

**KBR-3
120-280 kW**

Verbrennungsluftzufuhr VR
Combustion air supply VR
Alimentation en air de combustion
Adduzione dell'aria comburente
Verbrandingsluchttoevoer
Entrada de aire de combustión

6B

Ersatzteilliste
Spare parts list

Liste des pièces de rechange
Lista parti di ricambio

Onderdelenlijst
Lista de repuestos

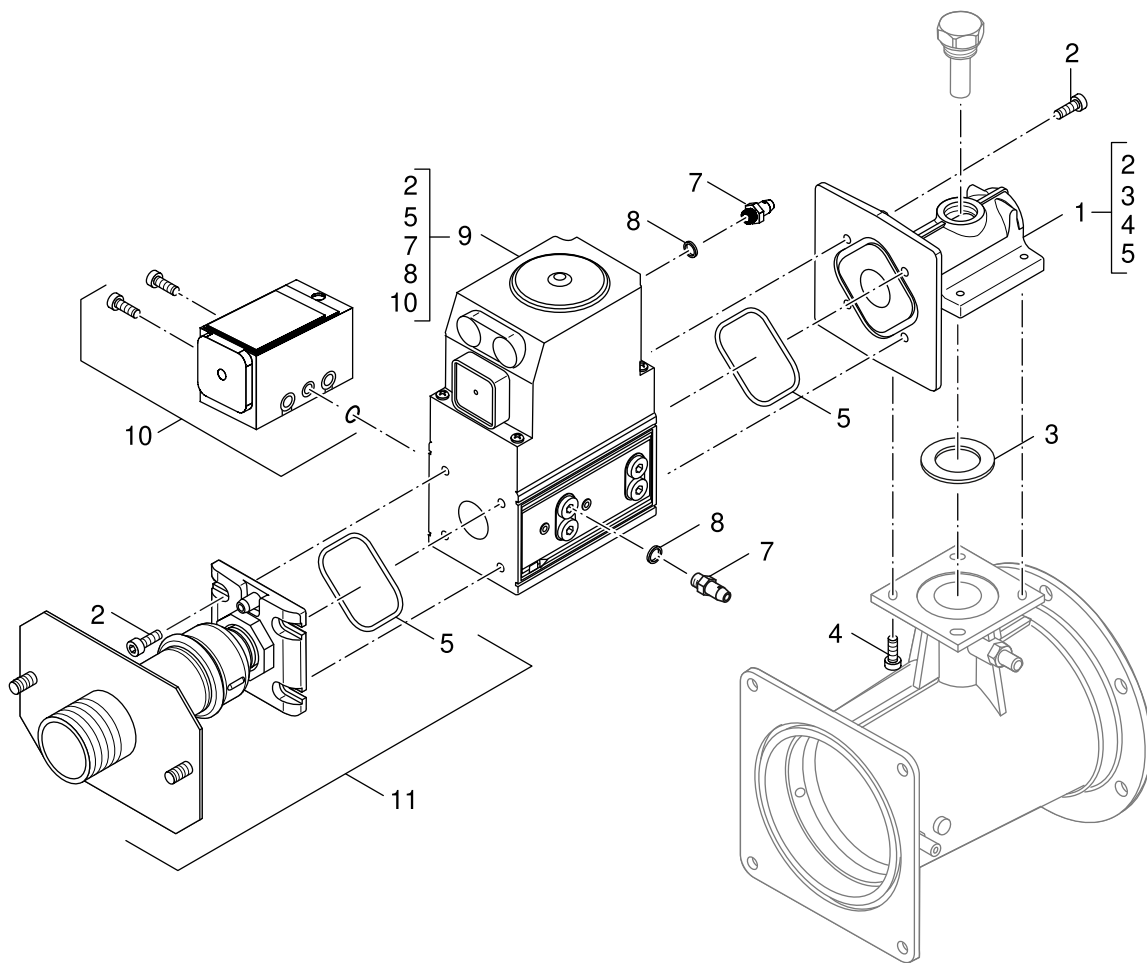

6720906842.aa.RS-Gasarmatur CG20

7A

Gasarmatur CG20
Gas valve CG20
Bloc gaz CG20
Gruppo gas CG20
gasblok CG20
válvula del gas CG20

KBR-3
120-280 kW

Pos	Bezeichnung Description Dénomination Descrizioni Benaming Descripción		KBR-3 120 A21	KBR-3 120 A23	KBR-3 160 A21	KBR-3 160 A23	KBR-3 200 A21	KBR-3 200 A23	KBR-3 240 A21	KBR-3 240 A23	KBR-3 280 A21	KBR-3 280 A23							Bemerkungen Remarks Remarques Osservazioni Opmerkingen Observaciones
1	Adapter CG15/20 everp	6 304 017 7					■	■											
2	Zylinderschraube DIN912 M5x12 (10x)	6 302 287 1					■	■											
3	Dichtung Venturi everp	6 304 017 9					■	■											
4	Zylinderschraube DIN 912 M5x16 (8x)	6 304 009 5					■	■											
5	O-Ring 59x3mm NBR70 CG15/20 (2x)	6 302 036 1					■	■											
7	Druckmessdüse G1/8" everp	8 718 584 783					■	■											
8	Dichtring 10x13,5x1,5 Cu everp	8 718 584 813					■	■											
9	Gasarmatur CG20 200kW	6 303 978 9					■	■											
10	Gasdruckwächter DG35C3D everp	6 302 269 9					■	■											
11	Gasanschlussrohr 200 CG15/20 1 1/4"	8 718 577 953					■	■											

**KBR-3
120-280 kW**

Gasarmatur CG20
Gas valve CG20
Bloc gaz CG20
Gruppo gas CG20
gasblok CG20
válvula del gas CG20

7A

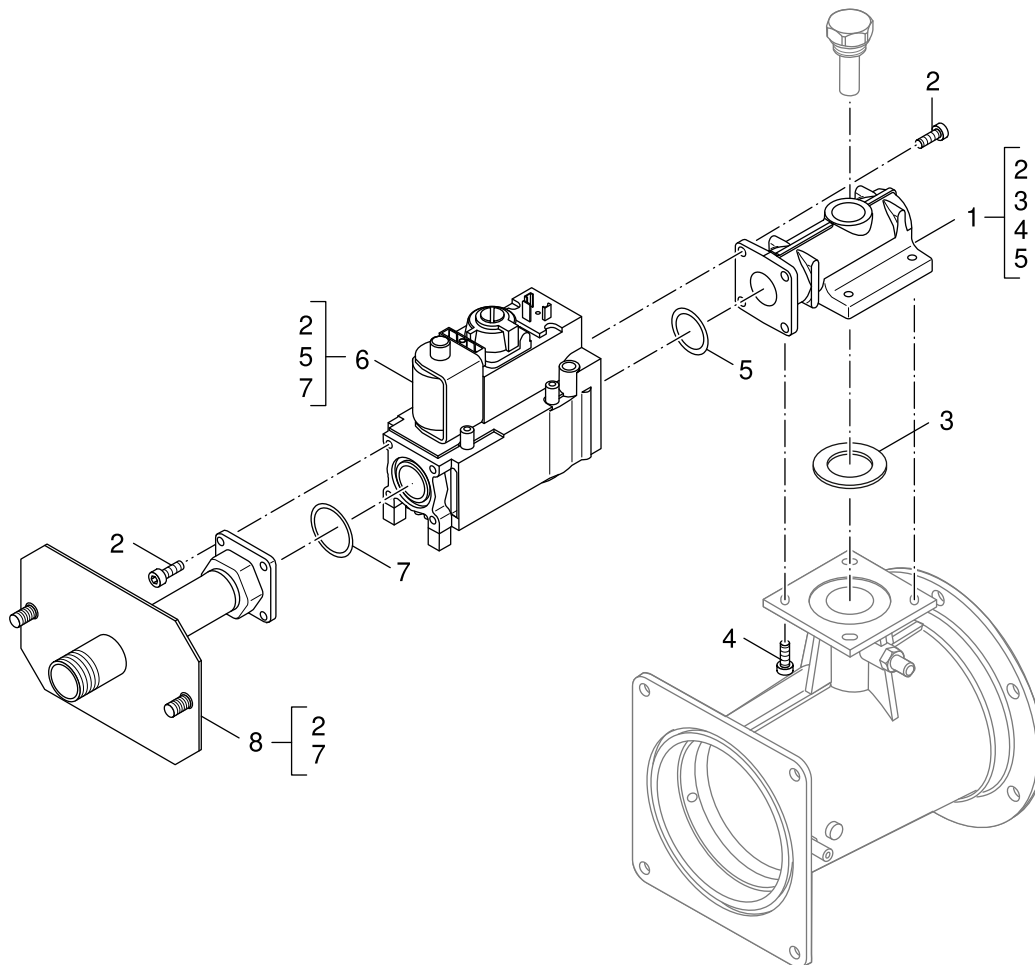

6720906403.aa.RS-Gasarmatur VR4615

7B
Gasarmatur VR4615
Gas valve VR4615
Bloc gaz
Gruppo gas
Gasblok
Válvula del gas

KBR-3
120-280 kW

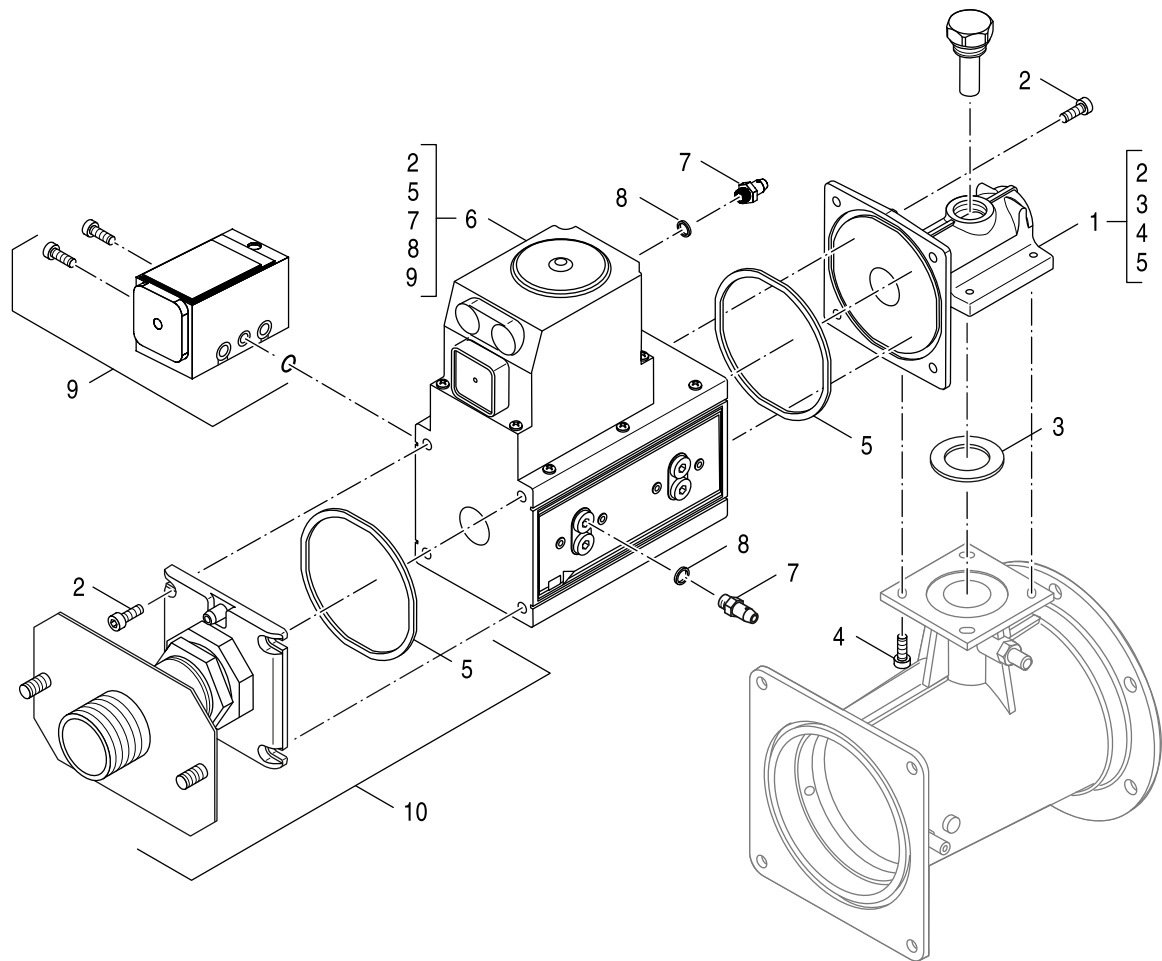

6720906843.aa.RS-Gasarmatur CG25

7C

Gasarmatur CG25
Gas valve CG25
Bloc gaz CG25
Gruppo gas CG25
gasblok CG25
válvula del gas CG25

KBR-3
120-280 kW

Ersatzteilliste
Spare parts list

Liste des pièces de rechange
Lista parti di ricambio

Onderdelenlijst
Lista de repuestos

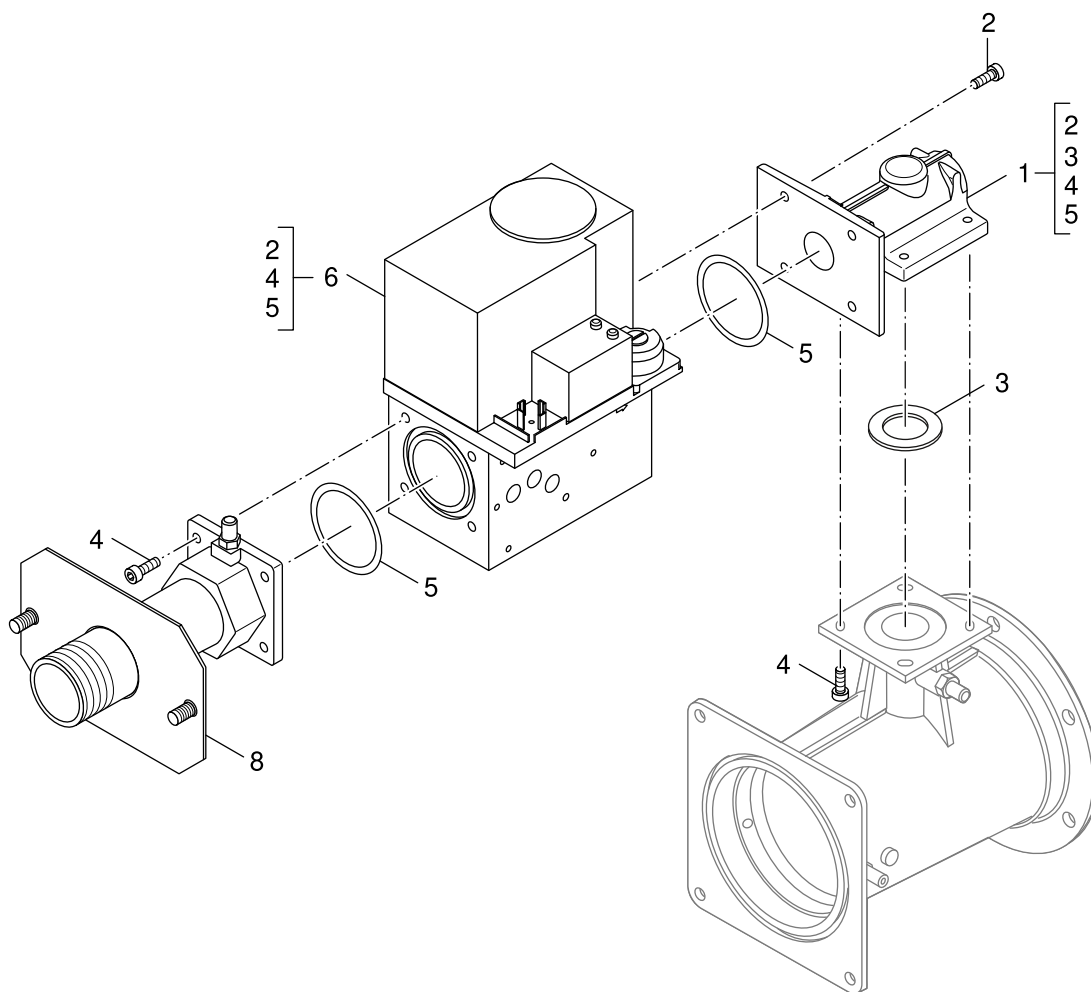

6720906870.aa.RS-Gasarmatur VR

7D

Gasarmatur VR415
Gas valve VR415
Bloc gaz VR415
Gruppo gas VR415
gasblok VR415
válvula del gas VR415

KBR-3
120-280 kW

Pos	Bezeichnung Description Dénomination Descrizioni Benaming Descripción		KBR-3 120 A21	KBR-3 120 A23	KBR-3 160 A21	KBR-3 160 A23	KBR-3 200 A21	KBR-3 200 A23	KBR-3 240 A21	KBR-3 240 A23	KBR-3 280 A21	KBR-3 280 A23							Bemerkungen Remarks Remarques Osservazioni Opmerkingen Observaciones
1	Adapter VR4/VMU everp	7 747 002 333			■	■													
2	Zylinderschraube DIN912 M5x12 (10x)	6 302 287 1			■	■													
3	Dichtung Venturi everp	6 304 017 9			■	■													
4	Zylinderschraube DIN 912 M5x16 (8x)	6 304 009 5			■	■													
5	O-Ring 52,39x3,53 (3x) everp	6 303 606 5			■	■													
6	Armatur VR415 VE 5008 kpl everp	7 747 002 330			■	■													
8	Gasanschlussrohr VR4 everp	7 747 002 347			■	■													

KBR-3 120-280 kW	Gasarmatur VR415 Gas valve VR415 Bloc gaz VR415 Gruppo gas VR415 gasblok VR415 válvula del gas VR415	7D
-----------------------------	---	-----------

Ersatzteilliste
Spare parts list

Liste des pièces de rechange
Lista parti di ricambio

Onderdelenlijst
Lista de repuestos

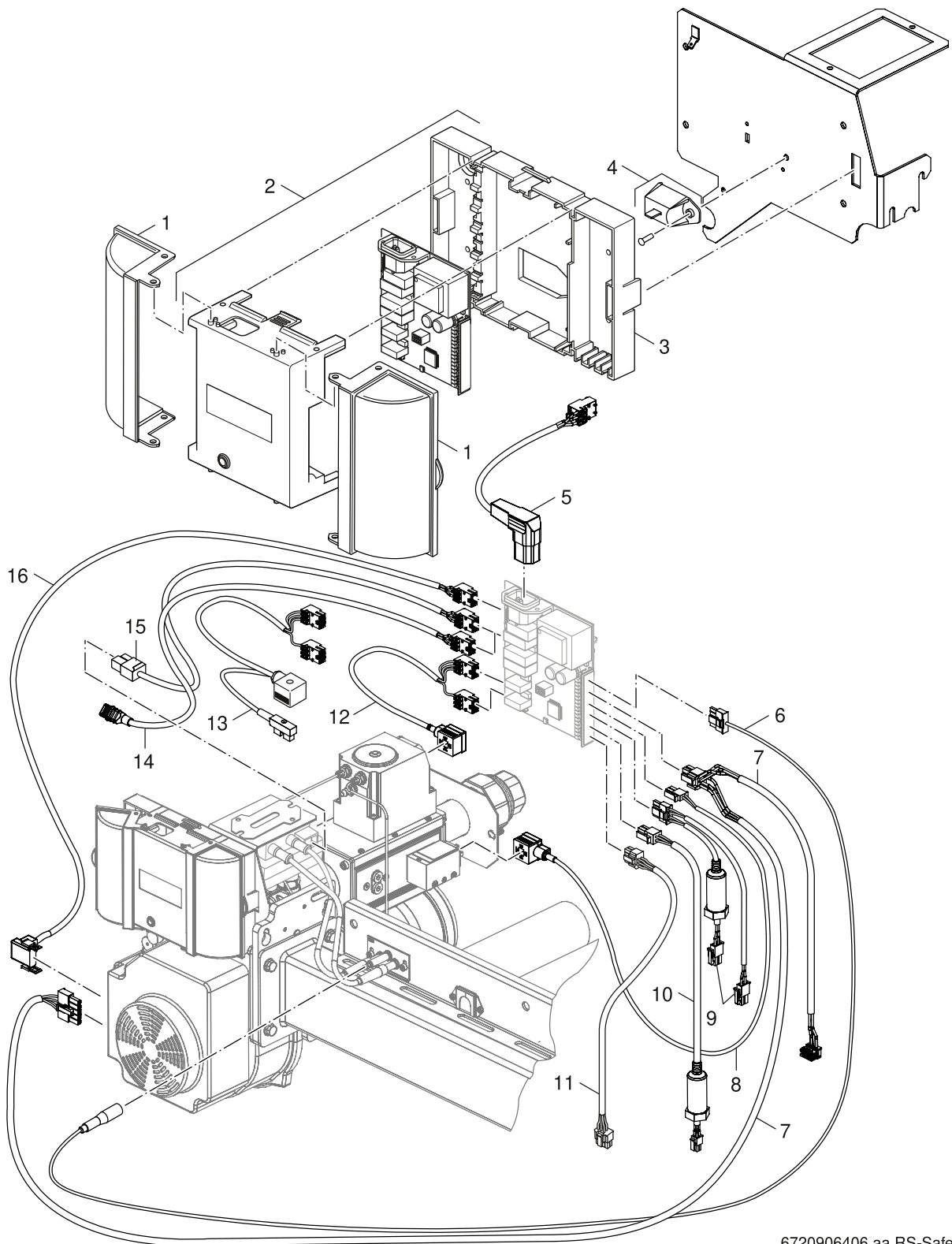

6720906406.aa.RS-Safe40

8

Safe 42M312
Safe 42 VM312
Safe 42 VM312
Safe 42 VM312
Safe 42 VM312

KBR-3
120-280 kW

Pos	Bezeichnung Description Dénomination Descrizioni Benaming Descripción		KBR-3 120 A21	KBR-3 120 A23	KBR-3 160 A21	KBR-3 160 A23	KBR-3 200 A21	KBR-3 200 A23	KBR-3 240 A21	KBR-3 240 A23	KBR-3 280 A21	KBR-3 280 A23							Bemerkungen Remarks Remarques Osservazioni Opmerkingen Observaciones
1	Gehäuse Klemmenabdeckung SAFe everp	6 302 392 5	■	■	■	■	■	■	■	■	■	■							
2	SAFe40 V4/S07 everp	8 738 803 948	■	■	■	■	■	■	■	■	■	■							
3	Nicht mehr lieferbar	8 738 809 949	■	■	■	■	■	■	■	■	■	■							
4	Modul BIM40 V6 120-HW-JKS everp	8 718 594 739	■	■															Nur für Service-Techniker
4	Modul BIM40 V6 160-HW-JKS everp	8 718 594 741			■	■													Nur für Service-Techniker
4	Modul BIM40 V6 200-KRM-JKS everp	8 718 594 742					■	■											Nur für Service-Techniker
4	Modul BIM40 V6 240-KRM-JKS everp	8 718 594 743							■	■									Nur für Service-Techniker
4	Modul BIM40 V6 280-KRM-JKS everp	8 718 594 744									■	■							Nur für Service-Techniker
5	Netzanschlussleitung Kaltgerätest everp	6 302 393 1	■	■	■	■	■	■	■	■	■	■							
6	Ionisation Erdgas 280 everp	6 303 535 3	■	■	■	■	■	■	■	■	■	■							
7	Kabel Gebläse Druckschalter everp	6 303 535 7	■	■	■	■	■	■	■	■	■	■							
8	Verbindungsleitung Gasdruckwächter	6 303 535 6					■	■	■	■	■	■							
9	Verbindungsleitung Fühler Vor/Rücklauf	6 303 535 5	■	■	■	■	■	■	■	■	■	■							
10	Verbindungsleitung Kesselfühler SAFe BE	6 303 921 4	■	■	■	■	■	■	■	■	■	■							
11	Datenleitung SAFe MC10 BE everp	6 303 015 0	■	■	■	■	■	■	■	■	■	■							
12	Verbindungsleitung MV1 VM Brenner everp	6 303 419 5			■	■													
12	Verbindungsleitung Gasarmatur CG	6 303 940 4					■	■	■	■	■	■							
13	Verbindungsleitung Gasarmatur VR4615	6 304 655 9	■	■															
15	Zündleitung SAFe 230V everp	8 738 802 738	■	■	■	■	■	■	■	■	■	■							
16	Verbindungsleitung 230VAC Gebläse	6 303 535 1	■	■	■	■	■	■	■	■	■	■							

**KBR-3
120-280 kW**

Safe 42M312
Safe 42 VM312
Safe 42 VM312
Safe 42 VM312
Safe 42 VM312
Safe 42 VM312

8

Ersatzteilliste
Spare parts list

Liste des pièces de rechange
Lista parti di ricambio

Onderdelenlijst
Lista de repuestos

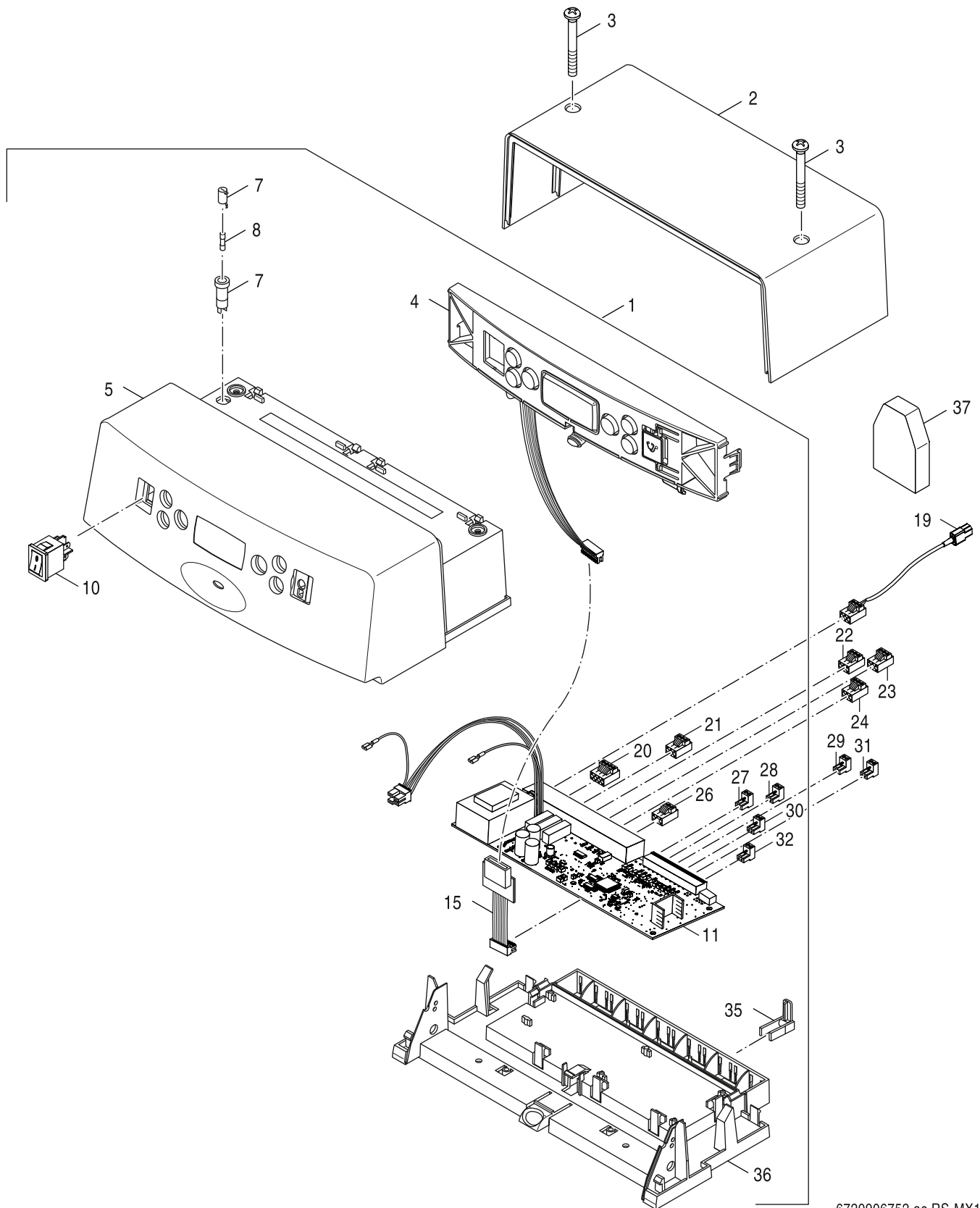

6720906752.ac.RS-MX15

9

MX15
MX15
MX15
MX15
MX15

**KBR-3
120-280 kW**

Übersetzungsliste List of translations		Liste des traductions Traduzione delle descrizioni		Vertalinglijst Lista de traducciones	
Pos	Description	Description	Descrizione	Beschrijving	Descripción
1	Element of construction	Groupe d'assemblage	Gruppo di montaggio	Montage groep	Grupo de montaje
1	Boiler block 4sect V2	Corps chauffe GB312 90-120kW 4 éléments	Corpo caldaia	Ketelblok GB312/120 4LD	Cuerpo caldera 4 elementos V2
1	Boiler block 5sect V2	Corps de chauffe 5 éléments 160kW V2	Corpo caldaia	Ketelblok	Cuerpo caldera 5 elementos V2
1	Boiler block 6sect V2	Corps de chauffe 6 éléments GB312	Corpo caldaia	Ketelblok	Cuerpo caldera 6 elementos V2
1	Boiler block 7sect V2	Corps de chauffe GB312 240KW 7 éléments	Corpo caldaia	Ketelblok	Cuerpo caldera 7 elementos V2
1	Boiler block 8sect V2	Corps de chauffe GB312 280kW 8 éléments	Corpo caldaia	Ketelblok GB312/280 8LD	Cuerpo caldera 8 elementos V2
2	Pipework VK G4 V3	Tube VK G4 V3	Piping G4 V3	Piping G4 V3	Tubería VK 4 elementos V3
2	Pipework VK 5 V3	Tube VK 5 V3	Pipework VK 5 V3	Aanv.Verdeelbuis VK G5 ldn V3 312	Tubería VK 5 elementos V3
2	Pipework VK 6 V3	Tube VK 6 V3	Piping VK 6 V3	Piping VK 6 V3	Tubería VK 6 elementos V3
2	Pipework VK 7 V3	Tube VK 7 V3	Piping VK 7 V3	Piping VK 7 V3	Tubería VK 7 elementos V3
2	Pipework VK 8 V3	Tube VK 8 V3	Piping VK 8 V3	Piping VK 8 V3	Tubería VK 8 elementos V3
3	Installation_kit VK GB312 sp	Jeu de pièces de fixation VK GB312	Set di fissaggio VK GB312	Bevestigingsset VK GB312	Elementos de fijación Termosifón VKGB312
4	Flange 110x110	Bride pleine 110x110	Flangia 110x110	Blindflens 110x110	Brida 110x110
5	cover Cleaning boiler block V4	Trappe de visite V4	Coperchio di pulizia V4	Reinigingsdeksel V4	Tapa de limpieza V4
6	Square-string 10x5 5m silicone self adhe	Joint GB312 10x5 autocollant silicone 5m	Diametralmente 5m GB312	Vierkant silikonensnoer 10x5 GB312 5m	Junta tapas intercambiador calor GB312
7	Cover condensate vat -4sect	Couvercle de la cuve cond. -4Sec	Fuga Cover Pan	Cover drain pan 4	Cubre recipiente de drenaje GB312 4 elem
7	Cover condensate vat -5sect	Couvercle de la cuve cond. -5Sec	Fuga Cover Pan 5	Cover drain pan 5	Cubre recipiente de drenaje GB312 5 elem
7	Cover condensate vat -6/7/8sect	Couvercle de la cuve cond.-6/7/8Sec	Fuga Cover Pan 6/7/8	Cover drain pan 6/7/8	Cubre el recipiente de drenaje GB312
8	Lipseal DN160 Centrotherm	JOINT A LEVRES DN160 CENTROTHERM	Guarnizione ad anello con spigolo di ten	Lippendichting DN160 GB312/4-5	Junta DN160 Centrotherm
8	Lip seal DN200	Joint DN200	Guarnizione DN200	Lipring DN200	Junta DN200
9	Hexagon nut DIN6923 M8 A3K (10x)	Écrou hexagonal DIN6923 M8 A3K (10x)	Dado esagonale DIN6923 M8 A3K (10x)	Zeskantmoer DIN6923 M8 A3K (10x)	Tuerca hexagonal DIN6923 M8 A3K (10x)
10	Throttle R3/4 - D11x63 spare part	Clapet R3 / 4 - D11x63	Valvola a farfalla	Gsinspuitter	Estrangulador R3/4 - D11x63
11	Pipework RK -DN50 V3/V4 everp	Tube RK -DN50 V3/V4	Piping RK DN50 V3/V4	Buisstuk RK GB312-DN50 V3/V4	Tubería RK DN50 V3/V4
11	Pipework RK -DN65 V3/V4 everp	Tube RK DN65 V3/V4	Piping RK DN65 V3/V4	Piping RK DN65 V3/V4	Tubería RK DN65 V3/V4
12	SENSOR G1/4 45mm sp	Sonde de température G1/4 Long.45mm	SENSOR G1/4 45mm	Voeler G1/4 45mm	Sensor individual G1/4 45mm
13	Switch PressureTyp 505.91570 packed	Transmetteur de pression type 505.91570	Transmetteur pression Typ 505.91570 verp	TRANSMETTEUR PRESSION TYP 505.91570	presostato de Seguridad GB312
14	Valve Tap 1/2 W Thread Seal Ring PB2 SP	Robinet de vidange 1/2" PB2	Rubinetto di scarico 1/2" PB2	Ledigingskraan 1/2" PB2	Llave de llenado / vaciado 1/2 PB2
15	GASKET - KLINGERSIL C4400 PN6 DN50	Joint PN6, DN50, 2mm	Guarnizione DIN2690 DN50 PN6 2mm	Vlakdicht. PN6 DN50 GB312/90-120	Junta plana KLINGERSil C4400 DN50
15	Gasket Klingersil C4400 PN6 DN65	Joint PN6, DN65	Guarnizione DIN2690 DN65 PN6 2mm	Vlakdicht. PN6 DN65 GB312/160-280	Junta plana KLINGERSil C4400
16	NON RETURN VALVE DN 50 PN6	Clapet antithermosiphon DN50-pn6	Valvola di ritegno a clapet	Terugslagklep DN50 PN6 GB312	Válvula antirretorno DN 50 PN6
16	NON RETURN VALVE DN 65 PN6	Clapet antithermosiphon DN65-PN6	Valvola di ritegno a clapet	Terugslagklep DN65 PN6 GB312	Válvula antirretorno DN 65 PN7
17	Red-nipple Rp 3/4xG1/4 MS	Nipple de réduction Rp 3/4"xG1/4" (MS)	Nipplo riduttore Rp 3/4"xG1/4" (MS)	Reductienippel Rp 3/4"xG1/4" GB312	Casquillo acoplamiento de sonda

Übersetzungsliste List of translations		Liste des traductions Traduzione delle descrizioni		Vertalinglijst Lista de traducciones	
Pos	Description	Description	Descrizione	Beschrijving	Descripción
18	Sensor boiler G1/4 75lg	Sonde chaudière G1/4 75lg	Sonda caldaia G1/4 75 lun.	Ketelvoeler	Sonda de caldera G 1/4 75mm
19	RESONATOR DIA. 110 X 250 COMPLETE	Résonateur D110x250 compl.	Risonatore D110x250	Resonator D110x250	Retenedor-silenciador D 110x250mm
20	Siphon GB402 looking height 145mm sp	Siphon GB402 145mm	Sifone GB402 145mm	Sifon GB402 145mm	Sifón GB402 145mm
21	Siphon 145mm lock height V2 accessories	Accessoires siphon 145 mm	Accessori Sifone 145mm V2	Toebehoren Sifon 145 GB312	Accesorios Sifón 145mm V2
22	Flue Elbow DN200 With Test Point	Coude de raccordement 87 Grd DN200	Nr. 1623	Boiler poort boeg	Codo de conexión caldera 87° DN200
22	Elbow 87dgr connection 3/4 DN160	Coude 87 Grand raccord 3/4 DN160	Curva 87° 3/4" DN160	Aansluitbocht 87Grd 3/4 DN160 everp	Arco 87° 3/4" DN160
22	Elbow 87dgr connection 3/4 DN200	Coude 87 Grand raccord 3/4 DN200	Curva 87° 3/4" DN200	Aansluitbocht 87Grd 3/4 DN200 everp	Codo 87° conexión 3/4 DN200
22	Elbow 87dgr connection 3/4 DN160/125	Coude 87 Grand raccord 3/4 DN160/125	Curva 87° 3/4" DN160/125	Aansluitbocht 87Grd 3/4 DN160/125 everp	Arco 87° 3/4" DN160/125
23	Hose-angle Ü-nut 3/4	Tuyau	Tubo flessibile	Aansluitslang DN19-Win G3/4" GB312	Muelle 3/4
24	Adapter concentric FC-CA80, DN 80/125	Adaptateur concentr GB125 Ø80 /125	Adattatore-RHF_80/125_PP-rig_GB125BE	Concentrische adapter v GB125 Ø80 /125	FC-CA80 Adaptador KUBC Ø80/125
24	Flue Pipe DN200 With Test Point	Élément droit de raccordement DN200	Nr. 1625	Ketelaansluiting	Conexión caldera recta DN200
24	Pipe Connection 3/4 DN160/125	Tuyau pour bride 3/4 DN160/125	Collegamento tubazione 3/4" DN160/125	Buis 3/4 DN160/125	Unión de tuberías 3/4" DN160/125
24	Pipe Connection 3/4 DN160	Tuyau pour bride 3/4 DN160	Collegamento tubazione 3/4" DN160	Buis	Unión de tuberías 3/4" DN160
24	Pipe Connection 3/4 DN200	Tuyau pour bride 3/4 DN200	Collegamento tubazione 3/4" DN200	Buis	Unión de tuberías 3/4" DN200
25	Foot M10x51 (4x)	Pieds réglables M10x51 (4x)	Piedini regolabili M10x51 (4x)	Voetjes Boiler HP-270-1	Patas regulables M10x51 (4x)
26	Distributor R1	Collecteur R1	Distributore	Kortsluitleiding	Distribuidor R1
26	Distributor R11/4 160-280 sp	Collecteur R11/4 160-280	Distributore R11/4 160-280	Kortsluitleiding R11/4 160-280	Distribuidor R11/4 160-280kW
27	Safety valve	Soupape de sécurité 1	Valvola di sicurezza	Veiligheidsklep	Logafix válvula de seguridad 1" 3bar
28	Air_vent automatic purging system 3/8"	Pot de ventilateur 3/8	Valvola di sfianto 3/8"	Ontluchtingsdeksel 3/8"	Separador de aire 3/8"
29	Pressure gauge for closed conn.,	Manometre pr install fermees 2.5 bar	Manometro 2,5bar 63mm AE D3/8"U	Manometer 2,5bar 63mm AE D3/8"U	Manómetro 2,5bar 63mm AE D3/8"U
30	Hose connector G3/4x20 angled	Embout G3/4x20 équerre	Raccordo ad innesto per tubo flessibile	Slangpilaar G3/4x20 hoeksteun	Embacadura de la manguera G3/4x20 angulo
31	Stud M8x35 5,6 (4x)	Goujon fileté (4x)	Vite prigioniera (4x)	Tapeind (4x)	Tornillo prisionero (4x)
32	Repair set boiler block GB312	Joint de remplacement de chaudière GB312	Blocco caldaia kit Seal GB312	Set dichtingen voor GB312	Juego de reparación bloque de caldera
	Install. mat. expansion vessel V2	Matériel de montage Bouteilles de découp	Crescente pressione vaso di espansione	Bevestigingsmateriaal druk expansievat	Material de montaje vaso de expansión
	Silicone Wezilit EV-300 red to 300°C	Silicone Wezilit EV-300 rouge 300°C	Silicone Wezilit EV-300 rosso sino 300°C	Silicone Wezilit EV-300 rood tot 300°C	Silikon Wezilit EV-300rot bis 300°Ceverp
2A	Element of construction	Groupe d'assemblage	Gruppo di montaggio	Montage groep	Grupo de montaje
1	Panel back up Suprapur 120 KBR-3	PANNEAU SOUTIENT SUPRAPUR 120 KBR-3	Montato sopra	Mounted boven	Montado sobre
1	Panel back up Suprapur 160 KBR-3	PANNEAU SOUTIENT SUPRAPUR 160 KBR-3	Montato sopra	Mounted boven	Montado sobre
1	Panel back up Suprapur 200 KBR-3	PANNEAU SOUTIENT SUPRAPUR 200 KBR-3	Montato sopra	Mounted boven	Montado sobre
1	Panel back up Suprapur 240 KBR-3	PANNEAU SOUTIENT SUPRAPUR 240 KBR-3	Montato sopra	Mounted boven	Montado sobre
1	Panel back up Suprapur 280 KBR-3	PANNEAU SOUTIENT SUPRAPUR 280 KBR-3	Parete posteriore sop Suprapur 280 KBR-3	Achterwand Boven 280 KBR-3	Pared trasera arriba 280 KBR-3
2	Rr panel bottom 120 V2	Dosseret bas 120 V2	Montato sotto 120 V2	Mounted hieronder 120 V2	Pared trasera inferior 120 V2

Übersetzungsliste List of translations		Liste des traductions Traduzione delle descrizioni		Vertalinglijst Lista de traducciones	
Pos	Description	Description	Descrizione	Beschrijving	Descripción
2	Rr panel bottom 160 V2	Dosseret bas 160 V2	Montato sotto 160 V2	Mounted hieronder 160 V2	Pared trasera inferior 160 V2
2	Rr panel bottom 200 V2	Dosseret bas 200 V2	Rr panel bottom 200 V2	Mounted hieronder 200 V2	Panel trasero inferior 200 V2
2	Rr panel bottom 240 V2	HABIL AR 240KW V2	Montato sotto 240KW V2	Mounted hieronder 240KW V2	Panel trasero inferior 240 V2
2	Rr panel bottom 280 V2	Dosseret bas 280 V2	Montato sotto 280 V2	Mounted hieronder 280 V2	Panel trasero inferior 250-300Kw
3	Hood Suprapur 120 KBR-3	Capot	Coperchio	Afdekkap	Capota
3	Hood Suprapur 160-200 KBR-3	Capot	Coperchio	Afdekkap	Capota
3	Hood Suprapur 240-280 KBR-3	Capot	Coperchio	Afdekkap	Capota
4	Cover Anode RAL9016 (2x)	Couvercle RAL9016(2x)	Copertura di protezione RAL9016(2x)	Afdekking RAL9016 (2x)	Recubrimiento RAL9016(2x)
5	Panel side Suprapur 120-280 KBR-3	Paroi latérale	Parete laterale	Zijwand	Pared lateral
6	Panel front Suprapur 120 KBR-3	Couvercle avant	Parete anteriore	Voorwand	Pared delantero
6	Panel front Suprapur 160-200 KBR-3	Couvercle avant	Parete anteriore	Voorwand	Pared delantero
6	Panel front Suprapur 240-280 KBR-3	Couvercle avant	Parete anteriore	Voorwand	Pared delantero
7	Badge "Junkers	Plaque signalétique	Targhetta caldaia	Toestelplaat	Placa del aparato
8	Cross brace up	TRAVERSE DESSUS	Traversa	Kruisbeugel	Perfil de refuerzo
9	Hood Suprapur 120 KBR-3	Capot	Coperchio	Afdekkap	Capota
9	Profile up Suprapur 120KW everp	U-profil haut	U-profile top	U-profiel boven	U-perfil superior
9	Profile up Suprapur 160/200KW everp	U-profil haut	U-profile top	U-profiel boven	U-perfil superior
9	Profile up Suprapur 240/280KW everp	U-profil haut	U-profile top	U-profiel boven	U-perfil superior
10	Stiffening sheet frame GB312	Tole de renfort Cadre GB312	Irrigidimento telaio piatto GB312	Frame verstevigingsplaat GB312	Marco de chapa de refuerzo GB312
11	Cover air conn GB312	Couvercle pour prise d'air GB312	Cover entrata aria GB312	Luchtinlaat dekking GB312	Tapa conector aire GB312
13	Plate cable duct Suprapur FT everp	Chemin de câbles	Canale passacavi	Kabelgoot	Canaleta
14	Pan-head screw ST3,9x9,5 A3T (10x)	Vis à tête plate ST3,9 (10x)	Vite a testa piana ST3,9x9,5 (10x)	Schroef met vlakke kop ST3,9x9,5 (10x)	Tornillo avellanado ST3,9x9,5 (10x)
2B	Element of construction	Groupe d'assemblage	Gruppo di montaggio	Montage groep	Grupo de montaje
1	Insulation boiler block 280	ISOL CORPS CHAUF 280	Di calore della caldaia blocco 280	Warmte ketel te blokkeren 280	Aislante caldera 280kW
1	Insulation boiler block 240	Isolation du bloc chaudière 240	Di calore della caldaia blocco 240	Warmte ketel te blokkeren 240	Aislante caldera 240kW
1	Insulation boiler block 200	Isolation du bloc chaudière 200	Di calore della caldaia blocco 200	Warmte ketel te blokkeren 200	Aislante caldera 200kW
1	Insulation boiler block 160	Isolation du bloc chaudière 160	Di calore della caldaia blocco 160	Warmte ketel te blokkeren 160	Aislante caldera 160kW
1	Insulation boiler block 120	Isolation du bloc chaudière 120	Di calore della caldaia blocco 120	Warmte ketel te blokkeren 120	Aislante caldera 120
2	Thermal insu flow GB312 V2	Isolation avant GB312 V2	Flusso di calore GB312 V2	Warmte-flow GB312 V2	Aislante impulsión GB312 V2
3	Angle thermal insu 280	Angle pour isolation 280	Angolo 280	Beugel voor thermische beveiliging 280	Ángulo para aislante 280kW
3	Angle thermal insu 240	Angle pour isolation 240	Angolo 240	Beugel voor thermische beveiliging 240	Ángulo para aislante 240kW
3	Angle thermal insu 200	Angle pour isolation 200	Angolo 200	Beugel voor thermische beveiliging 200	Ángulo para aislante 200kW

Übersetzungsliste List of translations		Liste des traductions Traduzione delle descrizioni		Vertalinglijst Lista de traducciones	
Pos	Description	Description	Descrizione	Beschrijving	Descripción
3	Angle thermal insu 160	Angle pour isolation 160	Angolo 160	Beugel voor thermische beveiliging 160	Ángulo para aislante 160kW
3	Angle thermal insu 90/120	Angle pour isolation 90/120	Angolo 120	Beugel voor thermische beveiliging 120	Ángulo para aislante 90/122kW
4	Insulation Clamp (10x)	Ressorts de retenue D0.8 (10x)	Molla di tenuta (10x)	Borgveer (10x)	Muelle tensor para aislamientos (10x)
5	Tensi springs	RESSORT DE TENSION GB402	Molla di tensione	Spanveer	Muelle tensor
6	Thermal insulation front GB312-120	ISOLATION AVANT GB402 / GB312-120KW	Isolamento davanti	Isolatie vooraan	Aislante frontal 120kW
6	Thermal insu front 160	ISOLATION AVANT GB402 / GB312-160KW	Thermal insu front 160	Iso.Deken Voorz..GB312-160	Aislante frontal 160kW
6	Thermal insu front 200	ISOLATION AVANT GB402/ GB312 200KW	Thermal insu front 200	Iso.Deken Voorz..GB312-200	Aislante frontal 200kW
6	Thermal insu front 240	ISOLATION AVANT GB402 / GB312-240 KW	Thermal insu front 240	Iso.Deken Voorz..GB312-240	Aislante frontal 240kW
6	Thermal insu front 280	ISOLATION AVANT GB402 / GB312 280 KW	Thermal insu front 280	Isolatie vooraan GB312/280	Aislante frontal 280kW
7	Thermal insulation GB312	Isolatation arrière GB312	Risposta termica GB312	Thermische reactie GB312	Aislante retorno GB312
4	Element of construction	Groupe d'assemblage	Gruppo di montaggio	Montage groep	Grupo de montaje
1	Burner grate 120kW V4	grille de combustion 120kW V4	griglia 120kW V4	branderrooster 120kW V4	óxido de combustión 120kW V4
1	Burner grate 160kW V4	Grille de combustion 160kW V4	griglia 160kW V4	branderrooster 160kW V4	óxido de combustión 160kW V4
1	Burner grate 200kW V4	RAMPE BRULEUR VM312-200 V4	griglia 200kW V4	branderrooster 200kW V4	óxido de combustión 200kW V4
1	Burner grate 240kW V4	Grille de combustion 240kW V4	griglia 240kW V4	branderrooster 240kW V4	óxido de combustión 240kW V4
1	Burner grate 280kW V4	Grille de combustion 280kW V4	griglia 280kW V4	branderrooster 280kW V4	óxido de combustión 280kW V4
2	Fan unit KBR 120 G20 VR V2	Ventilateur KBR 120 G20 VR V2	Ventilatore KBR 120 G20 VR V2	Ventilator KBR 120 G20 VR V2	Ventilador KBR 120 G20 VR V2
2	Fan unit KBR 160 VR V2	Ventilateur KBR 160 VR V2	Ventilatore KBR 160 VR V2	Ventilator KBR 160 VR V2	Ventilador KBR 160 VR V2
2	Fan unit KBR 120kW G25 VR V2	Ventilateur KBR 120kW G25 VR V2	Ventilatore KBR 120kW G25 VR V2	Ventilator KBR 120kW G25 VR V2	Ventilador KBR 120kW G25 VR V2
3	Fan unit KBR 200 CG V2	Ventilateur KBR 200 CG V2	Ventilatore KBR 200 CG V2	Ventilator KBR 200 CG V2	Ventilador KBR 200 CG V2
3	Fan unit KBR 240 CG V2	Ventilateur KBR 240 CG V2	Ventilatore KBR 240 CG V2	Ventilator KBR 240 CG V2	Ventilador KBR 240 CG V2
3	Fan unit KBR 280 CG V2	Ventilateur KBR 280 CG V2	Ventilatore KBR 240 CG V2	Ventilator KBR 280 CG V2	Ventilador KBR 280 CG V2
5A	Element of construction	Groupe d'assemblage	Gruppo di montaggio	Montage groep	Grupo de montaje
1	Seal profile 120	Cordon d'étanchéité profil 90/120	Sealingprofile 120	Dichtingsprofiel vm312-120kw	Junta unión quemador caldera 10x22 - 120
1	Seal profile 160	Cordon d'étanchéité profil 160	Sealingprofile 160	Dichtingsprofiel vm312-160	Junta unión quemador caldera 10x22 - 160
1	Seal profile 200	Cordon d'étanchéité profil 200	Sealingprofile 200	Dichtingsprofiel vm312-200	Junta unión quemador caldera VM312 - 200
1	Seal profile 240	Cordon d'étanchéité profil 240	Sealingprofile 240	Dichtprofiel vm312-240	Junta unión quemador caldera VM312 - 240
1	Seal profile 280	Joint 280	Guarnizione 280	Pakking 280	Junta unión quemador caldera 280
2	thermal insulation 90/120	Isolation thermique 90/120	Isolamento termico 90/120	Isolatie vm312-120kw	Aislante 90/120kW
2	Insulation thermal 160	Isolation thermique 160	Isolamento termico 160	Isolatie vm312-160 compl.	Aislante 160kW
2	Insulation thermal 200	Isolation thermique 200	Isolamento termico 200	Isolatie vm 312-200 compl.	Aislante 200kW
2	Insulation thermal 240	Isolation thermique 240	Isolamento termico 240	Isolatie vm312-240 compl.	Aislante 240kW

Übersetzungsliste List of translations		Liste des traductions Traduzione delle descrizioni		Vertalinglijst Lista de traducciones	
Pos	Description	Description	Descrizione	Beschrijving	Descripción
2	Insulation thermal 280	Isolation thermique 280	Isolamento termico 280	Isolatie vm312-280 compl.	Aislante 280kW
3	Ceramic adhesives Thermofix tube 115gr	Tube colle céramique THERMOFIX 115Gr	Ceramica Adesivo Thermofix 115gr.	Keramiek Lijm Thermofix 115gr.	Pegamento cerámico tubo de 115 gr.
4	burner rod V5 (Metall)	Rampe de combustion V5	torcia del bruciatore V5	staaftbrander V5	barra combustible V5
5	Seal Burner tube	Joint de tube de brûleur	Guarnizione Raccordo bruciatore	Dichting voor branderstaaf	Junta cañón quemador
6	Nut EN 1661 M5 10 A3K	Écrou EN 1661 M5 10 A3K	Dado EN 1661 M5 10 A3K	Moer EN 1661 M5 10 A3K	Tuerca hexagonal EN1661 M5 10 A3K
7	Ignition Set VM312 V5	Kit électrode + tube V5	Set accensione VM312 V5	onsteek set VM312 V5	Kit Cambio Quemador GB312 a V5
5B	Element of construction	Groupe d'assemblage	Gruppo di montaggio	Montage groep	Grupo de montaje
1	Tube distributor 90/120 VR	Rampe injecteur 90/120 VR	Tubo di distribuzione 90/120 VR	Spruit stuk 90/120 VR	Tubo distribución 90/120 VR
2	Tube distributor 160 CG/VR	Rampe injecteur 160 CG/VR	Tubo di distribuzione 160 CG/VR	Spruit stuk 160 CG/VR	Tubo distribución 160 CG/VR
2	Tube distributor 200 CG/VR	Rampe injecteur 200 CG/VR	Tubo di distribuzione 200 CG/VR	Spruit stuk 200 CG/VR	Tubo distribución 200 CG/VR
2	Tube distributor 240 CG/VR	Rampe injecteur 240 CG/VR	Tubo di distribuzione 240 CG/VR	Spruit stuk 240 CG/VR	Tubo distribución 240 CG/VR
3	Tube distributor 280 CG/VR	Rampe injecteur 280 CG/VR	Tubo di distribuzione 280 CG/VR	Spruit stuk 280 CG/VR	Tubo distribución 280 CG/VR
4	Pressure tapping G1/8"	Prise de pression G1/8"	Presa pressione G1/8"	Meetnippel gasklep G1/8"	Toma presiones 1/8
5	Washer 10x13,5x1,5 Cu	Joint 10x13,5x1,5 Cu	Guarnizione 10x13,5x1,5 Cu	Dichtring 10x13,5x1,5 Cu GASKLEP	Junta tórica 10x13.5mm para toma presion
6	Inspection window	Hublot	Vetrino	Kijkglas vm312 compl.	Mirilla de inspección
7	Screw DIN7500 M4x12 A3K Torx(4x)	Vis DIN7500 M4x12 A3K Torx(4x)	Vite DIN7500 M4x12 A3K Torx(4x)	Schroef DIN7500 M4x12 A3K Torx(4x)	Tornillo DIN7500 M4x12 A3K Torx(4x)
8	Glass pane 30x30x3,3mm repl pack	Vitre en verre 30x30x3,3mm	Lastra di vetro 30x30x3,3mm	Glasvenster 30x30x3,3mm	Mirilla 30x30x3,3mm
9	hexagon- head screw DIN 6921 M8x12 (12x)	Vis à tête hexagone DIN 6921 M8X12 (12X)	Vite esagonale DIN 6921 M8x12 (12x)	6KT-bout DIN 6921 M8x12 (12x)	Tornillo hexagonal DIN 6921 M8x12 (12x)
10	Sealing burner fixture 12mm	Joint 12mm	Guarnizione 12mm	Dichting Branderklem	Junta unión a ventilador 12mm GB312
11	Mounting bracket Burner VM312	Support Brûleur VM312	Supporto Bruciatore VM312	Houder Brander VM312	Soporte Quemador VM312
5C	Element of construction	Groupe d'assemblage	Gruppo di montaggio	Montage groep	Grupo de montaje
1	Ignition electrode V5	Électrode d'allumage V5	elettrodo di accensione V5	ontstekingselektrode V5	electrodo de encendido V5
3	Cylinder head screw DIN912 M5x12 (10x)	Vis cylindrique DIN912 M5x12 (10x)	Cylinder head screw DIN912 M5x12 (10x)	Cylinder head screw DIN912 M5x12 (10x)	Tornillo DIN912 M5x12 (10x)
6	Gloeikabel vm312 D7 SD6,3 SD4	Câble d'allumage D7 SD6,3 SD4	Cavetto accensione D7 SD6,3 SD4	Ontstekingskabel D7 SD6,3 SD4	Cable de encendido D7 SD6,3 SD4
7	Washer DIN6797 A5,3 A3K (5x)	disque denté DIN6797 A5,3 A3K (5x)	Cog ruota DIN6797 A5,3 A3K (5x)	Tandwiel DIN6797 A5,3 A3K (5x)	Arandela dentada DIN6797 A5,3 A3K (5x)
8	Ignition transf MCT TYP ZA20120A11-01/TS	Transformateur allumage brûleur MCT TYP	dispositivo di accensione MCT TypZA20120	ontstekingsunit MCT Typ ZA20120A11-01/TS	Transformador de encendido MCT Typ
10	Screw DIN7500 M5x12 Torx (15x)	VIS DIN7500 CE M5x12 COMBI TORX (15X)	Vite M5x12 Kombi Torx (15x)	Schroef M5x12 Kombi Torx (15x)	Tornillo M5x12 Kombi Torx (15x)
11	Fan ebm G1G170-AB31-WW	Ventilateur ebm G1G170-AB31 GB312 V2	Ventilatore	Ventilator	Ventilador GB312 EBM G1G170-AB31-WW
12	hexagon- head screw DIN 6921 M8x12 (12x)	Vis à tête hexagone DIN 6921 M8X12 (12X)	Vite esagonale DIN 6921 M8x12 (12x)	6KT-bout DIN 6921 M8x12 (12x)	Tornillo hexagonal DIN 6921 M8x12 (12x)
13	Sealing burner fixture 12mm	Joint 12mm	Guarnizione 12mm	Dichting Branderklem	Junta unión a ventilador 12mm GB312
14	Bracket SAFE	Plaque de jonction	Lamierino	Houderplaat	Placa de unión
6A	Element of construction	Groupe d'assemblage	Gruppo di montaggio	Montage groep	Grupo de montaje

Übersetzungsliste List of translations		Liste des traductions Traduzione delle descrizioni		Vertalinglijst Lista de traducciones	
Pos	Description	Description	Descrizione	Beschrijving	Descripción
1	connector	Raccord air entrant VM312 complet	Raccordo	Aansluitstuk	Racor
2	Lip seal DN110	Joint DN110	Guarnizione DN110	Lipring DN110	Junta DN110
3	Screw M8x25 A3K (5x)	vis M8x25 A3K (5x)	vite M8x25 A3K (5x)	schroef M8x25 A3K (5x)	Tornillo M8x25 A3K (5x)
4	Air throttle D20	CLAPET D'AIR D20	Valvola a farfalla D20	Gasinspuitter D20	Estrangulación de aire D20
4	Air throttle D25	CLAPET D'AIR D25	Valvola a a farfalla D25	Gasinspuitter D25	Estrangulación de aire D25
5	hexagon- head screw DIN 6921 M8x12 (12x)	Vis à tête hexagone DIN 6921 M8X12 (12X)	Vite esagonale DIN 6921 M8x12 (12x)	6KT-bout DIN 6921 M8x12 (12x)	Tornillo hexagonal DIN 6921 M8x12 (12x)
6	Venturi MU300 (CG) 200-280kW	Venturi MU300 (CG) 200-280kW	Venturi MU300 (CG) 200-280kW	Venturi MU300 (CG) 200-280kW	Venturi MU300 (CG) 200-280kW
7	hexagon- head screw DIN 6921 M8x12 (12x)	Vis à tête hexagone DIN 6921 M8X12 (12X)	Vite esagonale DIN 6921 M8x12 (12x)	6KT-bout DIN 6921 M8x12 (12x)	Tornillo hexagonal DIN 6921 M8x12 (12x)
8	MEASURING CAPILLARY SET V1 (CG)	Kit conduites venturi v1 (cg)	MEASURING CAPILLARY SET V1 (CG)	Meetleidingen GB312 (Armatuur CG)	Kit manguitos V1 (válvula CG)
11	gas throttle D12,60	Réglage de gaz D12,60	Valvola a farfalla D12,60	Gashuiskap D12,60	Estrangulador de gas D12,60
11	gas throttle D13,60	Réglage de gaz D13,60	Valvola a farfalla D13,60	Gashuiskap D13,60	Estrangulador de gas D13,60
11	gas throttle D14,20	Réglage de gaz D14,20	Valvola a farfalla D14,20	Gashuiskap D14,20	Estrangulador de gas D14,20
12	Seal Venturi	Joint Venturi	Guarnizione Venturi	Dichting voor ventilator GB312	Junta Venturi valvula de gas GB312
6B	Element of construction	Groupe d'assemblage	Gruppo di montaggio	Montage groep	Grupo de montaje
1	connector	Raccord air entrant VM312 complet	Raccordo	Aansluitstuk	Racor
2	Lip seal DN110	Joint DN110	Guarnizione DN110	Lipring DN110	Junta DN110
3	Screw M8x25 A3K (5x)	vis M8x25 A3K (5x)	vite M8x25 A3K (5x)	schroef M8x25 A3K (5x)	Tornillo M8x25 A3K (5x)
6	Venturi VMU150 V2 (VR) 90/120kW	Venturi VMU150 V2 (VR)90/120kW	Venturi VMU150 V2 (VR) 90/120kW	Venturi VMU150 V2 (VR)90/120kW	Venturi VMU150 V2 (VR) 90/120kW
6	Venturi VMU185 V2 (VR) 160kW	Venturi VMU185 V2 (VR) 160kW	Venturi VMU185 V2 (VR) 160kW	Venturi VMU185 V2 (VR) 160kW	Venturi VMU185 (VR) 160kW
9	hexagon- head screw DIN 6921 M8x12 (12x)	Vis à tête hexagone DIN 6921 M8X12 (12X)	Vite esagonale DIN 6921 M8x12 (12x)	6KT-bout DIN 6921 M8x12 (12x)	Tornillo hexagonal DIN 6921 M8x12 (12x)
10	Measuring capillary set V2 Hon cpl	Kit conduites Venturi V2 (VR)	Measuring capillary set V2 Hon cpl	Meetleiding Set VM312 V2 (Armatuur VR)	Kit manguitos V2 (válvula VR)
12	gas throttle D14,50	Réglage de gaz D14,50	Valvola a farfalla D14,50	Gashuiskap D14,50	Estrangulador de gas D14,50
12	gas throttle D15,00	Réglage de gaz D15,00	Valvola a farfalla D15,00	Gashuiskap D15,00	Estrangulador de gas D15,00
12	gas throttle D15,70	Réglage de gaz D15,70	Valvola a farfalla D15,70	Gashuiskap D15,70	Estrangulador de gas D15,70
13	Seal Venturi	Joint Venturi	Guarnizione Venturi	Dichting voor ventilator GB312	Junta Venturi valvula de gas GB312
7A	Element of construction	Groupe d'assemblage	Gruppo di montaggio	Montage groep	Grupo de montaje
1	ADAPTER CG15/20 COMPLETE	Adaptateur CG15/20	ADAPTER CG15/20 COMPLETE	Adapter CG15/20	Adaptador completo CG15/20
2	Cylinder head screw DIN912 M5x12 (10x)	Vis cylindrique DIN912 M5x12 (10x)	Cylinder head screw DIN912 M5x12 (10x)	Cylinder head screw DIN912 M5x12 (10x)	Tornillo DIN912 M5x12 (10x)
3	Seal Venturi	Joint Venturi	Guarnizione Venturi	Dichting voor ventilator GB312	Junta Venturi valvula de gas GB312
4	cheese- head screw DIN 912 M5x16 (8x)	Fillister(cheese)-head DIN 912 M5x16(8x)	cheese- head screw DIN 912 M5x16 (8x)	Cilinderschroef DIN 912 M5x16(8x)	Tornillo DIN 912 M5x16 (8x)
5	O-ring 59x3mm NBR70 CG15/20 kit 2 Piece	O-RING CG15/20 (2x)	O-Ring 59x3mm NBR70 CG15/20 (2x)	O-ring 59x3mm NBR70 CG15/20 (2x)	Anillo tórico 59x3mm NBR70 CG15/20 (2x)
7	Pressure tapping G1/8"	Prise de pression G1/8"	Presa pressione G1/8"	Meetnippel gasklep G1/8"	Toma presiones 1/8

Übersetzungsliste List of translations		Liste des traductions Traduzione delle descrizioni		Vertalinglijst Lista de traducciones	
Pos	Description	Description	Descrizione	Beschrijving	Descripción
8	Washer 10x13,5x1,5 Cu	Joint 10x13,5x1,5 Cu	Guarnizione 10x13,5x1,5 Cu	Dichtring 10x13,5x1,5 Cu GASKLEP	Junta tórica 10x13.5mm para toma presion
9	Gas valve CG20 200kW	Bloc gaz CG20 200kW	Gruppo gas CG20 200kW	Gasklep CG 20 200kW GB312	Válvula de gas CG20 200kW
10	Gasdrukwachter dg35c3d compl.	Pressostat dg35c3d complet	Gas governor DG35C3D with O-ring and	Gasdrukwachter GB312 DG35C3D	Presostato de gas DG35C3D
11	Gas supply pipe 200 CG15/20 1 1/4	Tube gaz 200 CG15/20 1 1/4"	Tubo gas 200 CG15/20 1 1/4"	Gaspijp 200 CG15/20 1 1/4"	Tubo de gas 200 CG15/20 1 1/4"
7B	Element of construction	Groupe d'assemblage	Gruppo di montaggio	Montage groep	Grupo de montaje
1	Adaptor VR46/VMU	Adaptateur VR46/VMU	Adaptor VR46/VMU	Adapter VR46/VMU	Adaptador VR46/VMU
2	Cylinder head screw DIN912 M5x12 (10x)	Vis cylindrique DIN912 M5x12 (10x)	Cylinder head screw DIN912 M5x12 (10x)	Cylinder head screw DIN912 M5x12 (10x)	Tornillo DIN912 M5x12 (10x)
3	Seal Venturi	Joint Venturi	Guarnizione Venturi	Dichting voor ventilator GB312	Junta Venturi valvula de gas GB312
4	cheese- head screw DIN 912 M5x16 (8x)	Fillister(cheese)-head DIN 912 M5x16(8x)	cheese- head screw DIN 912 M5x16 (8x)	Cilinderschroef DIN 912 M5x16(8x)	Tornillo DIN 912 M5x16 (8x)
5	o-ring 26,57x3,53 DVGW (5x)	Joint torique 26,57x3,53 DVGW (5x)	o-ring 26,57x3,53 DVGW (5x)	O-ring 26,57x3,53 DVGW (5x)	anillo tórico 26,57x3,53 DVGW (5x)
6	Valve VVR4615 GB312 90-120	Bloc gaz VR4615 GB312-90/120kW Honeywell	Valve VR4615 GB312 90-120	Gasklep VR4615 1000 kpl GB312/90-120	Válvula de gas VR4615 GB312 90-120
7	O-ring HON V44	Joint torique bloc HON V44	Anello tenuta HON V44	O-ring voor gasblok HON V44	Anillo tórico válvula V44
8	gas pipe VR4615	Tube gaz VR4615	Tubo gas VR4615	Gaspijp VR4615	Tubo de gas VR4615
7C	Element of construction	Groupe d'assemblage	Gruppo di montaggio	Montage groep	Grupo de montaje
1	ADAPTER CG25 COMPLETE	Adaptateur CG25	ADAPTER CG25 COMPLETE	Adapter CG25	Adaptador completo CG25
2	Cylinder head screw DIN912 M6x16 8,8	Vis cylindrique DIN912 M6x16 (10x)	Cylinder head screw DIN912 M6x16 (10x)	Cilinderschroef DIN912 M6x16 (10x)	Tornillo DIN912 M6x16 (10x)
3	Seal Venturi	Joint Venturi	Guarnizione Venturi	Dichting voor ventilator GB312	Junta Venturi valvula de gas GB312
4	cheese- head screw DIN 912 M5x16 (8x)	Fillister(cheese)-head DIN 912 M5x16(8x)	cheese- head screw DIN 912 M5x16 (8x)	Cilinderschroef DIN 912 M5x16(8x)	Tornillo DIN 912 M5x16 (8x)
5	O-ring 87x3mm NBR70 CG25 kit (2x)	Torique 87X3mm NBR70 CG25 (2x)	O-Ring 87x3mm NBR70 CG25 (2x)	O-ring 87x3mm NBR70 CG25 (2x)	Manguito roscado doble NBR70 CG25 (2x)
6	Gas valve CG25 240/280kW	Bloc gaz CG25 240/280kW	Gruppo gas CG25 240/280kW	Gasklep CG 25 240/280kW GB312	Válvula de gas CG25 240/280kW
7	Pressure tapping G1/8"	Prise de pression G1/8"	Presa pressione G1/8"	Meetnippel gasklep G1/8"	Toma presiones 1/8
8	Washer 10x13,5x1,5 Cu	Joint 10x13,5x1,5 Cu	Guarnizione 10x13,5x1,5 Cu	Dichtring 10x13,5x1,5 Cu GASKLEP	Junta tórica 10x13.5mm para toma presion
9	Gasdrukwachter dg35c3d compl.	Pressostat dg35c3d complet	Gas governor DG35C3D with O-ring and	Gasdrukwachter GB312 DG35C3D	Presostato de gas DG35C3D
10	Pipe gas 240-280 CG25 1 1/4	Tube gaz 240-280 CG25 1 1/4	Tubo gas 240-280 CG25 1 1/4	Gaspijp 240-280 CG25 1 1/4	tubo de gas 240-280 CG25 1 1/4
7D	Element of construction	Groupe d'assemblage	Gruppo di montaggio	Montage groep	Grupo de montaje
1	Adaptor VR4/VMU	Adaptateur VR4/VMU	Adaptor VR4/VMU	Adapter VR4/VMU	Adaptador VR4/VMU
2	Cylinder head screw DIN912 M5x12 (10x)	Vis cylindrique DIN912 M5x12 (10x)	Cylinder head screw DIN912 M5x12 (10x)	Cylinder head screw DIN912 M5x12 (10x)	Tornillo DIN912 M5x12 (10x)
3	Seal Venturi	Joint Venturi	Guarnizione Venturi	Dichting voor ventilator GB312	Junta Venturi valvula de gas GB312
4	cheese- head screw DIN 912 M5x16 (8x)	Fillister(cheese)-head DIN 912 M5x16(8x)	cheese- head screw DIN 912 M5x16 (8x)	Cilinderschroef DIN 912 M5x16(8x)	Tornillo DIN 912 M5x16 (8x)
5	O-ring 52,39x3,53 (3x)	Joint torique 52,39x3,53 (3x)	Anello tenuta 52,39x3,53 (3x)	O-ring 52,39x3,53 (3x)	Anillo tórico 52,39x3,53 (3x)
6	Valve VR415 VE 5008 cpl	Bloc gaz VR415 VE5008	Valve VR415 VE 5008 cpl	Gasklep VR415 Kpl GB312/160	Válvula VR415 VE5008
8	gas pipe VR415/420/425	Tube gaz VR415/420/425	Tubo gas VR415/420/425	Gaspijp VR415/420/425	Tubo de gas VR415/420/425

Übersetzungsliste List of translations		Liste des traductions Traduzione delle descrizioni		Vertalinglijst Lista de traducciones	
Pos	Description	Description	Descrizione	Beschrijving	Descripción
8	Element of construction	Groupe d'assemblage	Gruppo di montaggio	Montage groep	Grupo de montaje
1	Housing Terminal cover SAFe	Couvercle safe GB402	Coperchio SAFe	Behuizing klemmenstrook SAFe	Carcasa cubre conexiones SAFE
2	SAFe40 V4/S07	SAFe40 V4/S07	SAFe40 V4/S07	SAFe40 V4/S07	SAFe40 V4/S07
3	No longer available	Plus disponible	Non più disponibile	Niet langer beschikbaar	Ya no disponible
4	Module BIM40 V6 -120-JKS	module BIM40 V6 120-JKS	Modulo BIM40 V6 120-JKS	module BIM40 V6 120-JKS	módulo BIM40 V6 120-JKS
4	Module BIM40 V6 -160-JKS	module BIM40 V6 -160-JKS	Modulo BIM40 V6 -160-JKS	module BIM40 V6 -160-JKS	módulo BIM40 V6 -160-JKS
4	Module BIM40 V6 -200-KRM-JKS	module BIM40 V6 200-KRM-JKS	Modulo BIM40 V6 200-KRM-JKS	module BIM40 V6 200-KRM-JKS	módulo BIM40 V6 200-KRM-JKS
4	Module BIM40 V6 -240-KRM-JKS	module BIM40 V6 240-KRM-JKS	Modulo BIM40 V6 240-KRM-JKS	module BIM40 V6 240-KRM-JKS	módulo BIM40 V6 240-KRM-JKS
4	Module BIM40 V6 -280-KRM-JKS	module BIM40 V6 280-KRM-JKS	Modulo BIM40 V6 280-KRM-JKS	module BIM40 V6 280-KRM-JKS	módulo BIM40 V6 280-KRM-JKS
5	Mains supply cable inlet connector for	Cordon branchement reseau	Cavo di rete	Netaansluitleiding koudetest G135	Cable conexión red SAFe
6	Ionisation N/gas harness	Câbles d'ionisation EG	Cablaggio ionizzazione EG	Ionisatieleiding GB312	Cables de ionización gas natural 280
7	Connecting lead fan / pressure switch	Câble de connexion ventilateur GB312	Cavo ventilador Pressostato	Kabel Ventilator Drukverschilschakelaar	Cable de conexión ventilador PWM WIDW
8	Verb.leiding gasdrukwachter	Conduite de raccordement	Tubazione di collegamento	Verbindingsleiding gasdrukwachter GB312	Cable de conexión presostato de gas
9	return sensor harness	Conduite de raccordement départ/retour	Tubazione di collegamento mandata/ritorn	Verbind.leiding vertrek/retour voel.	Cable de conexión sonda
10	Con cable sensor SAFeBE grommet	Câble SAFe - sonde chaudière	Tubazione di collegamento SAFe BE	Verbind.leiding ketelvoel/Safe GB312	Cable de conexión sonda SAFe BE
11	Data cable SAFe MC10 BE	Câble bus données SAFe - MC10	Tubazione di collegamento SAFe MC10 BE	Verbindingsleiding Safe MC10 BE	Cable de datos SAFe MC 10 BE
12	connecting cable MV1 VM	Conduite de raccordement MV1 VM	Tubazione di collegamento MV1 VM	Verbindingsleiding MV1 VM	Cable de conexión válvula gas
12	Connecting cable CG	Câble de connexion bloc gaz CG	Tubazione di collegamento CG	Verbindingsleiding gasklep GB312	Cable de conexión válvula CG
13	connecting cable VR4615	Conduite de raccordement VR4615	Tubazione di collegamento VR4615	Verbindingsleiding VR4615	Cable de conexión VR4615
15	Ignition cable SAFe 230 V	Câble d'allumage SAFe 230 V	Cavetto accensione SAFe 230V	Ontstekingskabel SAFe 230V everp	Cable de encendido RE/DE/SE
16	Verb.leiding 230vac ventilator	Conduite de raccordement 230VAC Ventila	Tubazione di collegamento 230VAC Ventila	Verbindingsleiding 230V Ventilator GB312	Cable de conexión 230VAC ventilador
9	Element of construction	Groupe d'assemblage	Gruppo di montaggio	Montage groep	Grupo de montaje
1	Control_unit MX15 S22 everp	Appareil de régulation MXx15 S22	Control_unit MX15 S22 everp	Regeling MX15 S22	Aparato de regulación MX15 S22
2	Housing Hood white	Carter capot blanc	Copertura involucro bianco	Huis kap wit	Cubierta superior blanca
3	Screw KB50x35/20 (4Pc)	Vis KB50x35/20 (4x)	Vite KB50x35/20 (4x)	Schroef KB50x35/20 (4x)	Tornillo KB50x35/20 (4x)
4	Control_panel interface MX15 V2 everp	Tableau de commande MX15	Pannello di comando MX15	Bedieningspaneel MX15	Cuado de maniobra MX15
5	Housing MX/HX15	Partie supérieure MX/HX15	Parte superiore MX/HX15	Bovendeel MX/HX15	parte superior MX/HX15
7	Fuse holder 230V 5x20mm	Support de fusible 230V 5x20mm	Porta fusibile 230V 5x20mm	Zekeringhouder 230V 5x20mm	portafusible 230V 5x20mm
8	Fuse application 5x20 6,3AT 230V (10x)	Fusible arrière 5x20 6,3AT 230V (10x)	Fusibile posteriore 5x20 6,3AT 230V(10x)	Buissmeltveiligh. Achter 5x20 6,3AT 230V	Fusible 5x20 6,3AT 230V (10x)
10	Powerswitch	Interrupteur	Interruttore	Schakelaar	Interruptor
11	PCB circuit board MX15 V2 everp	Circuit imprimé MX15	Circuito stampato MX15	Printplaat MX15	Placa electrónica MX15
15	Adaptor data cable	Raccord ligne de transmissi. des données	Adattore linea dati	Adapter gegevensleiding	adaptador línea de datos

Übersetzungsliste List of translations		Liste des traductions Traduzione delle descrizioni		Vertalinglijst Lista de traducciones	
Pos	Description	Description	Descrizione	Beschrijving	Descripción
19	Mains supply cable inlet connector for	Cordon branchement reseau	Cavo di rete	Netaansluitleiding koudetest G135	Cable conexión red SAFe
20	Connector 4-pol 17B18 orange	Borne de raccorderne 4 poles 17B18 orange	Morsetto di collegamento 4-pol. 17B18	Aansluitklem 4-pol. 17B18 oranje	Borne de conexión 4- polos anaranjado
21	Connector 3-pole white	Borne de connexion 3 pôles blanc	Morsetto di collegamento 3-bipol. bianco	Aansluitklem 3-polig wit	Connector 3-pole white
22	Connecting terminal pluggable 3-pol	Borne de connexion 3- pôles jaune	Morsetto di collegamento 3-bipol. giallo	Afsluitklem 3- polig geel	Borne de conexión 3- polos amarillo
23	Connector 3-pole PS grey	Borne de connexion 3 pôles ps gris	Morsetto di collegamento 3-pol.PS grigio	Aansluitklem 3-polig PS grijs	Connector 3-pole PS grey
24	Connector 3-pole PZ violett	Borne de connexion 3 pôles violet	Morsetto di collegamento - pol.PZ violett	Aansluitklem 3-polig PZ violet	Connector 3-pole PZ violett
26	Connector 3-pole PH green	Borne de connexion 3- pôles PH vert	Morsetto di collegamento 3-pol. PH verde	Afsluitklem 3-polig PH groen	Connector 3-pole PH green
27	Connector 2-polig WA maygreen	Borne de connexion verte 2 pôles WA	Morsetto di collegamento2-bipol WA verde	Afsluitklem 2-polig WA groen	Borne de conexión 2-polos WA verde
28	Connector 2- pin blue	Borne de connexion 2 pôles R5 bleu	Morsetto di collegamento 2-bipolare blu	Aansluitconnector 2-polig blauw	Borne de conexión 2-polos azul
29	Connector 2-pole grey FW	Borne de connexion 2 pôles gris FW	Morsetto di collegame.2-bipol. grigio FW	Afsluitklem 2- polig grijs FW	Borne de conexión 2-polos grey FW
30	Connect. term. 2-polig red	Fiche rouge 2 pôles	Morsetto di collegamento2-bipolare rosso	Afsluitklem 2-polig rood	Borne de conexión 2-polos rojo
31	Connector 2-pole orange RC	Borne de connexion 2 pôles orange RC	Morsetto di collegamento2-pol arancio RC	Connector 2-polig oranje RC	Conector 2-polos naranja RC
32	Connector 2-pole white	Borne de connexion 2 pôles blanc	Morsetto di collegamento2-pol bianco	Connector 2-polig wit	Connector 2-pole blanco
35	Strain relief (10x)	Serre-câble (10x)	Ferma cavo (10x)	Trekontlasting (10x)	Retendor de cable (10x)
36	casing base plate white	Carter Socle blanc	Involucro Basamento bianco	Behuizing Bodemplaat wit	Carcasa base blanca
37	Outdoor temperature sensor	Sonde de température extérieure	Sonda temperatua esterna	Buitentemperatuursensor	Sensor de temperatura exterior

Gerätetypen Types of appliances		Types de chaudières Tipo apparecchi	Toesteltypen Tipos de aplicaciones
Gerät Appliance Chaudière Apparecchio Toestel Aparato		Land Country Pays Paese Land Paese	Bemerkungen Remarks Remarques Osservazioni Opmerkingen Observaciones
KBR 120-3 A 23	8 718 577 229	AT,DE,LU	
KBR 160-3 A 23	8 718 577 230	AT,DE,LU	
KBR 200-3 A 23	8 718 577 231	AT,DE,LU	
KBR 240-3 A 23	8 718 577 232	AT,DE,LU	
KBR 280-3 A 23	8 718 577 233	AT,DE,LU	
KBR 120-3 A 23	7 736 614 176	BE	
KBR 120-3 A 23	8 718 577 229 962	BE	
KBR 160-3 A 23	7 736 614 177	BE	
KBR 160-3 A 23	8 718 577 230 962	BE	
KBR 200-3 A 23	8 718 577 231 962	BE	
KBR 200-3 A 23	7 736 614 178	BE	
KBR 240-3 A 23	8 718 577 232 962	BE	
KBR 240-3 A 23	7 736 614 179	BE	
KBR 280-3 A 23	8 718 577 233 962	BE	
KBR 280-3 A 23	7 736 614 180	BE	
KBR 120-3 A 23	7 736 614 196	CH	
KBR 120-3 A 23	8 718 577 229 972	CH	
KBR 160-3 A 23	7 736 614 197	CH	
KBR 160-3 A 23	8 718 577 230 972	CH	
KBR 200-3 A 23	8 718 577 231 972	CH	
KBR 200-3 A 23	7 736 614 198	CH	
KBR 240-3 A 23	8 718 577 232 972	CH	
KBR 240-3 A 23	7 736 614 199	CH	
KBR 280-3 A 23	8 718 577 233 972	CH	
KBR 280-3 A 23	7 736 614 200	CH	
KBR 120-3 A 21	8 718 577 285	DE	
KBR 160-3 A 21	8 718 577 286	DE	
KBR 200-3 A 21	8 718 577 287	DE	
KBR 240-3 A 21	8 718 577 288	DE	
KBR 280-3 A 21	8 718 577 289	DE	
KBR 120-3 A 23	7 736 614 191	EE,LT,LV	
KBR 120-3 A 23	8 718 577 229 985	EE,LT,LV	
KBR 160-3 A 23	7 736 614 192	EE,LT,LV	
KBR 160-3 A 23	8 718 577 230 985	EE,LT,LV	
KBR 200-3 A 23	7 736 614 193	EE,LT,LV	
KBR 200-3 A 23	8 718 577 231 985	EE,LT,LV	
KBR 240-3 A 23	7 736 614 194	EE,LT,LV	

Gerätetypen Types of appliances		Types de chaudières Tipo apparecchi		Toesteltypes Tipos de aplicaciones	
Gerät Appliance Chaudière Apparecchio Toestel Aparato		Land Country Pays Paese Land Paese		Bemerkungen Remarks Remarques Osservazioni Opmerkingen Observaciones	
KBR 240-3 A 23	8 718 577 232 985	EE,LT,LV			
KBR 280-3 A 23	7 736 614 195	EE,LT,LV			
KBR 280-3 A 23	8 718 577 233 985	EE,LT,LV			
KBR 120-3 A 23	7 736 614 186	IT			
KBR 120-3 A 23	8 718 577 229 964	IT			
KBR 160-3 A 23	7 736 614 187	IT			
KBR 160-3 A 23	8 718 577 230 964	IT			
KBR 200-3 A 23	8 718 577 231 964	IT			
KBR 200-3 A 23	7 736 614 188	IT			
KBR 240-3	8 718 577 232 964	IT			
KBR 240-3 A 23	7 736 614 189	IT			
KBR 280-3 A 23	7 736 614 190	IT			
KBR 280-3 A 23	8 718 577 233 964	IT			
KBR 120-3 A 23	8 718 577 229 983	PL			
KBR 120-3 A 23	7 736 614 181	PL			
KBR 160-3 A 23	7 736 614 182	PL			
KBR 160-3 A 23	8 718 577 230 983	PL			
KBR 200-3 A 23	8 718 577 231 983	PL			
KBR 200-3 A 23	7 736 614 183	PL			
KBR 240-3 A 23	8 718 577 232 983	PL			
KBR 240-3 A 23	7 736 614 184	PL			
KBR 280-3 A 23	7 736 614 185	PL			
KBR 280-3 A 23	8 718 577 233 983	PL			



Bosch Thermotechnik GmbH
Junkersstr. 20-24
D-73249 Wernau / Germany