

# Olio Condens 8000 F 19 | 27

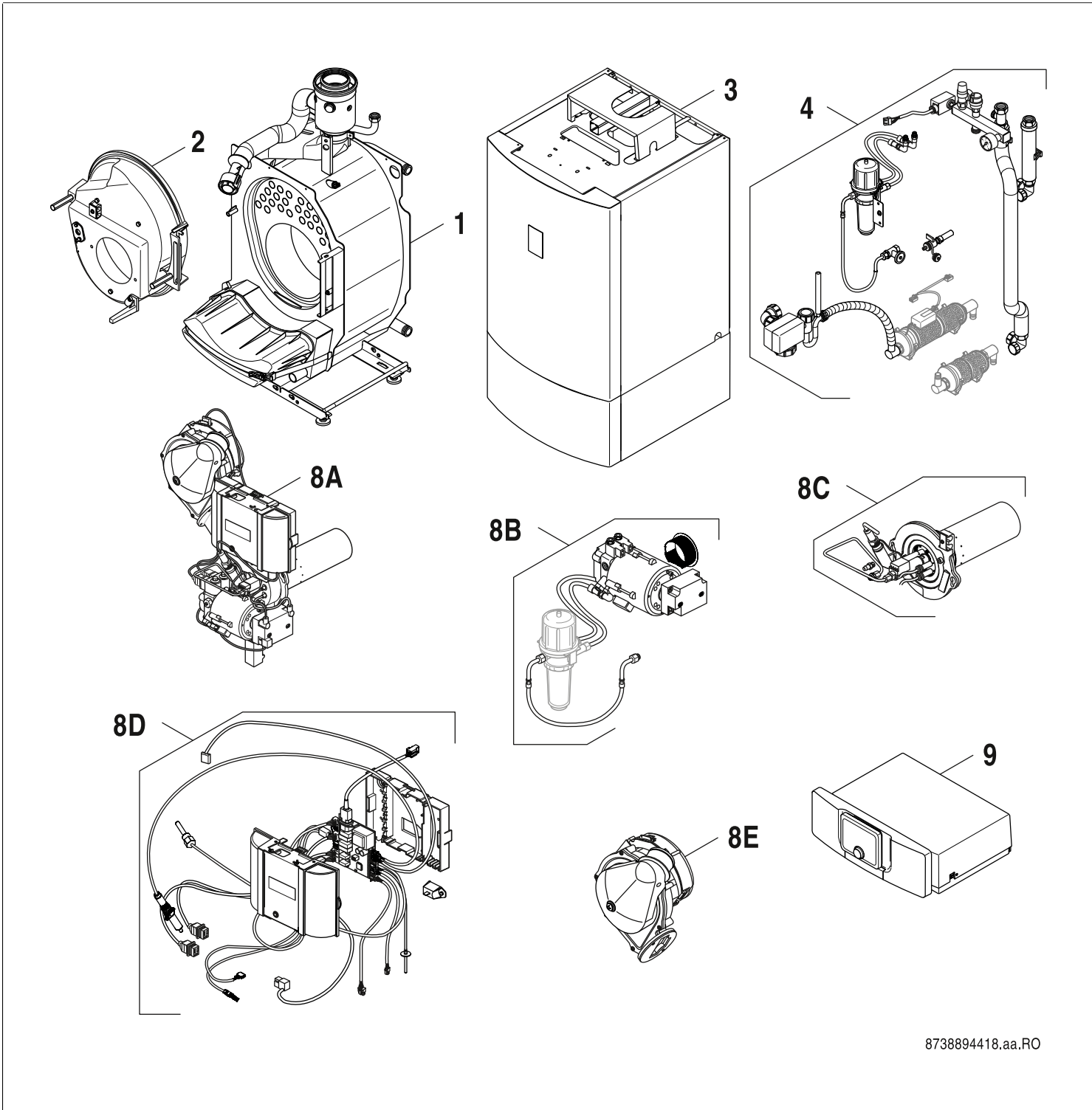

8738894418.aa.RO



**[de] Wichtige Hinweise zur Installation/Montage**

Die Installation/Montage muss durch eine für die Arbeiten zugelassene Fachkraft unter Beachtung der geltenden Vorschriften erfolgen.

**[en] Important notes on installation/assembly**

The installation/assembly must be carried out by a qualified contractor, following these instructions and in compliance with the applicable regulations.

**[fr] Instructions importantes pour l'installation/le montage**

L'installation/le montage doit être effectué(e) par un spécialiste qualifié pour les opérations concernées et dans le respect de la présente notice et des prescriptions applicables.

**[bg] Важни указания във връзка с инсталацията/монтажа**

Инсталацията/монтажът трябва да се извършва от лицензиран за работите специалист в съответствие с настоящото ръководство и с приложимите разпоредби.

**[cs] Důležité pokyny k instalaci/montáži**

Instalaci/montáž musí při dodržení pokynů uvedených v tomto návodu a platných předpisů provést odborný pracovník s příslušným oprávněním pro tyto práce.

**[da] Vigtige anvisninger til installationen/monteringen**

Installationen/monteringen skal foretages af en godkendt installatør under overholdelse af denne vejledning og de gældende forskrifter.

**[el] Σημαντικές υποδείξεις για την εγκατάσταση/συναρμολόγηση**

Η εγκατάσταση/τοποθέτηση πρέπει να ανατίθεται σε εκπαιδευμένο για τις συγκεκριμένες εργασίες τεχνικό προσωπικό με τήρηση αυτών των οδηγιών καθώς και των σχετικών προδιαγραφών.

**[es] Indicaciones importantes para instalación/montaje**

La instalación/el montaje debe realizarla personal especializado que esté autorizado para realizar estos trabajos y que tenga en cuenta estas instrucciones y la normativa vigente.

**[et] Olulised juhised paigaldamiseks/montaažiks**

Paigaldamist/montaaži tohib läbi viia vaid selleks volitusi omav spetsialist, arvestades kehtivaid nõudeid.

**[nl-BE] Belangrijke aanwijzingen betreffende de installatie/montage**

De installatie/montage moet worden uitgevoerd door een voor de werkzaamheden geautoriseerde installateur rekening houdend met deze handleiding en de geldende voorschriften.

**[fi] Tärkeitä asennus- ja kokoonpano-ohjeita**

Näihin töihin hyväksytyin ammattiasentajan pitää suorittaa asennus- ja kokoonpanotyöt voimassa olevien määräysten mukaisesti.

**[hu] Fontos tudnivalók az installálásához/szereléshez**

A telepítést/szerelést egy, a munkálatokra felhatalmazott szakembernek kell végeznie, jelen utasítás és az érvényes előírások figyelembevételével.

**[it] Avvertenze importanti per l'installazione/il montaggio**

L'installazione/il montaggio deve aver luogo ad opera di una ditta specializzata ed autorizzata in osservanza di queste istruzioni e delle direttive vigenti.

**[ka] მნიშვნელოვანი მითითებები ინსტალაციისთვის/მონტაჟისთვის**

ინსტალაცია/მონტაჟი უნდა განხორციელდეს საშუალებისთვის დამკვეთი კვალიფიციური პერსონალის მიერ, მოქმედი განაწესის დაცვით.

**[lt] Svarbios instaliavimo ir (arba) montavimo nuorodos**

Instaliavimo / montavimo darbus, laikydamiės šios instrukcijos reikalavimų ir galiojančių taisyklių, privalo atlikti šioms darbams įgalioti specialistai.

**[lv] Svarīgi norādījumi par iekārtas uzstādīšanu / montāžu**

Uzstādīšanu/montāžu jāveic atbilstošajiem darbiem sertificētam speciālistam, ievērojot šo instrukciju un spēkā esošos noteikumus.

**[nl] Belangrijke aanwijzingen betreffende de installatie/montage**

De installatie/montage moet door een erkend installateur volgens de geldende voorschriften worden uitgevoerd.

**[no] Viktig informasjon om installasjon/montering**

Installasjonen/monteringen skal gjennomføres av autoriserte installatører, og installasjonsanvisningen samt gjeldende forskrifter skal følges.

**[pl] Ważne wskazówki dotyczące instalacji/montażu**

Instalację/montaż powinien wykonać specjalista uprawniony do tego typu prac z uwzględnieniem informacji podanych w niniejszej instrukcji oraz aktualnie obowiązujących przepisów.

**[pt] Indicações importantes relativas à instalação/montagem**

A instalação/montagem deve ser efectuada por um técnico autorizado para os trabalhos, respeitando este manual e as prescrições válidas.

**[ro] Indicații importante privind instalarea/montajul**

Instalarea/montajul trebuie realizate de către un specialist autorizat pentru lucrările respective, respectându-se prezentele instrucțiuni și prescripțiile valabile.

**[ru] Важные указания по подключению/монтажу**

Подключение/монтаж должны выполнять только специалисты, имеющие допуск к выполнению таких работ, при соблюдении требований этой инструкции и действующих норм и правил.

**[sk] Dôležité pokyny týkajúce sa inštalácie/montáže**

Inštaláciu/montáž musí vykonať odborný personál, ktorý má oprávnenie pre výkon týchto prác, pričom musí dodržiavať pokyny uvedené v tomto návode a platné predpisy.

**[sl] Pomembni napotki za namestitvev/montažo**

Inštalacijo/montažo lahko izvede samo pooblaščen strokovnjak ob upoštevanju teh navodil in veljavnih predpisov.

**[sr] Važna uputstva za ugradnju i montažu**

Ovu instalaciju/montažu moraju da obave stručna lica koja su ovlašćena za obavljanje takvih radova u skladu sa ovim uputstvom i važećim propisima.

**[sv] Viktiga anvisningar för installation/montering**

Installationen/monteringen måste utföras av en behörig och tekniskt utbildad person enligt denna anvisning samt gällande föreskrifter.

**[tr] Kurulum/Montaj ile ilgili önemli uyarılar**

Kurulum/montaj, bu çalışmalarını yapmasına müsaade edilen uzman kişiler tarafından işbu kılavuz ve geçerli yönetmelikler dikkate alınarak yapılmalıdır.

**[uk] Важливі вказівки щодо установки/монтажу**

Встановлення/монтаж повинні виконувати фахівці, що допущені до виконання таких робіт, із дотриманням цієї інструкції та діючих приписів.

**[zh] 安装方面的重要提示**

安装和组装工作必须由经过许可的专业人员进行，同时必须遵守本说明书和现行法规的相关要求

**[ar] ملاحظات هامة للتركيب/التجميع**  
يجب أن يتم التركيب/التجميع من قبل متخصص مصرح له بالعمل، مع مراعاة اللوائح السارية.

**[fa] تذکرات مهم درباره نصب/مونتاژ**  
نصب/مونتاژ باید توسط فردی حرفه ای که مجاز به انجام این کار است، و همچنین با توجه کامل به مقررات مربوطه انجام شود.

**[az] Quraşdırılma**

Quraşdırılma işinin yerinə yetirilməsi səlahiyyətli bir mütəxəssis tərəfindən və müvafiq qaydalara uyğun olaraq aparılmalıdır.

**Ersatzteilliste**  
**Spare parts list**

**Liste des pièces de rechange**  
**Lista parti di ricambio**

**Onderdelenlijst**  
**Lista de repuestos**

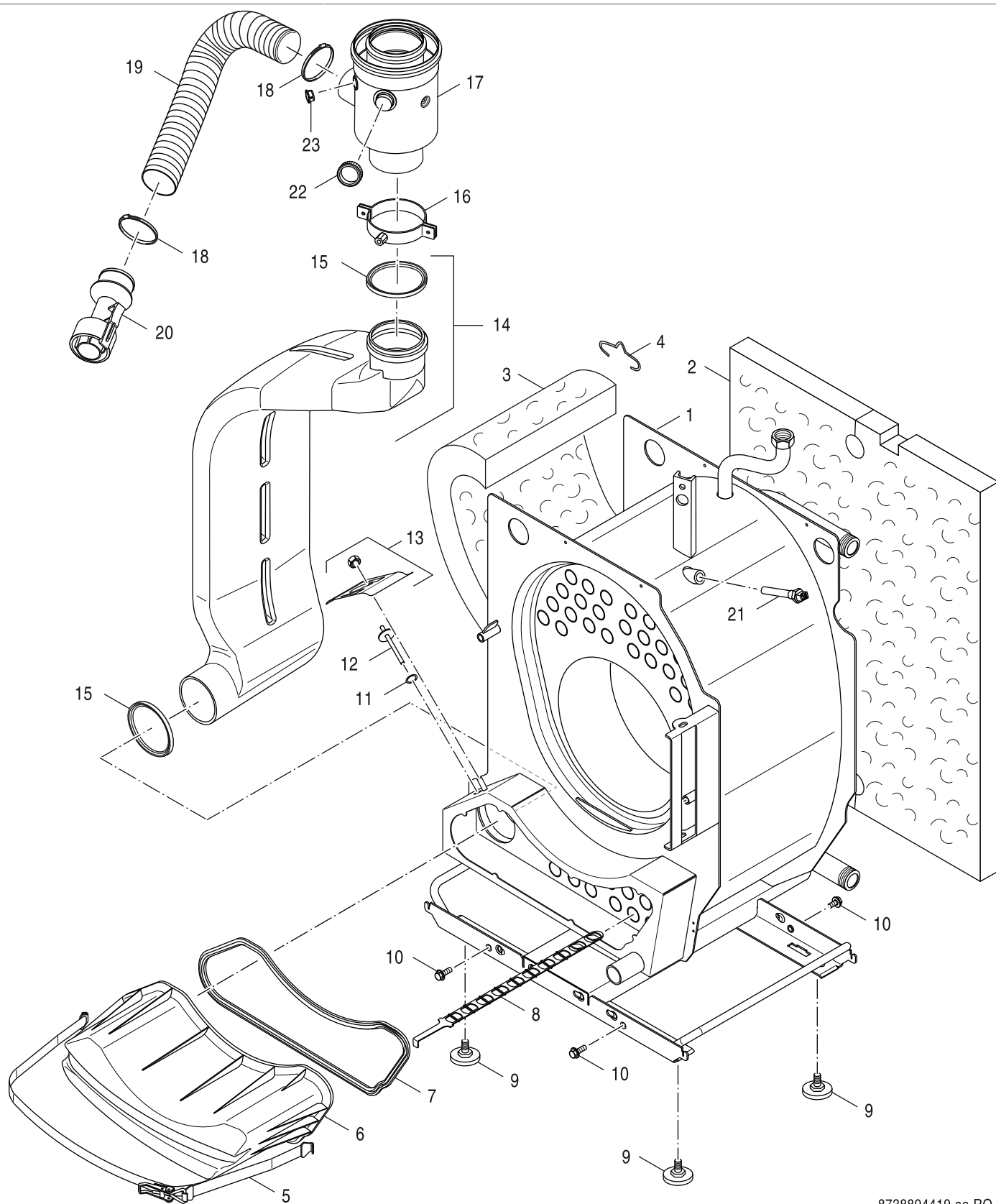

8738894419.aa.RO

**1**

Kesselblock OC 8000F 19/27  
Boiler block OC 8000F 19/27  
Corps de chauffe OC 8000F 19/27  
Corpo caldaia OC 8000F 19/27  
Ketelblok OC 8000F 19/27  
Cuerpo de caldera OC 8000F 19/27

**Olio Condens 8000 F 19 | 27**



**Ersatzteilliste**  
**Spare parts list**

**Liste des pièces de rechange**  
**Lista parti di ricambio**

**Onderdelenlijst**  
**Lista de repuestos**

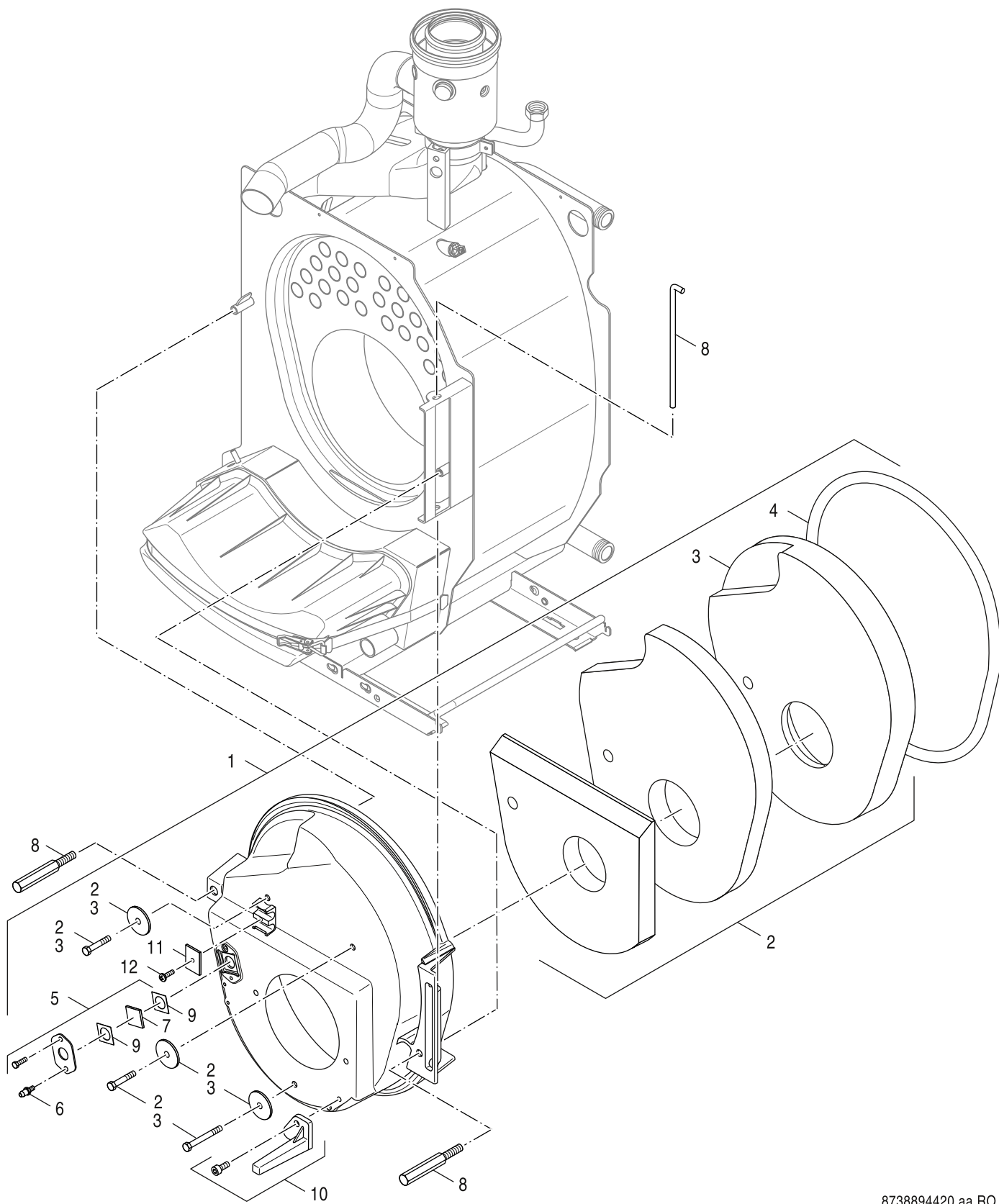

8738894420.aa.RO

**Olio Condens 8000 F 19 | 27**

**2**

- Brennertür OC 8000F 19/27
- Burner door OC 8000F 19/27
- Porte de brûleur OC 8000F 19/27
- Porta del bruciatore OC 8000F 19/27
- Branderdeur OC 8000F 19/27
- Puerta del quemador OC 8000F 19/27



**Ersatzteilliste**  
**Spare parts list**

**Liste des pièces de rechange**  
**Lista parti di ricambio**

**Onderdelenlijst**  
**Lista de repuestos**

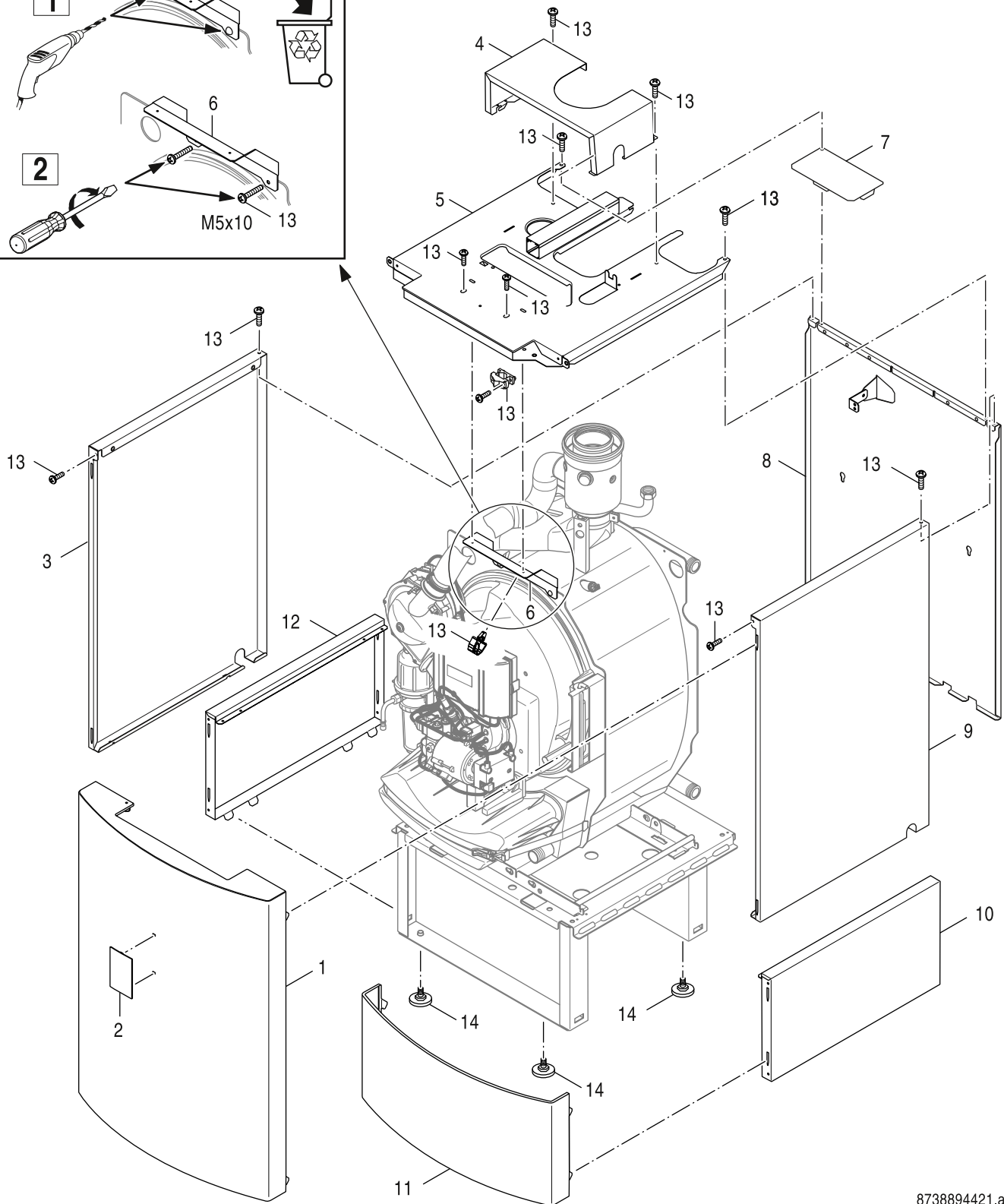
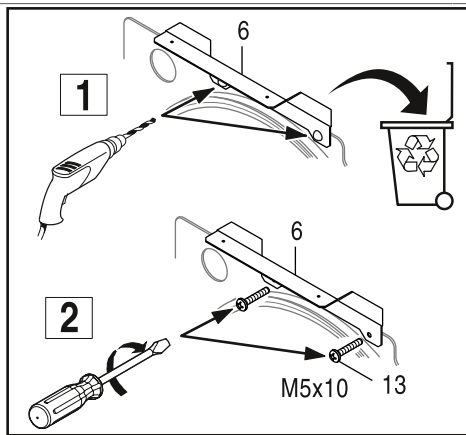

8738894421.aa.RO

**3**

Verkleidung OC 8000F 19/27  
Casing OC 8000F 19/27  
Carénage OC 8000F 19/27  
Rivestimento OC 8000F 19/27  
Bekleding OC 8000F 19/27  
Revestimiento OC 8000F 19/27

**Olio Condens 8000 F 19 | 27**



**Ersatzteilliste**  
**Spare parts list**

**Liste des pièces de rechange**  
**Lista parti di ricambio**

**Onderdelenlijst**  
**Lista de repuestos**

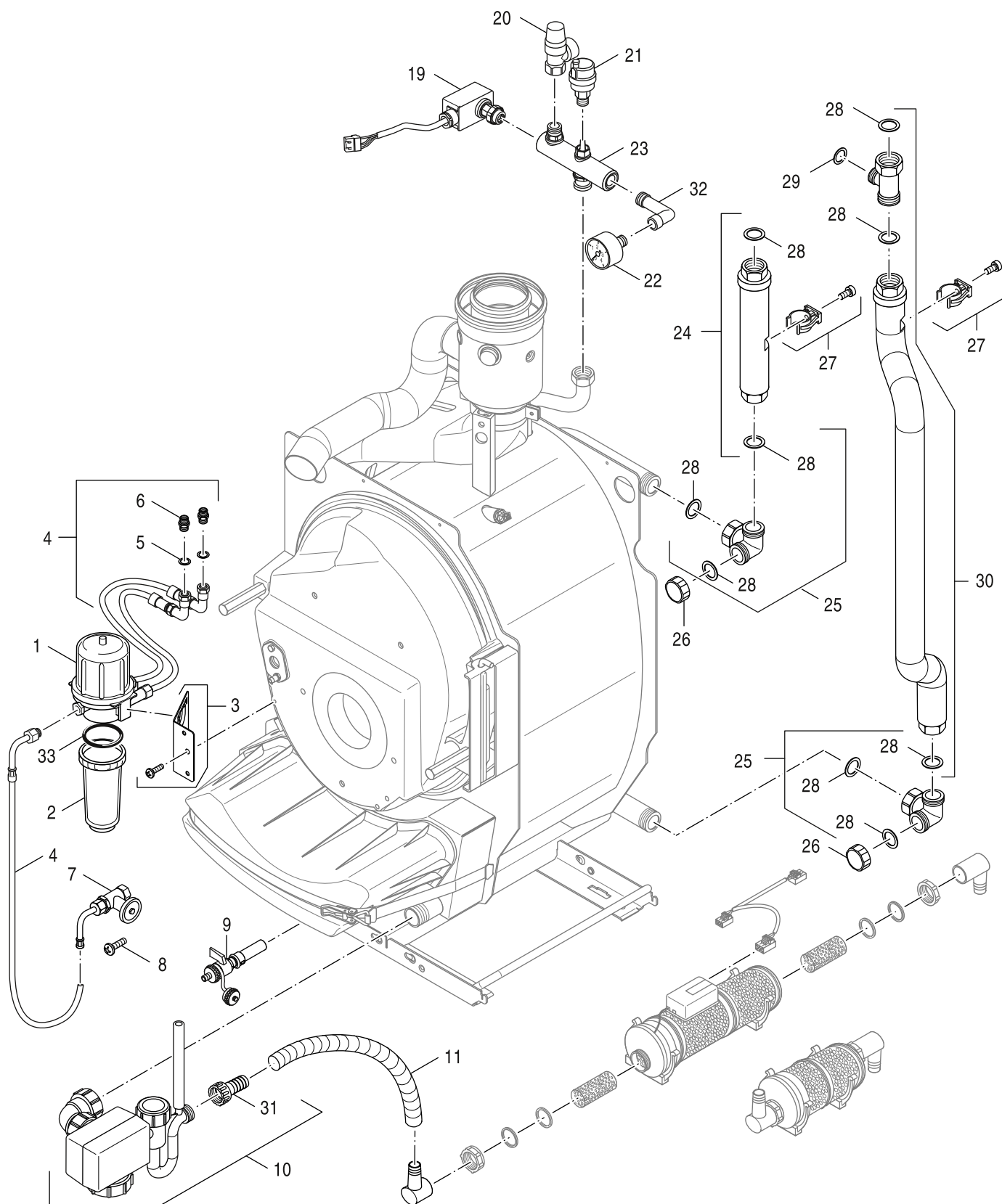

8738894422.ab.RO

4  
 Armatur OC 8000F 19/27  
 Valve OC 8000F 19/27  
 Robinet OC 8000F 19/27  
 Valvola OC 8000F 19/27  
 Armatuur OC 8000F 19/27  
 Valvulería OC 8000F 19/27

**Olio Condens 8000 F 19 | 27**



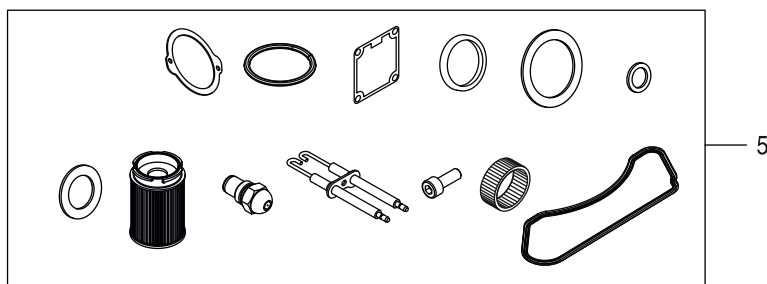
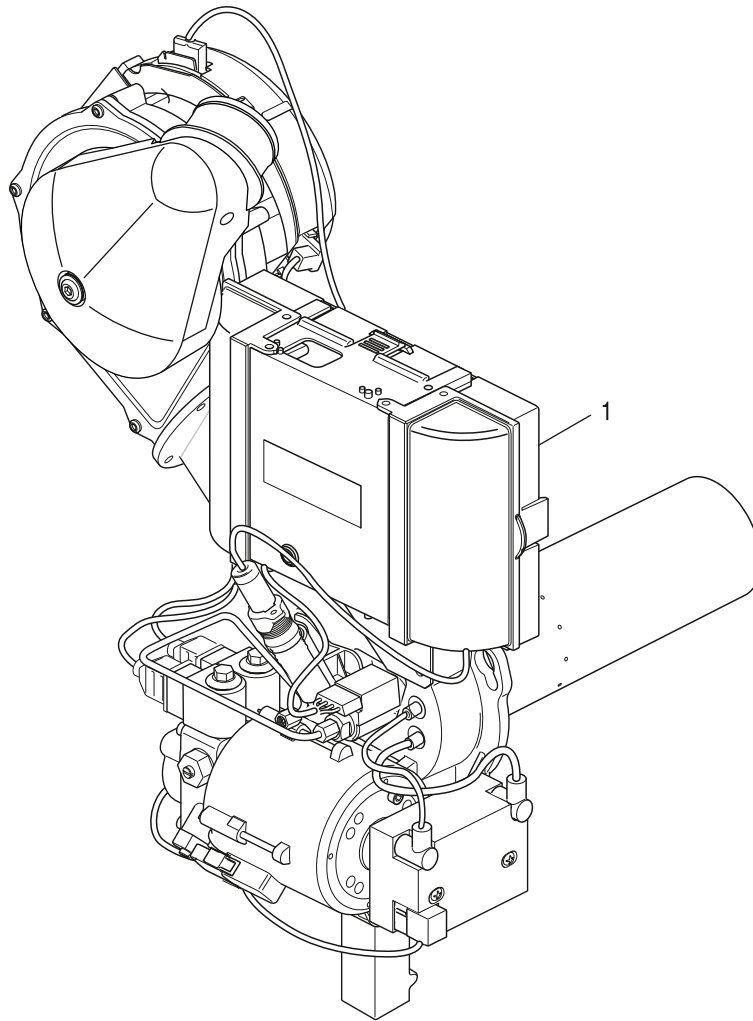

6720905123.ab.RS-Brennervarianten

**8A**  
Brennervarianten  
Burner versions  
Variantes de brûleur  
Varianti bruciatore  
Brandervarianten  
Variantes de quemadores

**Olio Condens 8000 F 19 | 27**



Ersatzteilliste  
Spare parts list

Liste des pièces de rechange  
Lista parti di ricambio

Onderdelenlijst  
Lista de repuestos

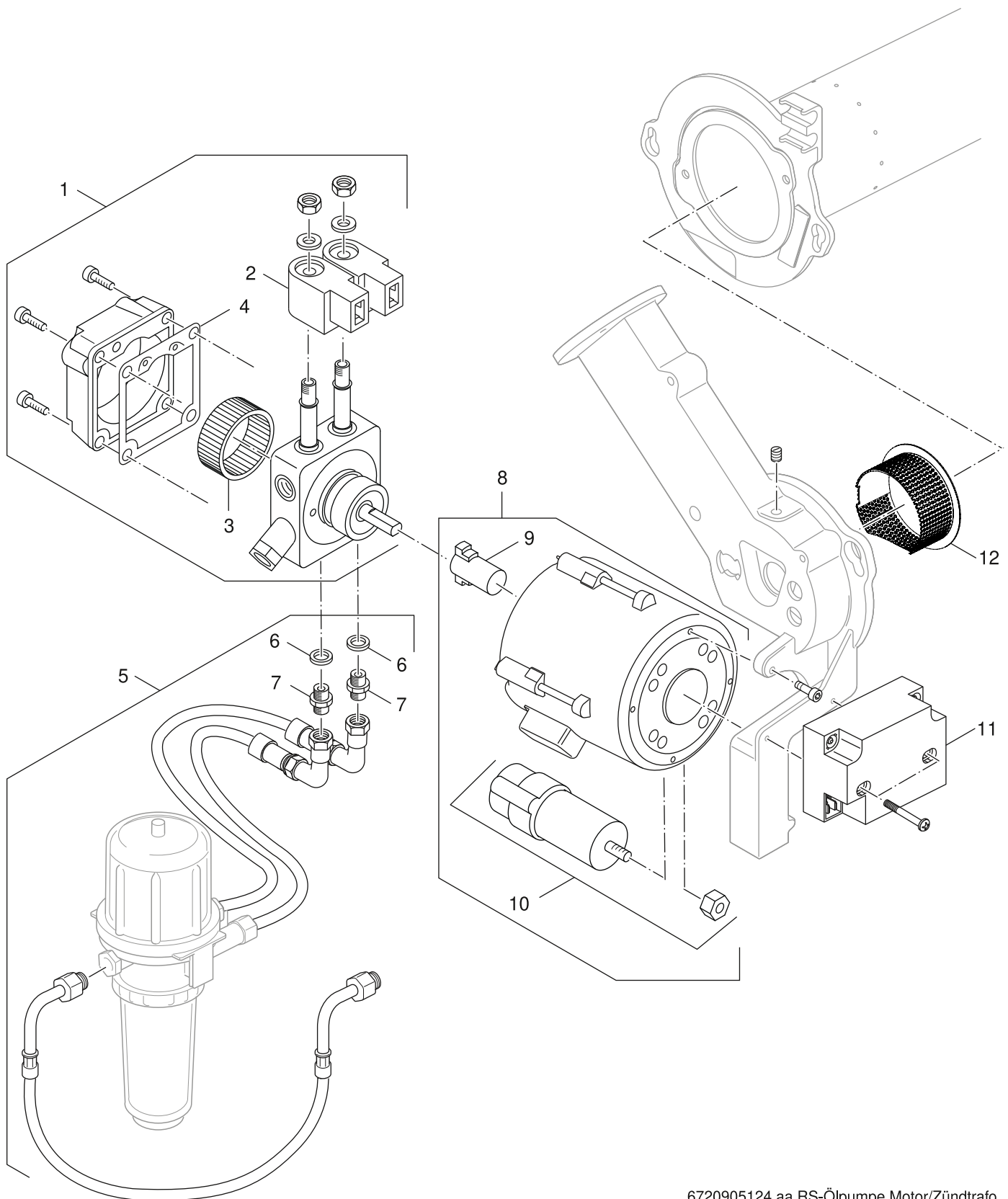

6720905124.aa.RS-Ölpumpe Motor/Zündtrafo

**8B**

Ölpumpe  
Oil pump  
Pompe à fioul  
Pompa olio  
Oliepomp  
Bomba de aceite

**Olio Condens 8000 F 19 | 27**



**Ersatzteilliste**  
Spare parts list

**Liste des pièces de rechange**  
Lista parti di ricambio

**Onderdelenlijst**  
Lista de repuestos

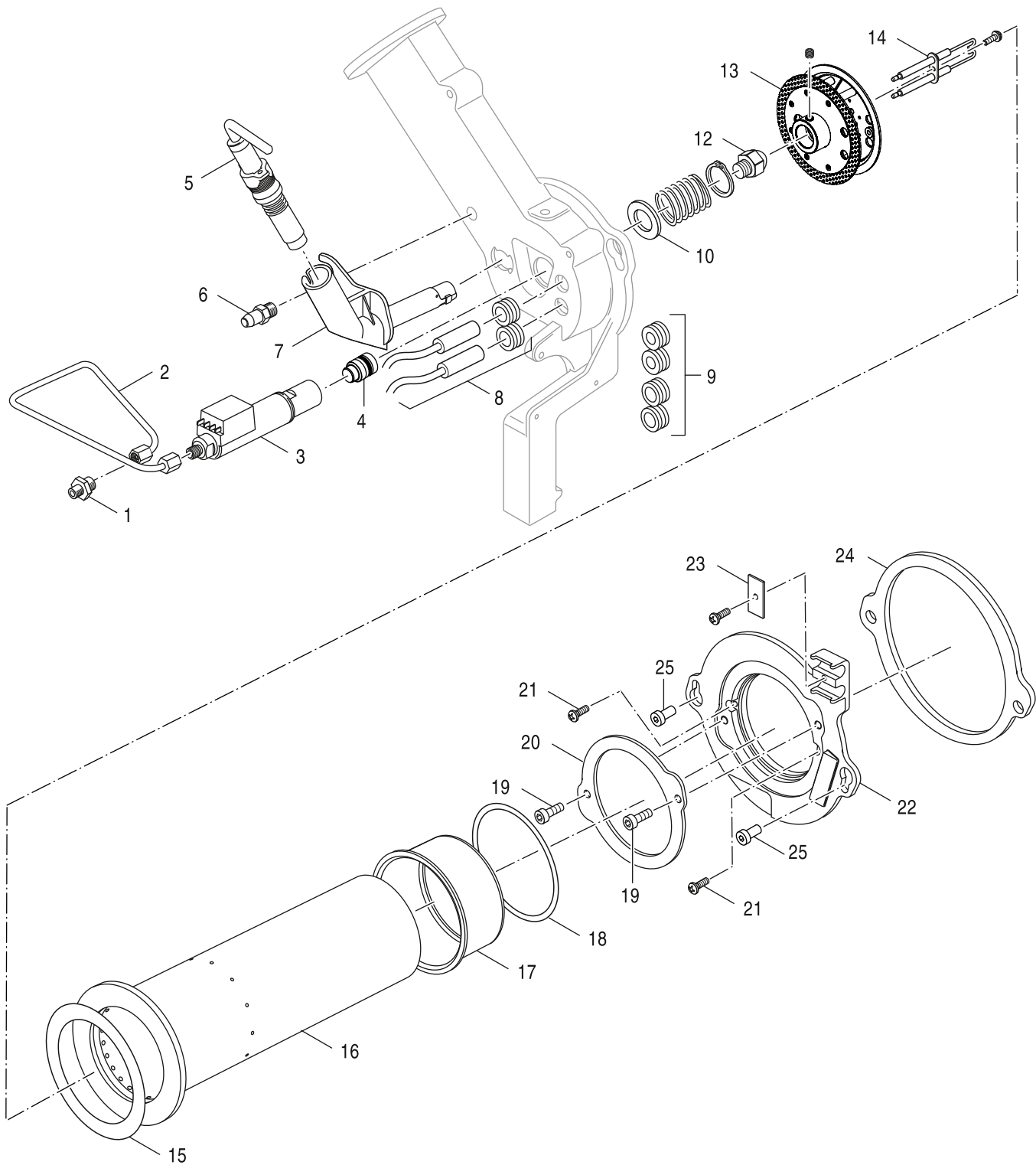

6720905125.ac.RS-Mischsystem Ivorw rmer/Brennerrohr

**8C**

Brennerrohr  
Burner tube  
Tube de combustion  
Raccordo bruciatore  
Brander pijp  
Tubo mezclador

**Olío Condens 8000 F 19 | 27**



**Ersatzteilliste**  
Spare parts list

**Liste des pièces de rechange**  
Lista parti di ricambio

**Onderdelenlijst**  
Lista de repuestos

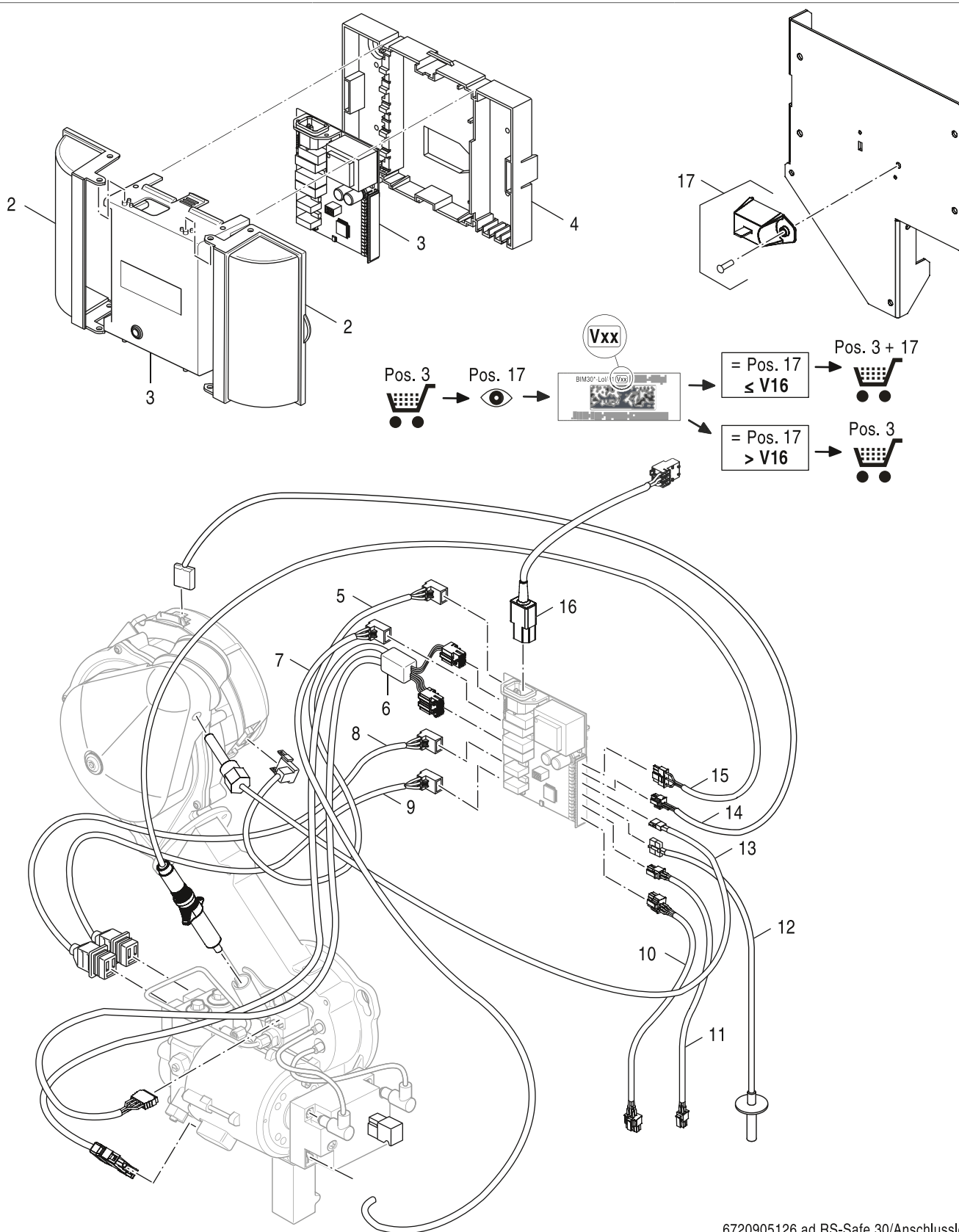

6720905126.ad.RS-Safe 30/Anschlussleitung

**8D**

SAFe  
SAFe  
SAFe  
SAFe  
SAFe

**Ollo Condens 8000 F 19 | 27**



Ersatzteilliste  
Spare parts list

Liste des pièces de rechange  
Lista parti di ricambio

Onderdelenlijst  
Lista de repuestos

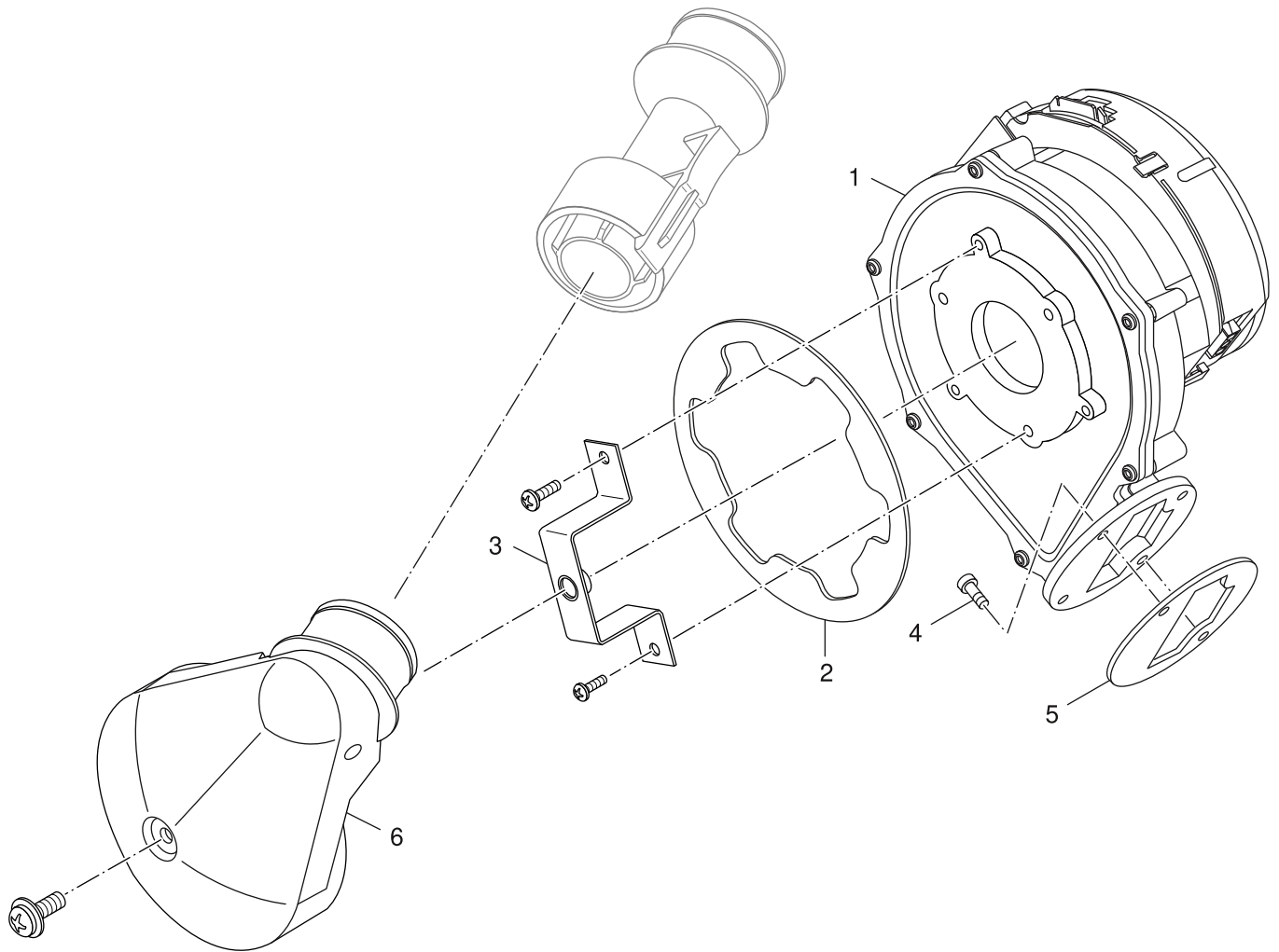

6720905127.aa.RS-Gebläse

**8E**

Gebläse  
Centrifugal blower  
Ventilateur  
Ventilatore  
Ventilador  
Ventilador

**Olio Condens 8000 F 19 | 27**



Ersatzteilliste  
Spare parts list

Liste des pièces de rechange  
Lista parti di ricambio

Onderdelenlijst  
Lista de repuestos

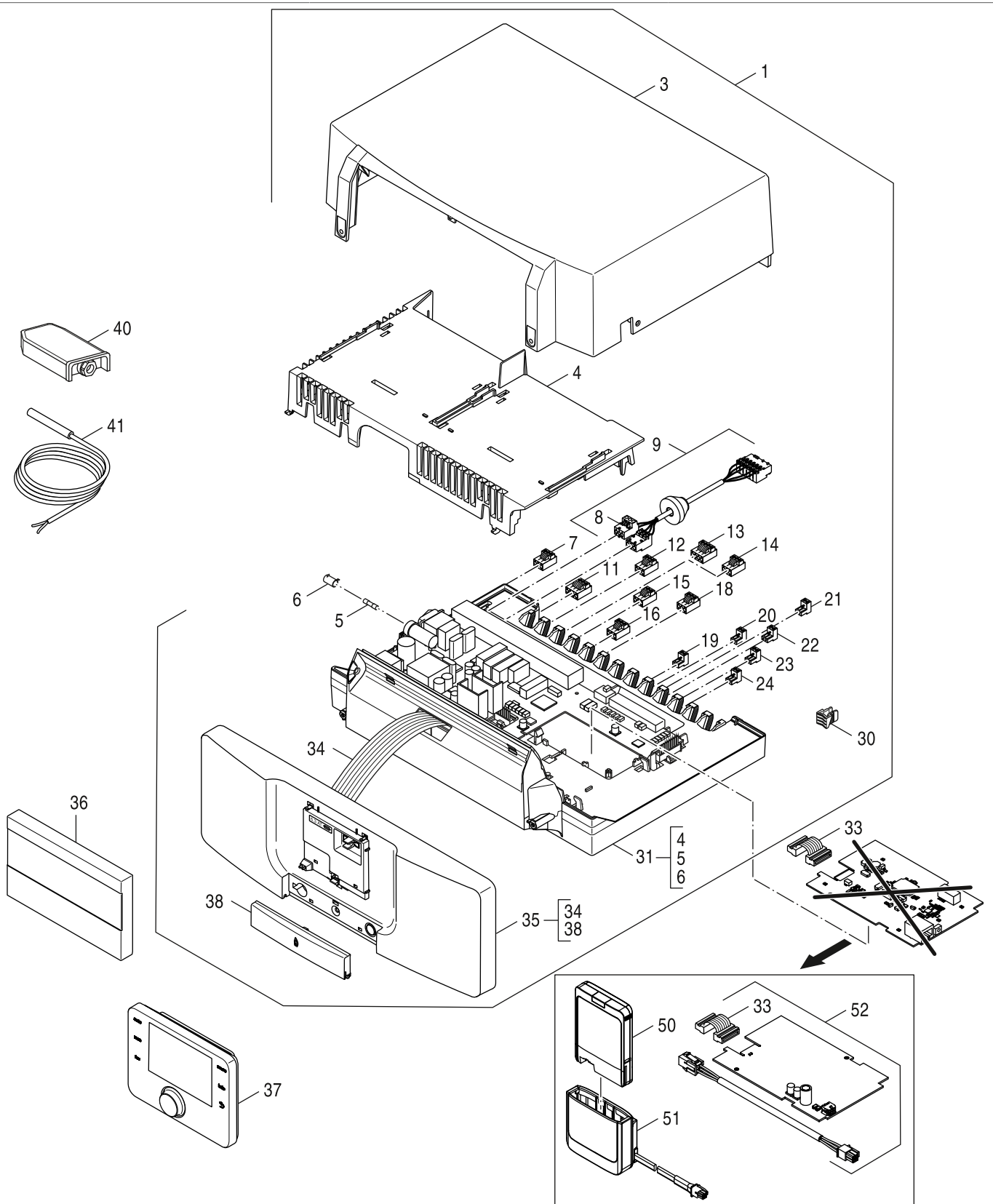

8738892988.ad.RO

9

MX25i  
MX25i  
MX25i  
MX25i  
MX25i

Olio Condens 8000 F 19 | 27



<b>Übersetzungsliste</b> <b>List of translations</b>		<b>Liste des traductions</b> <b>Traduzione delle descrizioni</b>		<b>Vertalinglijst</b> <b>Lista de traducciones</b>	
Pos	Description	Denomination	Descrizione	Benaming	Descripción
<b>1</b>	<b>Element of construction</b>	<b>Groupe de construction</b>	<b>Gruppo di costruzione</b>	<b>Montagegroep</b>	<b>Grupo de construcción</b>
1	Boiler Body 19kW V3	Corps de chauffe 19kW V3	Corpo caldaia 19kW V3	Ketelblok 19kW V3	Cuerpo de caldera 19kW V3
1	Boiler Body 27kW V3	Corpsde chauffe 27kW V3	Corpo caldaia 27kW V3	Ketelblok 27kW V3	Cuerpo de caldera 27kW V3
2	HEAT INSULATION RR PANEL	Isolation Dossieret	Isolamento Parete posteriore	Isolatie Achterwand	Aislamiento pared trasera
3	insulation boiler block 19/27KW	Isolation Corps de chauffe 19/27KW	Isolamento Corpo caldaia 19/27KW	Isolatie ketelblok 19/27KW	Aislamiento cuerpo de caldera 19/27KW
4	Insulation Clamp (10x)	Ressorts de retenue d 0.8 (10x)	Molla di tenuta (10x)	Borgveer (10x)	Muelle tensor para aislamientos (10x)
5	Fixing strap silencer V3	Bande de serrage Silencieux V3	Nastro tensore Silenziatore V3	Fixeerband Geruisdemper V3	Cinta de tensión silenciador de chimenea
6	Silencer compl	Silencieux	Silenziatore	Geruisdemper	Silenciador de chimenea
7	Sealing silencer (1x)	Joint Silencieux (1x)	Guarnizione Silenziatore (1x)	Pakking Geruisdemper (1x)	Junta silenciador de chimenea (1x)
8	Turbolator SB105 V2	Turbulateur SB105 V2	Turbolatore SB105 V2	Turbulator SB105 V2	Turbulador SB105 V2
9	Foot M10x51 (4x)	Pieds réglables M10x51 (4x)	Piedini regolabili M10x51 (4x)	Voetjes Boiler HP-270-1	Patas regulables M10x51 (4x)
10	Inst-mat boiler base frame oil BW -27kW	Matériel de montage Socle de la chaudi#r	Materiale per il mont. Sottofondo caldai	Montagemateriaal Ketelsokkel -27kW	Material de montaje Base de la caldera
11	O-ring 6x2 ISO 3601 FKM (3pc)	Joint torique 6x2 ISO 3601 FKM (3x)	O-ring 6x2 ISO 3601 FKM (3x)	O-Ring 6x2 ISO 3601 FKM voor (3x)	Anillo tórico 6x2 ISO 3601 FKM (3x)
12	Gas sensor D29/d6 60mm	Sonde de temperature de fumee 60mm	Sonda gas combusti D29/d6 60 lung.	Rookgasvoeler voor D29/d6 60mm	Sonda de gases para GB125 D29/d6 60mm
13	Holding plate exhaust sensor	Plaque de jonction	Lamierino	Houderplaat	Placa de unión
14	Exhaust pipe DN80	Tuyau d'évacuation gaz DN80	Condotta fumi DN80	Rookgasafvoerbuus DN80	Tubo salida de gases DN80
15	lips seal d80 PerOxyd (5x)	Joint a levre DN80 peroxyde (5x)	Guarniz. ad anello spigolo tenutaDN80 5x	Lippenafdichting DN80 PerOxid (5x)	Junta DN80 PerOxyd (5x)
16	Clamp D85 (1x) packed	Support D85 (1x)	Fascetta D85 (1x)	Klembeugel D85 (1x)	Abrazadera D85 (1x)
17	Boiler connection	Raccordement chaudi#re	Attacco caldaia	Ketelaansluiting	Conexión de caldera
18	Clip wire hose clip 50-57mm	Double collier de serrage de fil 50-57mm	Morsetto doppio filo 50-57mm	Dubbele kabelklem 50-57mm	Abrazadera de alambre doble 50-57mm
19	Hose DN52 L800mm	Tuyau DN52 L800mm	Tubo flessibile DN52 L800mm	Flexibele slang DN52 L800 G135	manguera DN52 L800mm
20	Venturi standpipes DN52	Venturi Buse DN52	Venturi Manicotto DN52	Venturibevestiging voor G(B)135	Venturi Tubo de empalme DN52
21	Sensor boiler G1/4 75 D=11	Sonde chaud g1/4 75mm d=11mm	Sonda caldaia G1/4 75 lun. D=11mm	Ketelvoeler G1/4 75mm D=1	Sensor caldera G1/4 75mm D=11
22	Sample point cap	Capot de protection	Calotta	Beschermkap	Capuchón protector
23	Plug	Bouchon	Tappo	Stop	Tapon
<b>2</b>	<b>Element of construction</b>	<b>Groupe de construction</b>	<b>Gruppo di costruzione</b>	<b>Montagegroep</b>	<b>Grupo de construcción</b>
1	Burner door assy (cast iron)	Porte de br#leur	Porta del bruciatore	Branderdeur	Puerta del quemador
2	Thermal insulation Burner door V2	Isolation Porte de br#leur V2	Isolamento Porta del bruciatore V2	Isolatie brander deur V2	Aislamiento Puerta del quemador V2
3	Thermal insulation Burner door	Isolation Porte de br#leur	Isolamento Porta del bruciatore	Isolatie brander deur	Aislamiento Puerta del quemador
4	Rope seal 18x1408 GP	Cordon d'étanchéité 18x1408 ,GP	Cordone ermetizzante 18x1408 ,GP	Afdichtingkoord 18x1408 ,GP	Cordón junta 18x1408 ,GP
5	Viewing hole lock V3 compl.	Viseur flam v3	Chiusura spioncino V3 compl.	Kijkdeksel V3	Mirilla completa V3
6	Measuring nozz M6 SW10 V2	Injecteur de mesure de press. M6 SW10 V2	Ugello misura della pressione M6 SW10 V2	Drukmeetnippel M6	Toma presiones M6 SW10 V2

Übersetzungsliste List of translations		Liste des traductions Traduzione delle descrizioni		Vertalinglijst Lista de traducciones	
Pos	Description	Denomination	Descrizione	Benaming	Descripción
7	Glass pane 30x30x3,3mm repl pack	Verre tempax 30x30x3,3mm v2	Lastra di vetro 30x30x3,3mm	Glasvenster 30x30x3,3mm	Mirilla 30x30x3,3mm
8	Installation material burner door	Matériel de montage Porte de br#leur	Materiale per il montaggio Porta del bru	Montagemateriaal branderdeur	Material de montaje Puerta del quemador
9	Gasket 30x30x3mm	Joint 30x30x3 (G315)	Guarnizione 30x30x3	Pakking 30x30x3	Junta 30x30x3
10	Support service position	Support service position	Supporto servizio posizione	Steun	Soporte Servicio posición
11	Mounting plate oil hose	Plaque de jonction Flexible fioul	Lamierino Tubo gasolio	Vangschaal Oliebuis	Placa de unión Tubo flexible de aceite
12	Installation material oil burner BE	Matériel de montage Br#leur fioul BE	Materiale per il montaggio Bruciatore a	Montagemateriaal brander BE	Material de montaje quemador de gasóleo
<b>3</b>	<b>Element of construction</b>	<b>Groupe de construction</b>	<b>Gruppo di costruzione</b>	<b>Montagegroep</b>	<b>Grupo de construccion</b>
1	Cover boiler TG13/TS10	Couvercle avant Corps de chauffe TG13	Parete anteriore Corpo caldaia TG13/TS10	Voorwand ketelblok TG13/TS10	Pared delantero cuerpo de caldera TG13
2	Badge "Bosch" packed	Plaque signalétique Bosch	Targhetta caldaia Bosch	Typeplaat Bosch	Placa del aparato Bosch
3	SIDE PANEL LEFT	Paroi latérale gauche	Pannello laterale sinistra	Zijpaneel links	Parte lateral izquierda
4	Hood design	Capot Design	Coperchio design	Design Afdekkap	Carcasa design
5	Hood 590 x 558	Capot 590 x 558	Coperchio 590 x 558	Afdekkap 590 x 558	Carcasa 590 x 558
6	Cross beam top	Traverse supérieur	Traversa	Vangschaal	Mástil de refuerzo
7	Covering sheet Hood	Tôle de protection Capot	Lamierina di protezione Coperchio	Afdekplaat	Chapa de recubrimiento capota
8	Rear panel	Dosseret	Parete posteriore	Achterwand	Pared trasera
9	Side panel right	Paroi latérale droite	Pannello laterale destra	Zijpaneel rechts	Parte lateral derecha
10	SIDE WALL BASE FRAME	Paroi latérale bas	Parete laterale sotto	Zijwand Onder	Pared lateral debajo
11	Cover base frame	Couvercle avant bas	Parete anteriore sotto	Voorwand Onder	Pared delantero debajo
12	SIDE WALL BASE FRAME	Paroi latérale bas	Parete laterale sotto	Zijwand Onder	Pared lateral debajo
13	INSTALLATION MATERIAL CASING	Matériel de montage Carénage	Materiale per il montaggio Rivestimento	Montagemateriaal bekleding	Material de montaje revestimiento
14	Foot M10x51 (4x)	Pieds réglables M10x51 (4x)	Piedini regolabili M10x51 (4x)	Voetjes Boiler HP-270-1	Patas regulables M10x51 (4x)
	Boiler base frame 110mm 19/27	Socle de la chaudi#re 110mm 19/27	Sottofondo caldaia 110mm 19/27	Ketelonderbouw 110mm 19/27	Base de la caldera 110mm 19/27
	Boiler base frame 300mm 19/27	Socle de la chaudi#re 300mm 19/27	Sottofondo caldaia 300mm 19/27	Ketelonderbouw 300mm 19/27	Base de la caldera 300mm 19/27
	Accessory brush for STK 19-27	Brosse de ramonage STK 19-27	Spazzola per la pulizia STK 19-27	Reinigingsborstel STK 19-27	Cepillo de limpieza STK 19-27
	Paint pen BBT-white VZF 37351 12ml	Crayon pour retouche vernis BBT- blanc	Pennarello a vernice per ritocchi bianco	Lakstift BBT- wit 12ml	Rotulador de laca BBT- blanco 12ml
	Paint spray can BBTwhite VZF 37351 400ml	Laque gaseuse VZF 37351 400ml blanc	Erogatore VZF 37351 400ml bianco	Doosje lak VZF 37351 400ml wit	Atomizador esmalteVZF 37351 400ml blanco
<b>4</b>	<b>Element of construction</b>	<b>Groupe de construction</b>	<b>Gruppo di costruzione</b>	<b>Montagegroep</b>	<b>Grupo de construccion</b>
1	Filter oil B20 TOC-DUO A	Filtre # fioul B20 TOC-DUO A	Filtro del gasolio B20 TOC-DUO A	Oliefilter B20 TOC-DUO A	Filtro de gasóleo B20 TOC-DUO A
2	Filter Paper 5-20 Mikro incl. Seal sp	Papier-filtre 5-20 Mikro avec joint	Carta da filtro 5-20 Mikro con sigillo	Filtreerpapier 5-20 Mikro met pakking	Cartucho filtrante 5-20 Mikro con junta
3	Bracket Oil Filter TOC-DUO V	Tôle de fixation Filtre # huile	Angolare di sostegno Filtro a olio	Steenhoek Olie Filter TOC-DUO V	Angulo soporte Filtro de aceite
4	Hose set cpl yellow	Jeu de tuyau jaune	Tubetto giallo	Slangenset geel	Conjunto de tubo flexible amarillo
5	Washer 13x18x1,5 (5x)	Joint 13x18x1,5 (5x)	Guarnizione 13x18x1,5 (5x)	Dichting 18 x 13 x 1,5 (5x)	Junta toma presiones mirilla 13x18x1,5

<b>Übersetzungsliste</b> <b>List of translations</b>		<b>Liste des traductions</b> <b>Traduzione delle descrizioni</b>		<b>Vertalinglijst</b> <b>Lista de traducciones</b>	
Pos	Description	Denomination	Descrizione	Benaming	Descripción
6	Screw connection 3/8x1/4" straight	RACCORD 3/8"x1/4",DROIT	Raccordo 3/8x1/4"	Nippel 3/8"x1/4" recht vr olieflexibel	Racor 3/8 x 1/4
7	Shut-off valve G3/8"	Vanne d'arr#t G3/8"	Valvola di intercettazione G3/8"	Afsluitventiel G3/8"	Válvula de corte G3/8"
8	Screw KB50x35/20 (4Pc)	Vis KB50x35/20 (4x)	Vite KB50x35/20 (4x)	Schroef KB50x35/20 (4x)	Tornillo KB50x35/20 (4x)
9	Boiler fill & drain valve 1/2 L80 finpV2	Robinet de remplissage 1/2" avec	Rubinetto di carico 1/2" a	Vulkaan 1/2" Verlenging L80 V2	Grifo de llenado y de vaciado 1/2"
10	Siphon with float V2	Siphon kpl V2	Sifone con galleggiante V2	Sifon met vlotter V2	Sifón con flotador V2
11	Tube set DN20 DN20 (3m)	Tuyau DN20 (3m)	Tube flessibile DN20 (3m)	Slang DN20 (3m)	Manguera DN20 (3m)
19	Pressure monitor min m adapter	Pressostat compl. Min	Pressostato	Drukschakelaar G(B)135	Controlador de presión
20	Membrane safety valve MS 1/2, 3 bar	SOUPAPE DE SECURITE MS 1/2 3BAR	Valvola sicurezza MS 1/2", 3bar	Veiligheidsklep MS 1/2", 3bar	Válvula de seguridad MS 1/2", 3bar
21	Air_vent automatic purging system 3/8"	Pot de ventilateur 3/8"	Valvola di sfianto 3/8"	Ontluchtingsdeksel 3/8"	Separador de aire 3/8"
22	Pressure gauge G3/8" D50, axial 0 -4 bar	MANOMETRE G3/8" D50 0-4 BAR GB202	Manometro G3/8" D50, axial 0-4bar	Manometer 3/8" D50, 0-4 bar voor G135	Manómetro G3/8" D50, axial 0-4bar
23	Distribution safety equipment	Collecteur - groupe de sécurité	Distributore Gruppo sicurezza	Kortsluitleiding Zekerheidsgroep	Boquilla de purga grupo de seguridad
24	Flow pipe ht circ DN25 cpl.	Tube départ DN25	Tube di mandata DN25	Aanvoerleiding DN25	Tube de impulsión DN25
25	Corner distributor G1" cpl	Equerre Distributeur G1"	Angolo Distributore G1"	Hoeksteun Kortsluitleiding G1"	Ángulo Boquilla de purga G1"
26	Cover G1" packed	Capuchon G1"	Tappo G1"	Kapje G1"	Tapa G1"
27	Pipe-Clips , 1 fold 28 mm M6 (2x)	Tube-Clips 28 mm M6 (2x)	Tube-Clips 28 mm M6 (2x)	Pijp-Clips 28 mm M6 (2x)	Tube-Clips 28 mm M6 (2x)
28	Gasket D21X30X3, DVGW-ZUGEL (5x) everp	Joint D21x30x3 (5x)	Guarnizione (5x)	Pakking (5x)	Junta D21x30x3 (5x)
29	Gasket D17x24x2 AFM34 (x10)	Joint D17x24x2 AFM34 (10x)	Guarnizione D17x24x2 AFM34 (10x)	Afdichting D17x24x2 AFM34	Junta D17x24x2 AFM34 (10x)
30	Return pipe ht c DN25 kpl	Tube retour HK DN25 kpl V2	Tube di ritorno HK DN25 kpl V2	Retourleiding HK DN25 kpl V2	Tube de retorno HK DN25 kpl V2
31	Conn union 2/3 R3/4" everp	Raccord sonde sanitaire 2/3 R3/4"	Raccordo 2/3 R3/4"	Schroefkoppeling 2/3 R3/4" v.sifon SB105	Conexión 2/3 R3/4"
32	Accessory pipe elbow 3/8" IG x 1/2" AG	Coude 3/8" IG x 1/2" AG	Curva 3/8" IG x 1/2" AG	Bocht 3/8" IG x 1/2" AG	Arco 3/8" IG x 1/2" AG
33	O-Ring for Oilfilter packed	Joint torique pour filtre huile	O-ring per filtro olio	O-ring voor oliefilter	Junta tórica para el filtro
	Sealing-Set Siphon	Kit de joints pour siphon	Set guarnizioni sifone	Afdichtingsset sifon	Juego de juntas sifón
<b>8A</b>	<b>Element of construction</b>	<b>Groupe de construction</b>	<b>Gruppo di costruzione</b>	<b>Montagegroep</b>	<b>Grupo de construccion</b>
1	Burner Oil BZ 1.0-19 V2 sp	Br#leur fioul BZ 1.0-19 V2	Bruciatore a gasolio BZ 1.0-19 V2	Stookoliebrander BZ 1.0-19 V2	Quemador de gasóleo BZ 1.0-19 V2
1	Burner Oil BZ 1.0-27 V2 sp	Br#leur fioul BZ 1.0-27 V2	Bruciatore a gasolio BZ 1.0-27 V2	Stookoliebrander BZ 1.0-27 V2	Quemador de gasóleo BZ 1.0-27 V2
5	Service-Set BZ1.0-19 everp	Set de service BZ1.0-19	Imballato BZ1.0-19	Service set BZ1.0-19	Conjunto de servicio BZ1.0-19
5	Service-Set BZ1.0-27 everp	Set de service BZ1.0-27	Imballato BZ1.0-27	Service set BZ1.0-27	Conjunto de servicio BZ1.0-27
<b>8B</b>	<b>Element of construction</b>	<b>Groupe de construction</b>	<b>Gruppo di costruzione</b>	<b>Montagegroep</b>	<b>Grupo de construccion</b>
1	Pump oil Suntec ATE2V55D	Pompe # fioul Suntec ATE2V55D	Pompa gasolio Suntec ATE2V55D	Oliepomp Suntec ATE2V55D	Bomba de gasóleo Suntec ATE2V55D
2	solenoid coil Suntec 220-240V/50-60Hz	Bobine electrovanne pompe suntec	Bobina magnetica Suntec 220-240V/50-60Hz	magneetspoel Suntec 220-240V/50-60Hz	Bobina magnética Suntec
3	filter oil pump A70 Rev.3 AS 47 (2x)	Filtre Pompe # fioul A70 Rev.3 AS47 (2x)	Filtro Pompa gasolio A70 Rev.3 AS47 (2x)	Filter Oliepomp A70 Rev.3 AS 47 (2x)	Filtro bomba gasóleo A70 Rev.3 AS47 (2x)
4	gasket oil pump ALE 35/55 (2x)	JOINT COUVERCLE POMPE SUNTEC AS 47 (2x)	Guarnizione Pompa gasolio ALE 35/55 (2x)	Pakking Oliepomp ALE 35/55 (2x)	Junta bomba de gasóleo ALE 35/55 (2x)

Übersetzungsliste List of translations		Liste des traductions Traduzione delle descrizioni		Vertalinglijst Lista de traducciones	
Pos	Description	Denomination	Descrizione	Benaming	Descripción
5	Hose set cpl yellow	Jeu de tuyau jaune	Tubetto giallo	Slangenset geel	Conjunto de tubo flexible amarillo
6	Washer 13x18x1,5 (5x)	Joint 13x18x1,5 (5x)	Guarnizione 13x18x1,5 (5x)	Dichting 18 x 13 x 1,5 (5x)	Junta toma presiones mirilla 13x18x1,5
7	Screw connection 3/8x1/4" straight	RACCORD 3/8"X1/4",DROIT	Raccordo 3/8x1/4"	Nippel 3/8"x1/4" recht vr olieflexibel	Racor 3/8 x 1/4
8	Motor 50W 230V 50Hz SP	Moteur 50W 230V 50Hz	Motore 50W 230V 50Hz	Motor 50W 230V 50Hz	Motor 50W 230V 50Hz
9	Clutch white (2x)	Accoupl mot.- pompe fioul 2 meplats(2x)	Accoppiamento bianco (2x)	Koppeling wit (2x)	Acoplamiento blanco (2x)
10	Capacitor 3µF	Condensateur 3âf moteur hg 90w	Condensatore 3MF	Condensator 3MF	Condensador 3MF 400V Mot AEG
11	Ignition Danfoss EBI V4 spare part	Transformateur allumage ebi danfoss v4	Dispositivo di accensione Danfoss EBI V4	Ontstekingsunit Danfoss EBI V4	Transformador de encendido EBI V4
12	Distribution cylinder BZ	Cylindre de distribution BZ	Cilindro di distribuzione BZ	Verdeelcilinder BZ	Cilindro de distribución BZ
<b>8C</b>	<b>Element of construction</b>	<b>Groupe de construction</b>	<b>Gruppo di costruzione</b>	<b>Montagegroep</b>	<b>Grupo de construccion</b>
1	Screw connection XGE 4LLR 1/8" cyl.	RACC DROIT VIS XGE 4 LLR 1/8"	Raccordo XGE 4LLR 1/8"	Nippel XGE4LLR 1/8" voor oliepompe	Unión roscada XGE 4LLR 1/8
2	Oil pipe BZ	Conduite fioul BZ	Tubazione del gasolio BZ	Olieleiding BZ	Tubería de gasóleo BZ
3	Preheater oil FPHB5-LE PTC70 B10 BZ	Réchauffeur de fioul FPHB5-LE PTC70 B10	Preriscaldatore del gasolio FPHB5-LE PTC	Olievoorverwarmer FPHB5-LE PTC70 B10 BZ	Pre calentador de gasóleo FPHB5-LE PTC70
4	Cut-off valve LE6 sp	Clapet retenu le6	Valvola a membrana LE6	Membraanventiel LE6 voor Unit BE	Válvula antigoteo LE6
5	UV-flaming sensor QRC SAFE BZ/BE_3	Detect flam qrc safe BZ/BE	UV-flaming sensor QRC SAFE BZ/BE_3	Fotocel QRC SAFE voor brander BE_3/BZ	Fotocélula QRC SAFE BE_3
6	Pressure test nozzle R 1/8" MS	BUSE MESURE R 1/8	Nipplo di prova pressione R1/8" Ms	Meetnippel gasstraat R 1/8	Toma presiones R 1/8" MS
7	Mounting holder QRC HT	Support QRC HT	Supporto QRC HT	Haakse fotocelhouder QRC HT	Soporte QRC HT
8	Ignition strand + BZ 1.0 2pc V2	CABLE ALLUM BZ 1.0 (2x) V2	Cavetto accensione BZ 1.0 (2x) V2	Hoogspanningsleiding BZ 1.0 (2x) V2	Cable de encendido BZ 1.0 (2x) V2
9	Grommet BZ 1.0	Passe fill BZ 1.0	Passacavo BZ 1.0	Doorvoertule BZ 1.0	Prensa cable BZ 1.0
10	Seal D28x22x3	Joint D28x22x3	Guarnizione D28x22x3	Afdichting D28x22x3	Junta D28x22x3
12	Nozzle oil 0.45gph 60gr HR Danfoss everp	gicleur fioul 0.45gph 60gr HR Danfoss	ugello per gasolio 0.45gph 60gr HR Danfo	olie-inspuitter 0.45gph 60gr HR Danfoss	tobera de gasóleo 0.45gph 60gr HR Danfos
12	Oil nozzle 0,35gph 80Gr HR	Gicleur 0,35/80° hr	Ugello per gasolio 0,35gph 80Gr HR	Olie-inspuitter 0,35gph 80Gr HR	Tobera de gasóleo 0,35gph 80Gr HR
13	Mixer system BZ 12,0/25,0/5,0/25 VA	Chambre de melange BZ 12,0/25,0/5,0/25VA	Modulo di miscelazioneBZ12,0/25,0/5,0/25	Menginrichting BZ 12,0/25,0/5,0/25 VA	Máquina de mezcla BZ 12,0/25,0/5,0/25 VA
13	Mixer systemBZ 12,1/27,5/5,8/25 VA	Chambre de melange BZ12,1/27,5/5,8/25 VA	Modulo di miscelazioneBZ12,1/27,5/5,8/25	Menginrichting BZ 12,1/27,5/5,8/25 VA	Máquina de mezcla BZ 12,1/27,5/5,8/25 VA
14	Ignition electrode BZ Typ4 L25	ELECTRODE ALLUM BZ L25	Elettrodo accensione BZ Typ4 L25	Ontstekingselektrode type 4 L25 voor BZ	Electrodo de ignición BZ Typ4 L25
14	Ignition electrode BE Type 4 L50 V2	Électrode d'allumage BE Typ4 L50 V2	Elettrodo di accensione BE Typ4 L50 V2	Ontstekingselektrode BE Typ4 L50 V2	Electrodo de encendido BE Tipo 4 L=50
15	Seal D81 V2 everp	JOINT DE TUYERE D81 V2	Dichtung D81 V2	Dichtung D81 V2	Junta D81mm para quemador sist.mezcla V2
16	Blast tube D69/L214 18kW	Tuyere 69/I214 sic 18kw	Raccordo bruciatore D69/L214 SiC 18kW	Branderbuis D69/L214 voor BZ 18kW	Tubo mezclador D69/L214 SiC 18kW
16	Blast tube D83/L214 25kW	Tuyere GB125BE 25kw	Raccordo bruciatore D83/L214 25kW	Branderbuis D83/L214 voor BZ 25kW	Tubo mezclador D83/L214 25kW
17	Support tube L50	TUBE DE SUPPORT L50	Support tube L50	Support tube L50	Tubo Supletorio Ca#ón Cerámico
18	O-ring 92x3	Joint etancheite d 93x3 mm4	O-Ring 92x3 Viton everp	O-Ring 92x3 voor branderbuis Unit BE	Anillo tórico 92x3 Viton
19	Cylinder-head screw DIN7984 M8x25 8.8 A3	VIS A TETE CYLINDRIQUE DIN7984 M8X25 8.8	Cylinder-head screw DIN7984 M8x25 8.8 A3	Cylinder-head screw DIN7984 M8x25 8.8 A3	Tornillo DIN7984 M8x25 8.8 A3K
20	Gasket D130xD106x2 V2	Joint D130x106x2 V2	Guarnizione D130x106x2 V2	Afdichting D130x106x2 V2	Junta D130x106x2 V2

Übersetzungsliste List of translations		Liste des traductions Traduzione delle descrizioni		Vertalinglijst Lista de traducciones	
Pos	Description	Denomination	Descrizione	Benaming	Descripción
21	Pan-head screw DIN7985 M5x10 (5x)	Vis # t#te bombée DIN7985 M5x10 (5x)	Vite a testa bombata DIN7985 M5x10 (5x)	Lenskopschroef DIN7985 M5x10 (5x)	Tornillo DIN7985 M5x10 (5x)
22	Burner flange BZ	Br#leur Trappe de visite BZ	Bruciator Flangia BZ	Brander Aansluitflens BZ	Quemador Brida de conexión BZ
23	Mounting plate oil hose	Plaque de jonction Flexible fioul	Lamierino Tubo gasolio	Vangschaal Oliebuis	Placa de unión Tubo flexible de aceite
24	Gasket D185xD160x3	Joint D185x160x3	Guarnizione D185x160x3	Dichting D185xD160X3 Mengsys. BZ	Junta D185x160x3
25	Screw cyl. DIN7984 M8x16 (5x) V2 packed	vis # t#te cylindrique DIN7984 M8x16 V2	vite cilindrca DIN7984 M8x16 V2 (5x)	cilinderschroef DIN7984 M8x16 V2 (5x)	tornillo de cabeza cilíndrica DIN7984 M8
<b>8D</b>	<b>Element of construction</b>	<b>Groupe de construction</b>	<b>Gruppo di costruzione</b>	<b>Montagegroep</b>	<b>Grupo de construccion</b>
2	Housing Terminal cover SAFe	Couvercle safe GB402	Coperchio SAFe	Behuizing klemmenstrook SAFe	Carcasa cubre conexiones SAFE
3	Control_box SAFe30 V7 DNA SP	SAFe30 V7 DNA	SAFe30 V7 DNA	SAFe30 V7 DNA	SAFe30 V7 DNA SP
4	Housing lower section SAFe	BOITIER ARRIERE SAFE	Involucro Parte inferiore SAFe	Behuizing achterwand SAFe	Carcasa posterior SAFe
5	Connection line 230 V AC Fan	Conduite de raccordement 230V AC Ventil.	Cablaggio di collegamento 230V AC Ventil	Verbindingsleiding 230V AC Ventilator	Tubo de conexión 230V AC Ventilador
6	Connecting pipe air	Conduite de raccordement	Tubazione di collegamento	Verbindingsleiding	Tubo de conexión
7	Ignition cable SAFe 230 V	Cable allumage - safe	Cavetto accensione SAFe 230V	Ontstekingskabel SAFe 230V everp	Cable de encendido RE/DE/SE
8	Connection line fuel 1 SAFe	Cable Electrovanne 1 - SAFe	Tubazione di collegamento 1 SAFe	Verbindingsleiding brandstof 1 SAFE	Cable de conexión electroválvula
9	Connection line fuel 2 SAFe	Conduite de raccordement 2 SAFe	Tubazione di collegamento 2 SAFe	Verbindingsleiding brandstof 2 SAFE	Tubo de conexión 2 SAFe
10	Data cable SAFe	Ligne de transmission des données SAFe	Tubazione di collegamento SAFe	Verbindingsleiding Safe MC10 G135	Cable de datos SAFe
11	Con cable sensor SAFe socket	Conduite de raccordement SAFe	Tubazione di collegamento SAFe	Verbindingsleiding SAFe	Tubo de conexión SAFe
12	Gas sensor D29/d6 60mm	Sonde de temperature de fumee 60mm	Sonda gas combusti D29/d6 60 lung.	Rookgasvoeler voor D29/d6 60mm	Sonda de gases para GB125 D29/d6 60mm
13	Sensor Air temperature	Sonde de température	Sensore sicurezza di temperatura	Luchttemperatuurvoeler voor G135	Sensor de temperatura
14	Connection line Fan SAFe	Conduite de raccordement VentilateurSAFe	Cablaggio di collegamentoVentilatoreSAFe	Verbindingsleiding Ventilator Safe	Tubo de conexión Ventilador SAFe
15	UV-flaming sensor QRC SAFe BZ/BE_3	Detect flam qrc safe BZ/BE	UV-flaming sensor QRC SAFe BZ/BE_3	Fotocel QRC SAFe voor brander BE_3/BZ	Fotocélula QRC SAFe BE_3
16	Mains supply cable inlet connector for	Cordon branchement reseau	Cavo di rete	Netaansluitleiding koudetest G135	Cable conexión red SAFe
17	Modul BIM30*-Lol/01 V21-19-JKS sp	module BIM30*-Lol/01 V21-19-JKS	Modulo BIM30*-Lol/01 V21-19-JKS	module BIM30*-Lol/01 V21-19-JKS	módulo BIM30*-Lol/01 V21-19-JKS
17	Modul BIM30*-Lol/01 V21-27-JKS sp	module BIM30*-Lol/01 V21-27-JKS	Modulo BIM30*-Lol/01 V21-27-JKS	module BIM30*-Lol/01 V21-27-JKS	módulo BIM30*-Lol/01 V21-27-JKS
	Adapter H05V-K 0,75 0,8/2,0	Raccord H05V-K 0,75 0,8/2,0	Adattore H05V-K 0,75 0,8/2,0	Adapter H05V-K 0,75 0,8/2,0	Adaptador H05V-K 0,75 0,8/2,0
<b>8E</b>	<b>Element of construction</b>	<b>Groupe de construction</b>	<b>Gruppo di costruzione</b>	<b>Montagegroep</b>	<b>Grupo de construccion</b>
1	Combustion air fan RG130 V4	Ventilateur RG130 V4	Ventilatore RG130 V4	Ventilator RG130 V4	Ventilador RG130 V4
1	Combustion air fan RG 148 V4	Ventilateur RG148 V4	Ventilatore RG148 V4	Ventilator RG148 V4	Ventilador RG148 V4
2	Gasket D133xd91x2	Joint D133x91x2	Guarnizione D133x91x2	Afdichting D133x91x2	Junta D133x91x2
3	Mounting plate air header	Plaque de jonction	Lamierino	Houderplaat	Placa de unión
3	Mounting plate air header RG148	Plaque de jonction	Lamierino	houderplaat	placa de uni###n
4	Cylinder-head screw DIN7984 M8x25 8.8 A3	VIS A TETE CYLINDRIQUE DIN7984 M8X25 8.8	Cylinder-head screw DIN7984 M8x25 8.8 A3	Cylinder-head screw DIN7984 M8x25 8.8 A3	Tornillo DIN7984 M8x25 8.8 A3K
5	Gasket D83/63x36	Joint D83/63x36	Guarnizione D83/63x36	Afdichting D83/63x36	Junta D83/63x36

Übersetzungsliste List of translations		Liste des traductions Traduzione delle descrizioni		Vertalinglijst Lista de traducciones	
Pos	Description	Denomination	Descrizione	Benaming	Descripción
6	Air collector SB105	Collecteur d'air SB105	Collettore d'aria SB105	Luchtaanzuigbuis SB105	Colector de aire SB105
	Case RG130 pac	Capuchon RG130	Tappo RG130	Kapje RG130	Tapa RG130
	Installation material oil burner BE	Matériel de montage Br#leur fioul BE	Materiale per il montaggio Bruciatore a	Montagemateriaal brander BE	Material de montaje quemador de gasóleo
<b>9</b>	<b>Element of construction</b>	<b>Groupe de construction</b>	<b>Gruppo di costruzione</b>	<b>Montagegroep</b>	<b>Grupo de construcción</b>
1	Control_unit MX25	Appareil de régulation MX25	Regolatore MX25	Regeltoestel MX25 S16	Regulador MX25 S16
3	Housing hood white	Carter capot blanc	Copertura involucro bianca	Huis kap wit	Cubierta superior blanca
4	Housing module carrier white	Module plaque de jonction blanc	Modulo Supporto bianco	Module drager wit	Módulo soporte blanco
5	Fuse application 5x20 6,3AT 230V (10x)	Fusible arriere 5x20 6,3AT 230V (10x)	Fusibile posteriore 5x20 6,3AT 230V(10x)	Buissmeltveilig. Achter 5x20 6,3AT 230V	Fusible 5x20 6,3AT 230V (10x)
6	Fuseholder cap	Support de fusible	Porta fusibile	Zekeringhouder	Soporte fusible
7	Connector 3-pole white	Borne de connexion 3- pôles blanc	Morsetto di collegamento 3-bipol. bianco	Aansluitklem 3-polig wit	Connector 3-pole white
8	Connector 3-pol. SF50 pink	Borne de raccordement 3-poles SF50 rose	Morsetto di collegamento 3-pol.SF50 rosa	Aansluitklem 3-polig SF50 roze	Borne de conexión 3-polos SF50 rosa
9	Wire Power HV 1270 Ferrit everp	faisceau de câbles Power HV 1270 Ferrit	Cablaggio Power HV 1270 Ferrit	kabelboom Power HV 1270 Ferrit	mazo de cables Power HV 1270 Ferrit
11	Connector 4-pol 17B18 orange	Borne de raccordeme 4 poles 17B18 orange	Morsetto di collegamento 4-pol. 17B18	Aansluitklem 4-pol. 17B18 oranje	Borne de conexión 4- polos anaranjado
12	Connecting terminal pluggable 3-pol	Borne de connexion 3- pôles jaune	Morsetto di collegamento 3-bipol. giallo	Afsluitklem 3- polig geel	Borne de conexión 3- polos amarillo
13	Connector 4-pole SH I violet	Borne de connexion 4- pôles SH I violet	Morsetto di collegame.4-bipol.SH I viol.	Aansluitklem 4-pol SH I violet	Borne de conexión 4- polos SH I violeta
14	Connector 3-pole PS grey	Borne de connexion 3- pôles ps gris	Morsetto di collegamento 3-pol.PS grigio	Aansluitklem 3-polig PS grijs	Connector 3-pole PS grey
15	Connector 3-pole PZ violett	Connecteur 3 poles violet	Morsetto di collegamento - pol.PZ violett	Aansluitklem 3-polig PZ violet	Connector 3-pole PZ violett
16	Connector 3-pole PH green	Borne de connexion 3- pôles PH vert	Morsetto di collegamento 3-pol. PH verde	Afsluitklem 3-polig PH groen	Connector 3-pole PH green
18	Connector 3-pol. AS red sparepart	Borne de raccordement 3-poles AS rouge	Morsetto di collegamento3-bipol.AS rosso	Aansluitklem 3-polig AS rood	Borne de conexión 3-polos AS rojo
19	Connecting terminal 2-polig WA maygreen	Fiche verte 2 poles wa	Morsetto di collegamento2-bipol WA verde	Afsluitklem 2-polig WA groen	Borne de conexión 2-polos WA verde
20	Connector 2- pin blue	Borne de connexion 2- pol r5 bl everp	Morsetto di collegamento 2-bipolare blu	Aansluitconnector 2-polig blauw	Borne de conexión 2-polos azul
21	Connector 2-pole grey FW	Borne de connexion 2- pôles gris FW	Morsetto di collegame.2-bipol. grigio FW	Afsluitklem 2- polig grijs FW	Borne de conexión 2-polos grey FW
22	Connect. term. 2-polig red	Fiche rouge 2 poles	Morsetto di collegamento2-bipolare rosso	Afsluitklem 2-polig rood	Borne de conexión 2-polos rojo
23	Connector 2- pin orange RC	Borne de connexion 2- pôles orange RC	Morsetto di collegamento2-bip. arancione	Aansluitconnector 2- polig oranje RC	Borne de conexión 2-polos anaranjado RC
24	Connector 2-pole white	Borne de connexion 2-poles blanc	Morsetto di collegamento2-pol bianco	Aansluitklem 2-polig wit	Connector 2-pole white
30	Housing strain relief control (10x)	Décharge de traction (10x)	Fermo antitrazione (10x)	Trekontlasting (10x)	Retenedor de cable (10x)
31	PCB MX25 S15	Circuit imprimé MX25 S15	Scheda elettronica MX25 S15	Printplaat MX25 S15	Placa electrónica MX25 S15
33	Cable harness IP*S01	Faisceau de câbles IP*1 S01	Cablaggio IP*1 S01	Kabelboom IP*1 S01	Mazo de cables IP*1 S01
34	Connecting cable 155mm	Câble 155mm	Cavo 155mm	Kabel 155mm	Cable de conexión 155mm
35	Control element BX25 S03	Élément de commande BX25 S03	Elemento di servizio BX25 S03	Bedieningselement BX25 S03	Módulo de control BX25 S03
36	Housing blind cover BC white	Couvercle BC blanc	Copertura BC	Afdekking BC wit	Recubrimiento BC blanco
37	CW400 Bosch DK	CW400 Bosch DK	CW400 Bosch DK	CW400 Bosch DK	CW400 Bosch DK

**Übersetzungsliste**  
**List of translations**

**Liste des traductions**  
**Traduzione delle descrizioni**

**Vertalinglijst**  
**Lista de traducciones**

Pos	Description	Denomination	Descrizione	Benaming	Descripción
37	CW400 Bosch DE,AT,LU	CW400 Bosch DE,AT,LU	CW400 Bosch DE,AT,LU	CW400 Bosch DE,AT,LU	CW400 Bosch DE,AT,LU
37	CW400 Bosch CH,BE,IT	CW400 Bosch CH,BE,IT	CW400 Bosch CH,BE,IT	CW400 Bosch CH,BE,IT	CW400 Bosch CH,BE,IT
38	Casing flap MX25	Boîtier couvercle MX25	Involucro copertura di protezione MX25	Behuizing afdekking MX25	Carcasa couvercle MX25
40	Outside temperature sensor	Sonde de température extérieure	Sonda esterna	Buitentemperatuurvoeler	Sensor de temperatura exterior
41	Temperature sensor NTC RD 6,0 12K 6000mm	Kit capteurs NTC RD 6,0 12K 6000 emballé	Sonda di temperatura NTC RD 6,0 12K 6000	Temperature Sensor 6x40,6000mm	Sensor temperatura NTC RD 6,0 12K 6000mm
50	Connect-Key	Clé de connexion K30 RF	Chiave di collegamento	Bosch Connect-Key K 30	Connect-Key
51	Key wallsocket & cable set	Support mural set	Supporto a parete set	Muurbeugel set	Soporte de pared set
52	Basic kit connect key	Set de base du module sans fil	Set base connessione modulo wireless	Basis wireless module	Módulo conexión adaptado inalámbrico
	LAN-Cable RJ45 Cat.5 2000	LAN-câble 2000	LAN-Cavo 2000	LAN-kabel 2000	LAN-cables 2000

Gerätetypen Types of appliances	Types de chaudières Tipo apparecchi	Toesteltypes Tipos de aplicaciones	Bemerkungen Remarks Remarques Osservazioni Opmerkingen Observaciones
Gerät Appliance Chaudière Apparecchio Toestel Aparato	Bestell-Nr. Ordering no. Numéro de commande N° d'ordine Bestelnummer Número el ordenar	Land Country Pays Paese Land Paese	
OC8000F 19	7 736 602 437	Belgien, Deutschland, Schweiz, Österreich	
OC8000F 27	7 736 602 438	Belgien, Deutschland, Schweiz, Österreich	
OC8000F 19	7 736 603 782	Dänemark	
OC8000F 27	7 736 603 783	Dänemark	



**BOSCH**

Bosch Thermotechnik GmbH  
Junkersstr. 20-24  
D-73249 Wernau / Germany